

INTRODUCTION

1. GENERAL

This documentation provides the information necessary to operate, maintain and service all versions of the PRO 36 Studio Tape Recorder.

The PRO 36 is a professional installation for broadcasting and television studios, theatres, sound and film production and recording studios.

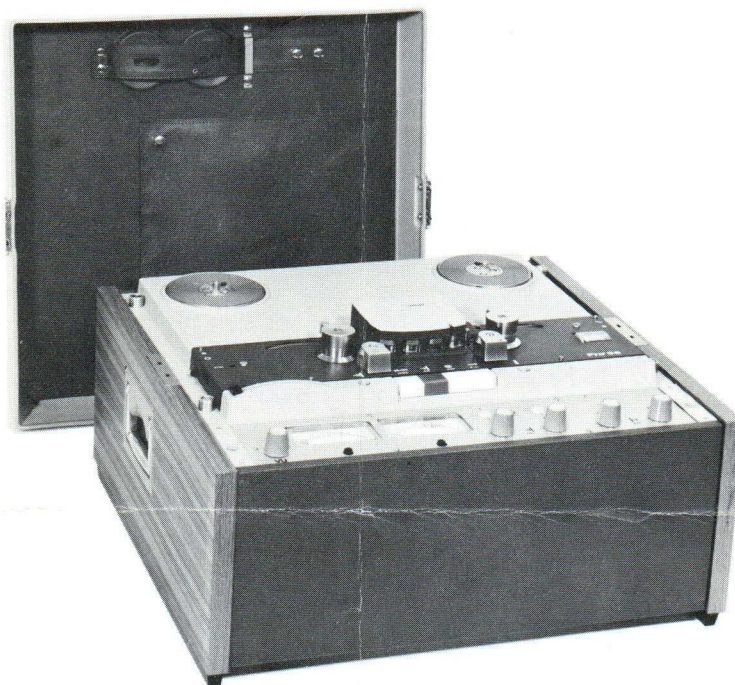

Fig. I-1

2. BRIEF DESCRIPTION

The PRO 36 is a mains driven, self-contained unit utilizing $\frac{1}{4}$ -inch tape. It accepts 300-mm DIN compatible plates, $10\frac{1}{2}$ inch NAB reels, and up to 7-inch Ciné reels by means of interchangeable reel adapters. It can be supplied as:

- a portable recorder
- a console type
- an unmounted version for fitting into a desk or 19-inch standard rack.

All three versions can be supplied with a choice of up to five different track configurations.

- mono full track
- mono half track
- stereo
- twin-track (split erase head)
- mono + pilot track

As there are also a number of optional extras and accessories available (see chapter 5), it can be seen that a recorder can be supplied for every requirement in its specific operating field.

The PRO 36 comprises three main parts:

- the tape deck (including power supply and bias and erase oscillator(s)).
- a plug-in head assembly with playback pre-amplifier(s).
- an amplifier unit with record and playback electronics.

2.1 TAPE DECK

The tape deck consists of a single chassis with provision for mounting sub-units and positioning the plug-in head assembly. Three a. c. motors are used; one as a capstan motor and the other two as torque motors for wind and rewind actions.

The tape drive is servo controlled and locks the selected speed to the mains frequency or to an external reference source. The use of d. c. energized eddy current braking results in a constant and hunting-free tape speed. All three speeds of 15, $7\frac{1}{2}$ and $3\frac{3}{4}$ ips can be electronically switched.

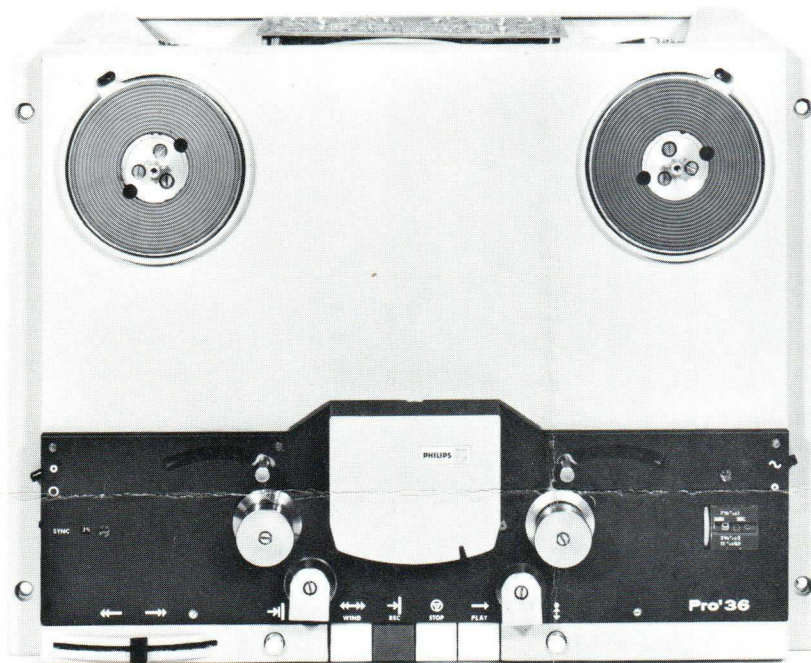

Fig. I-2

The speed and direction of the winding motors are controlled by a thyristor circuit, the speed being variable via this circuit with the aid of a lever.

Other sub-units of the tape deck are:

- mains switch
- reel selector switch
- speed selector switch
- operator's controls
- pinch roller and cue facility
- a guide roller (left) and counter roller (right)
- a time counter (with reset facility) driven by the counter roller
- two damped lever to prevent looping and to operate the tape break indicators
- solenoid operated brakes
- a "SYNC." lamp
- a "MAINS" lamp
- plug-in bias and erase p. c. boards
- plug-in drive oscillator

- preset bias controls for each speed of each track (six in all)
- standard wiring suitable for all versions

To avoid unnecessary wear, the tape is automatically lifted from all heads during fast wind and when stopped. For cueing, the tape can be brought into contact with the playback head during fast wind.

All preset controls are automatically selected when the tape speed is changed, permitting optimum bias current adjustment for each speed.

2.2 HEAD ASSEMBLY

The headblock has three reference surfaces to ensure correct positioning. The head assembly has four heads (erase, recording and playback and a dummy).

The dummy can be replaced by a pilot tone head for synchronization with film or perforated tape. Individual heads are mounted in Mu-metal screens.

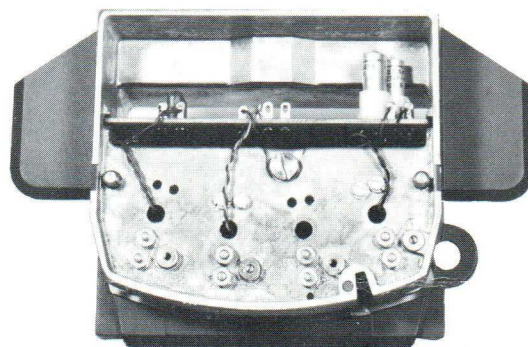

Fig. I-3

The head assembly houses one p. c. board with one (mono) or two (stereo) pre-amplifiers. The head assembly of the pilot version also accommodates an additional p. c. board with the pilot amplifier.

2.3 AMPLIFIER UNIT

The amplifier unit consists of a metal housing with a front panel and contains the plug-in p. c. boards which comprise the electronics.

The unit can be mounted in front of the tape deck (portable and console version see Fig. I-1 and front photo) or underneath the tape deck (console versions without operating panel). It is connected to the deck via a multicore cable and connector. The unit is standard wired for two channels and also allows direct line-to-amplifier connection.

The front panel can be equipped with VU-meter(s) and level controls or, at choice, be supplied as a panel with holes for access to the screwdriver operated controls. Also at choice, a microphone pre-amplifier can be supplied for each channel.

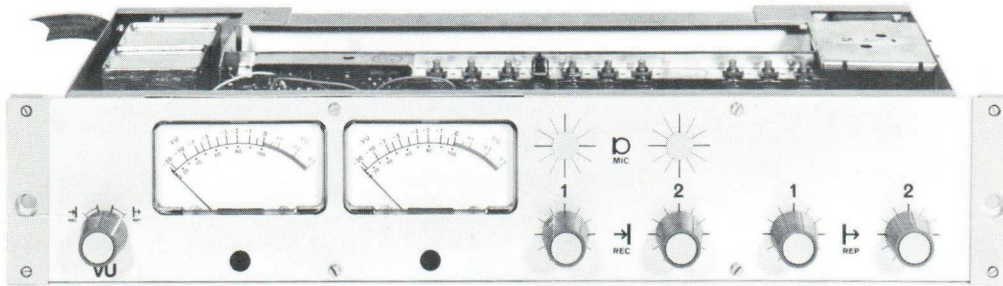

Fig. I-4

In the case of mono full track with pilot tone configuration, pilot tone record and reproduce switches are provided together with lamp indicators.

In the case of two track with selective erasure configuration, two push-button track selector switches with pilot lamp indication are supplied.

The playback and recording amplifiers both have preset controls for treble and equalization networks. The recording amplifier also has preset controls for modulation.

These controls and a network for each tape speed are electronically selected via the speed selector. At the amplifier board the equalization can be switched to IEC or NAB standard.

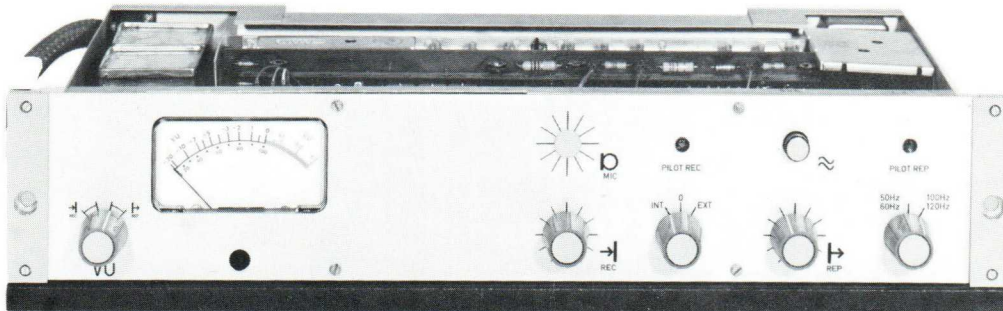

Fig. I-5

3. TECHNICAL DATA

GENERAL

Tape speeds	: 15, 7½ and 3¾ ips ± 0.2 %				
Tape width	: ¼ inch				
Reel type	: NAB, DIN, Ciné (dia 7...12 inches)				
Tape slip (matted backing)	: 0.2 %				
Tape tension	: 60...125 g (for 1000 m tape)				
Starting time	: max. 1 sec. for reaching a flutter figure of 0.1 % peak value weighted				
Heads	: max. 4; FXC type				
Track width	: mono: 6.25 mm				
	: stereo: 2 x 2.75 mm				
	: two-track: 2 x 2.20 mm				
	: pilot-track (neo-pilot): 2 x 0.45 mm				
Mains frequency	: 50 Hz and 60 Hz				
Mains voltage	: 110, 117, 127, 220, 245 V ± 10 %				
Power consumption	: 250 VA				
Ambient temperature	: 5...45 °C				
Dimensions and weight		Height	Width	Depth	Weight
	Portable	22 cm	52 cm	48 cm	40 kg
	Console	80 or			
		90 cm	62 cm	57 cm	61 kg
	Chassis	19 cm	48.5 cm	44.5 cm	38 kg

ELECTRICAL

Erase current	: 70...100 mA (adj.)			
Bias current	: max. 10 mA			
Bias frequency	: 95 kHz ± 1 kHz			
Phase error (between stereo tracks)				
at 10 kHz	15 ips	45°		
	7½ ips	60°		
	3¾ ips	90°		
Crosstalk (at 1000 Hz)		15 ips	7½ ips	3¾ ips
	Stereo	42 dB	42 dB	42 dB
	Two-track	60 dB	60 dB	60 dB
Microphone input (symm.; free from earth)	: Input impedance: ≥ 1000 Ω			
	: Source impedance: 200 Ω (adaptable for 50 Ω)			
	: Min. input level: 0.5 mV			
Line input (symm.; free from earth)	: Input impedance: ≥ 10 kΩ			
	: Source impedance: 200...600 Ω			
	: Nominal input level: +6 dBm			
	: Minimum input level: -14 dBm			
Line output (symm.; free from earth)	: Output impedance: ≤ 50 Ω			
	: Load impedance: 600 Ω (adaptable for 200 Ω)			
	: Nominal output level: +6 dBm			
	: Max. output level: +18 dBm			

I. E. C.

Equalisation:

15 ips	7½ ips	3¾ ips
35 µsec.	70 µsec.	90+3180 µsec.

Frequency response:

15 ips	63...12000 Hz (+ 1 dB)
	40...18000 Hz (+ 2 dB)
7½ ips	63...10000 Hz (+ 1 dB)
	40...15000 Hz (+ 2 dB)
3¾ ips	63... 8000 Hz (+ 1 dB)
	40...12000 Hz (+ 2 dB)

Wow and flutter:

Measured with EMT 420; weighted
DIN 45507; peak value

	weighted	unweighted
15 ips	≤ 0.04 %	≤ 0.1 %
7½ ips	≤ 0.06 %	≤ 0.15 %
3¾ ips	≤ 0.10 %	≤ 0.2 %

Distorsion (including tape distorsion):

	15 ips	Modulation
Mono	1 %	32 mM/mm
Stereo	1.5 %	51 mM/mm
Measured with AGFA PER 525		

	7½ ips	Modulation
Mono	1 %	32 mM/mm
Stereo	1.5 %	51 mM/mm
Measured with AGFA PER 525		

	3¾ ips	Modulation
Mono	1 %	25 mM/mm
Stereo	1 %	25 mM/mm
Measured with BASF LP26		

Signal-to-noise ratio (overall)

Fulltrack

speed	weighted	unweighted
15 ips	61 dB	61 dB (ref. to 32 mM/mm)
7½ ips	58 dB	60 dB (ref. to 32 mM/mm)
3¾ ips	58 dB	58 dB (ref. to 25 mM/mm)

N. A. B.

Equalisation:

15 ips	50+3180 µsec.
7½ ips	50+3180 µsec.
3¾ ips	90+3180 µsec.

Frequency response)

15 ips	40...15000 Hz
7½ ips	30...15000 Hz
3¾ ips	50...10000 Hz

) Tolerances acc. N.A.B. recommendations.

Wow and flutter:

Measured with MICOM; R. M. S. value

	weighted	unweighted
15 ips	≤ 0.04 %	≤ 0.1 %
7½ ips	≤ 0.06 %	≤ 0.15 %
3¾ ips	≤ 0.10 %	≤ 0.2 %

Measured with flutter tape on N. A. B. reel

Distorsion (playback):

0.3 %

Distorsion (including tape distorsion) at
operational level (-7 dB with respect to peak
record level)

	Mono	Stereo
15 ips	1 %	1 %
7½ ips	1.5 %	1.5 %
3¾ ips	1.5 %	1.5 %

Signal-to-noise ratio (overall, ref. to peak

record level)

Fulltrack

speed	weighted	unweighted
15 ips	68 dB	67 dB
7½ ips	68 dB	66 dB
3¾ ips	63 dB	63 dB

Stereo			Stereo		
speed	weighted	unweighted	speed	weighted	unweighted
15 ips	61 dB	61 dB (ref. to 51 mM/mm)	15 ips	64 dB	64 dB
7½ ips	58 dB	60 dB (ref. to 51 mM/mm)	7½ ips	62 dB	62 dB
3¾ ips	54 dB	54 dB (ref. to 25 mM/mm)	3¾ ips	59 dB	59 dB

Note: 15 ips and 7½ ips measured with Scotch 206
3¾ ips measured with Scotch 207.

Note: 15 ips and 7½ ips measured with
AGFA PER 525
3¾ ips measured with BASF PES 26

4. VERSIONS

The chart of Fig. I-5 gives details and Philips identity/ordering codes for all versions of the PRO 36.

In order to illustrate the way of obtaining the identity of a particular version, the example below is taken.

- a. Mono full-track, 50 Hz
- b. With VU-meter
- c. Without microphone amplifier
- d. In console 80 cm high
- e. Amplifier in front of tape deck

Take the following steps

1. Find the column with the heading "CONSOLE 80 cm (32") ampl. front".
2. Select in this column, "MONO full track".
3. Select row "50 Hz".
4. Select in this row "METERS".
5. Further select "NO MICR. CH."

The intersection of the row found in 6 with the column found in 3, gives the missing digits, (503).

Thus the full number is: 8920 005 50301

The letters in the square just found, indicate the units of this version.

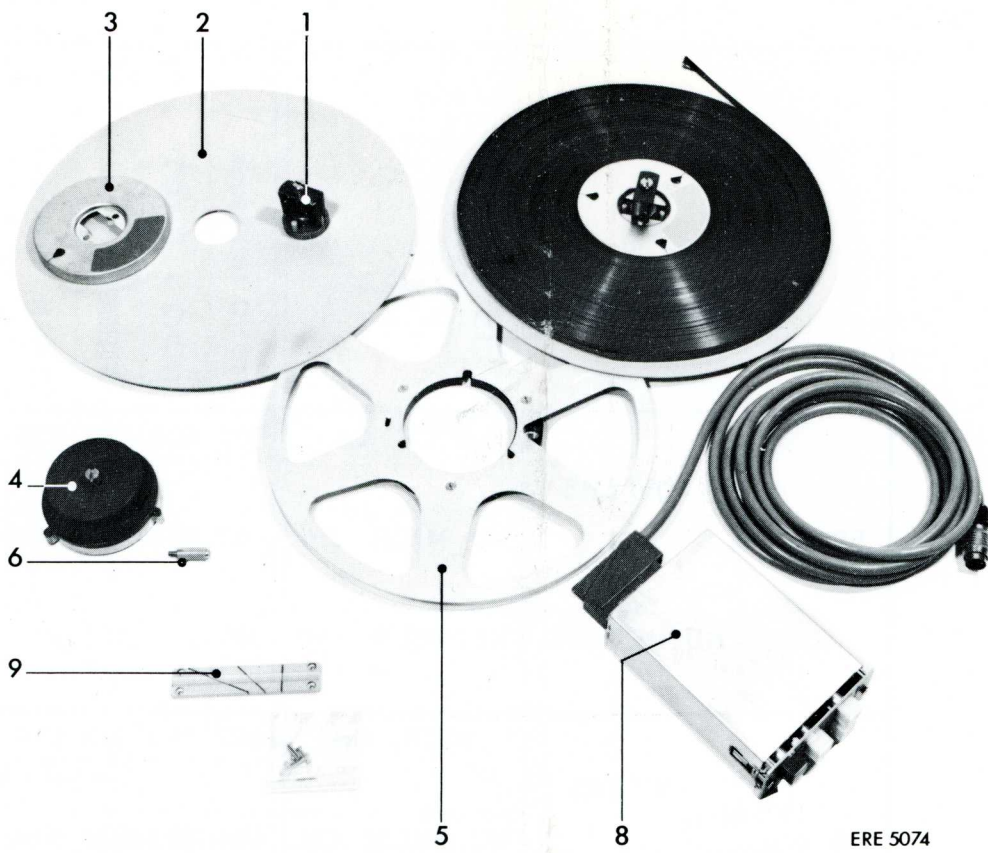

ERE 5074

Fig. I-7

5. ACCESSORIES

The accessories available are listed below together with their indentities

1	8920 238 90011	CCIR adaptor
2	8920 015 40101	CCIR supporting plate
3	8990 211 06019	Empty CCIR core 100 mm
	8990 211 16519	CCIR core with 1000 m, $\frac{1}{4}$ inch standard tape
4	8990 238 90021	NAB adaptor
5	8990 211 00019	Empty NAB reel, $10\frac{1}{2}$ inch
	8990 211 10519	NAB reel $10\frac{1}{2}$ inch with 2400 ft standard tape
6	8990 238 90039	Ciné adaptor
	8920 040 10401	Set of four wheels
8	8920 015 90101	Remote control unit
9	8920 015 80101	Tape splicing jig
	8993 993 07001	Hand demagnetiser
	8920 016 00101	Synchronisation unit for pilot tone version PRO 36
	5322 344 40041	Hours of use counter
	8920 030 00701	Microphone pre-amplifier

6. HEADS

8920 045 00001	Full track erase head
8920 045 02101	Two track erase head
8920 045 10001	Full track recording head
8920 045 11001	Half track recording head
8920 045 12001	Two track recording head
8920 045 15001	Stereo recording head
8920 045 20001	Full track playback head
8920 045 21001	Half track playback head
8920 045 22001	Two track playback head
8920 045 25001	Stereo playback head
8920 045 30101	Dummy head
8920 045 42001	Pilot recording/playback head

7. SEPARATE UNITS

8920 030 00701	Microphone amplifier, with pot. meter, plug and mounting cable
8920 030 00901	HF, oscillator unit
8920 030 01001	HF, driver oscillator unit
8920 030 00801	Recording/playback amplifier board
8920 030 01101	Pilot tone recording/playback amplifier board
8920 040 10101	Set of columns 90 cm
8920 040 10201	Set of columns 80 cm
8920 040 10301	Console housing
8920 040 10501	Wooden case
8920 040 10601	19" rack mounting set

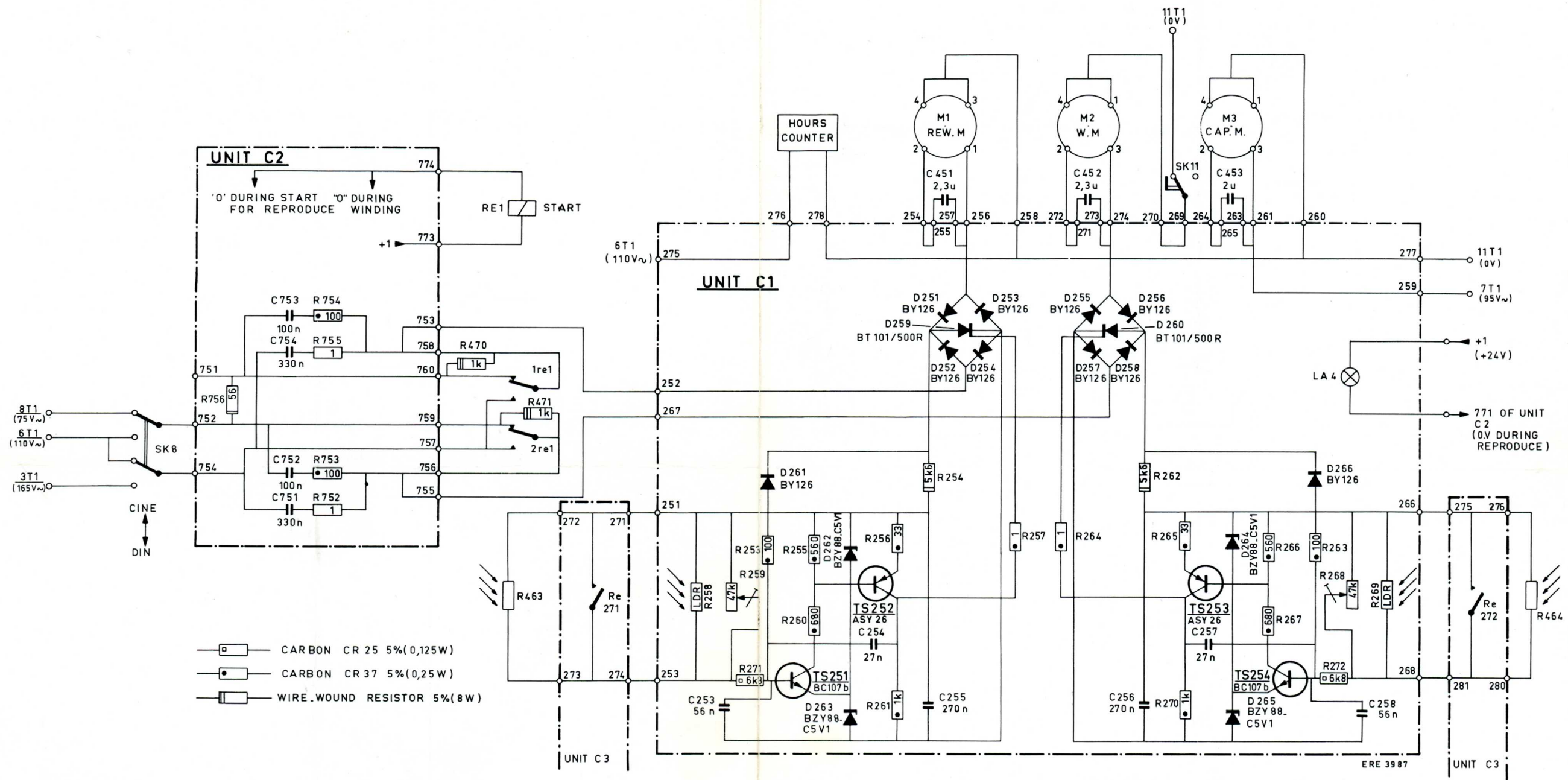
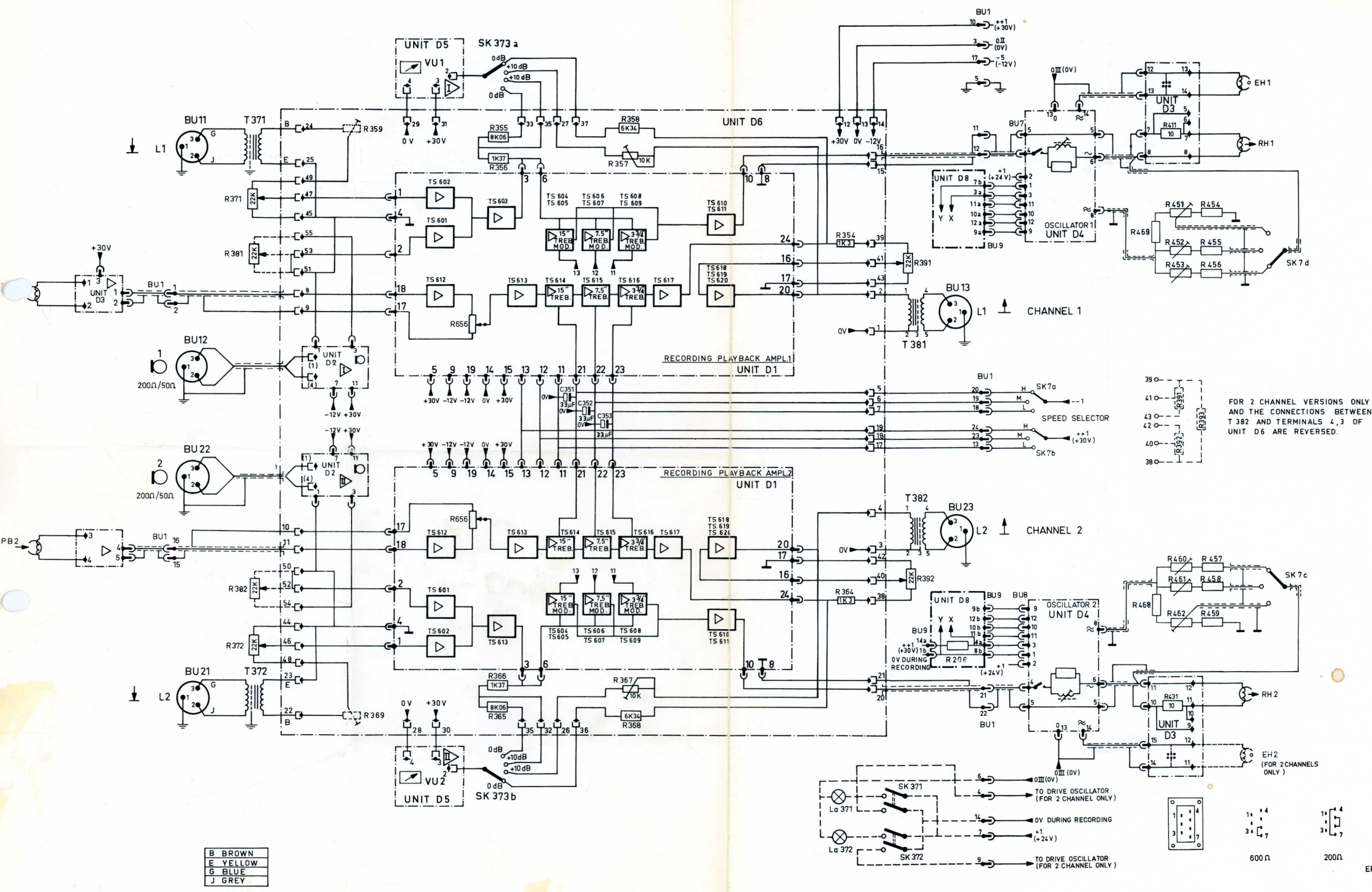

Fig. IV-9



B	BROWN
E	YELLOW
G	BLUE
J	GREY

FOR 2 CHANNEL VERSIONS ONLY
AND THE CONNECTIONS BETWEEN
T 382 AND TERMINALS 4, 3 OF
UNIT D6 ARE REVERSED.

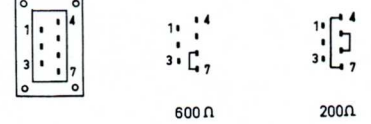

Fig. IV-13

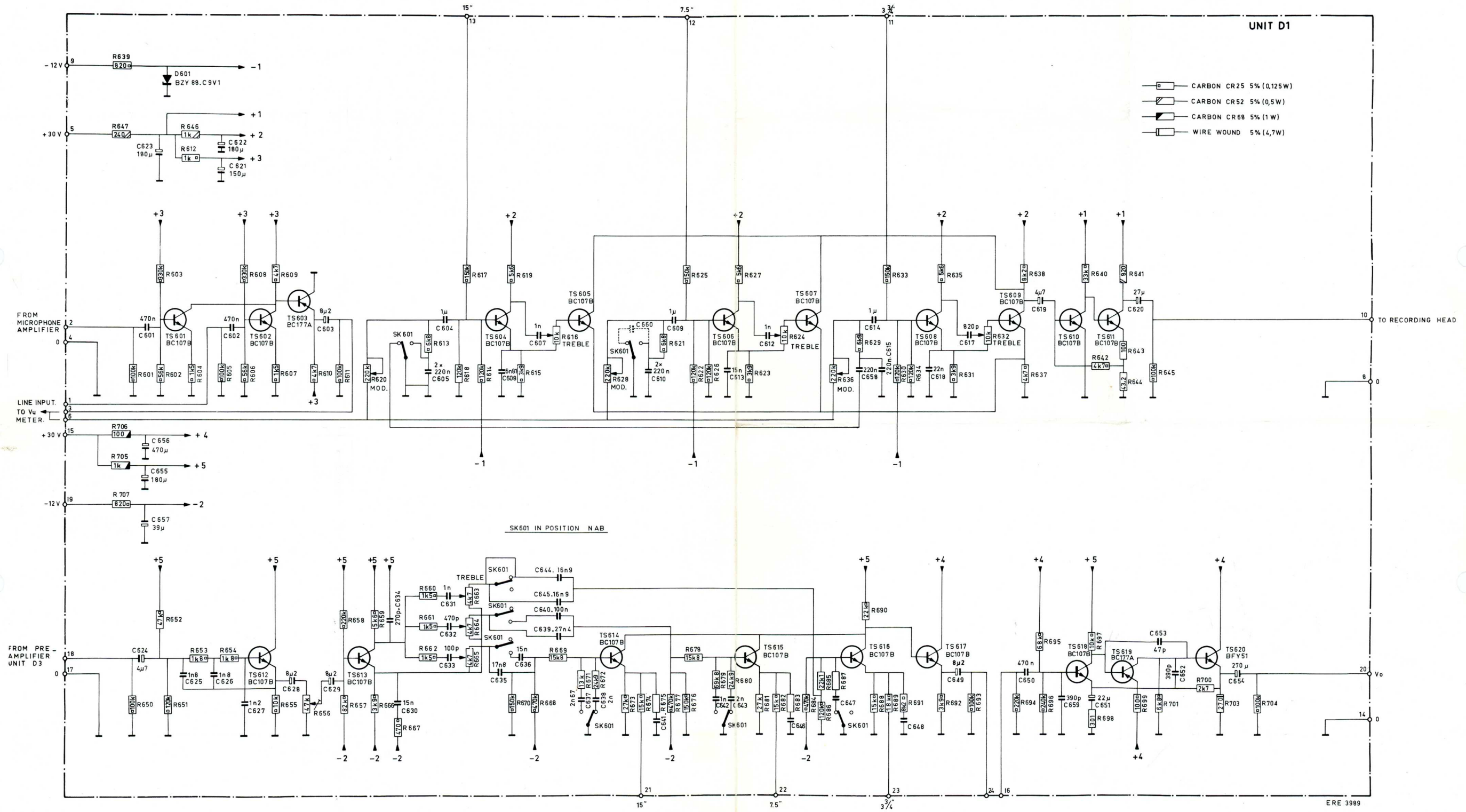

Fig. IV-17

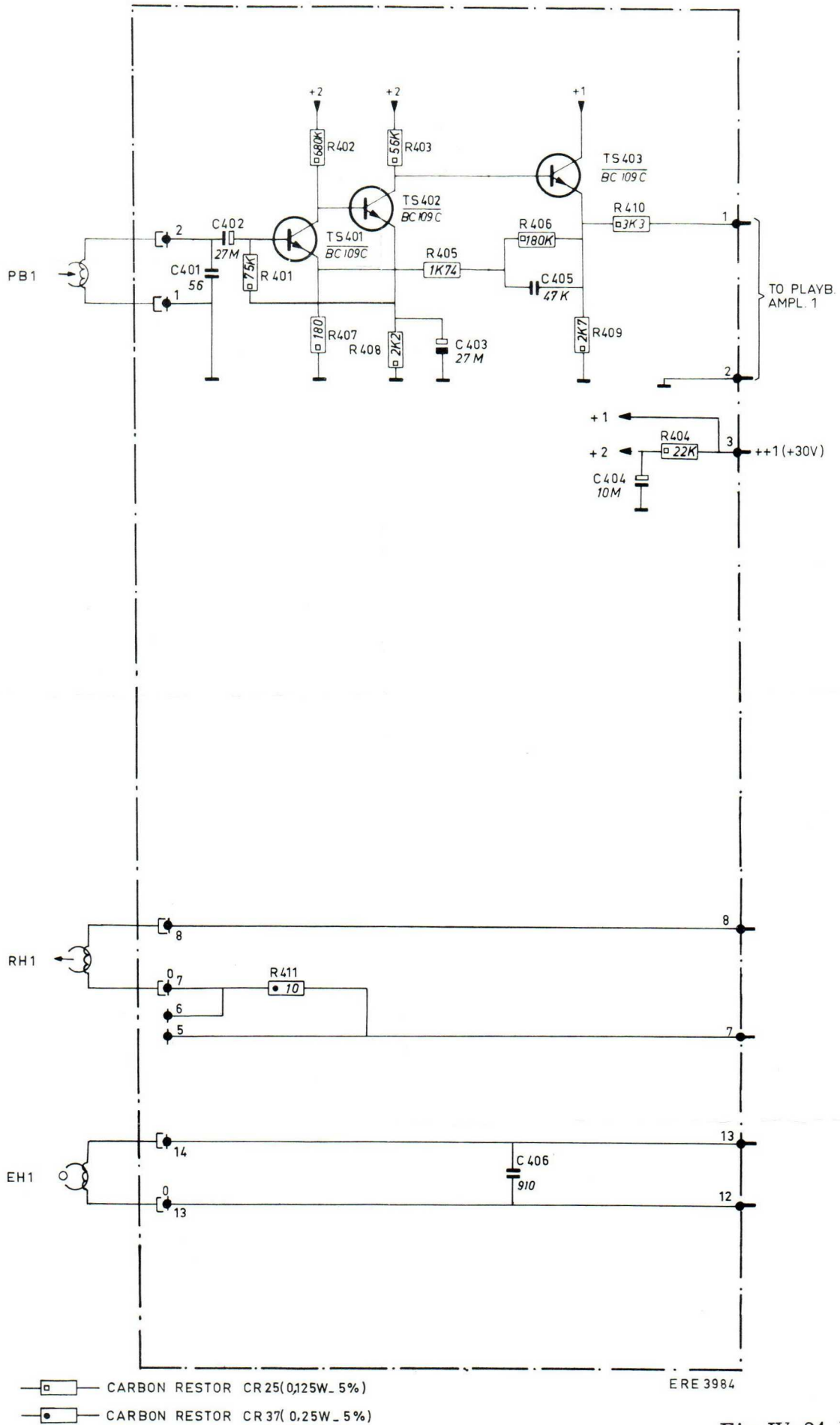

Fig. IV-24 MONO

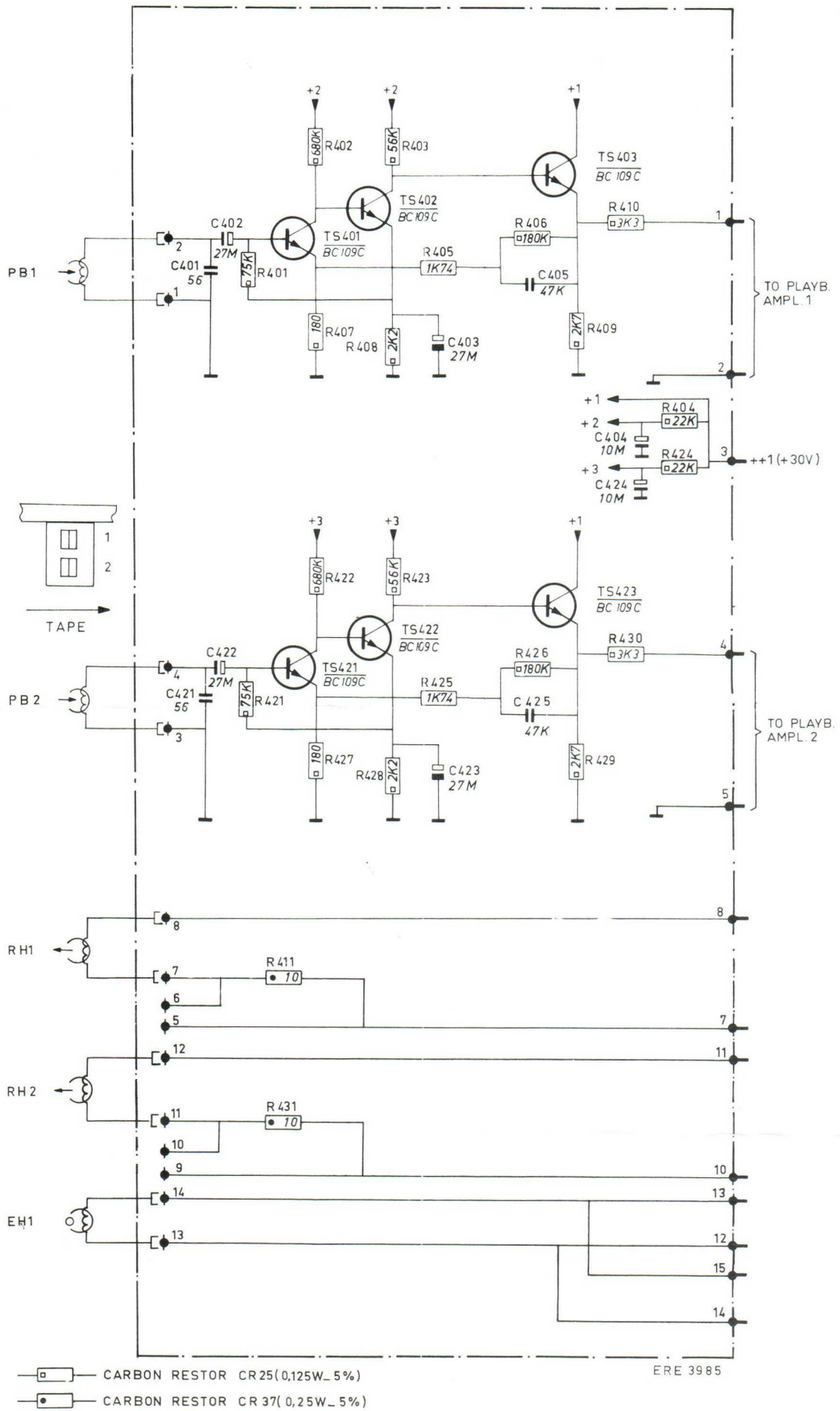

Fig. IV-25 STEREO

5. SPARE PARTS LIST UNIT D4

Item	Description	Code number
L201	Coil	5322 158 20334
L202	Coil	5322 158 50044
C201	Capacitor 100 μ F, 40 V	5322 124 20337
C202	Capacitor 10 K , 250 V	5322 121 40088
C203	Capacitor 1K8	5322 120 64194
C204	Var. capacitor 52-385 pF	4822 125 20154
C205	Capacitor 2K7	5322 120 64118
C206	Capacitor 390 pF	5322 120 64096
C207	Capacitor 3K3 , 125 V	5322 123 10235
RE201	Relay	5322 280 70138
BC107b	Transistor	5322 130 40332
BAX12	Diode	5322 130 30424
OA95	Diode	5322 130 30191

niet

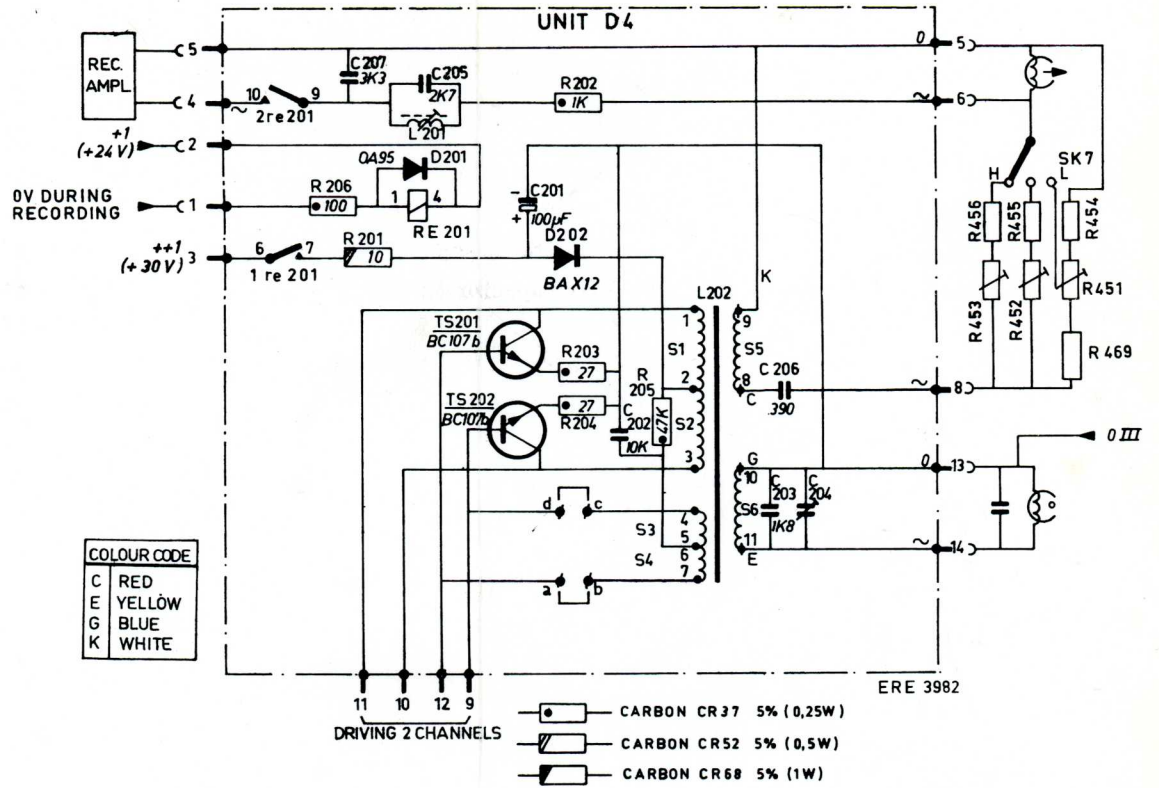

Fig. IV-30

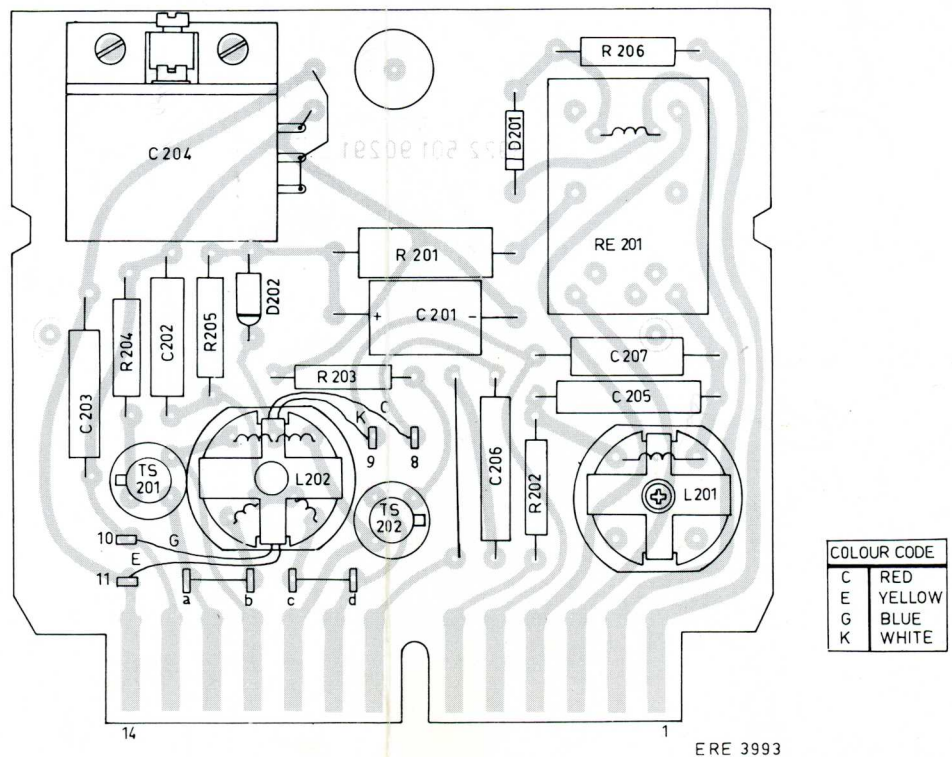

Fig. IV-31

Unit D7

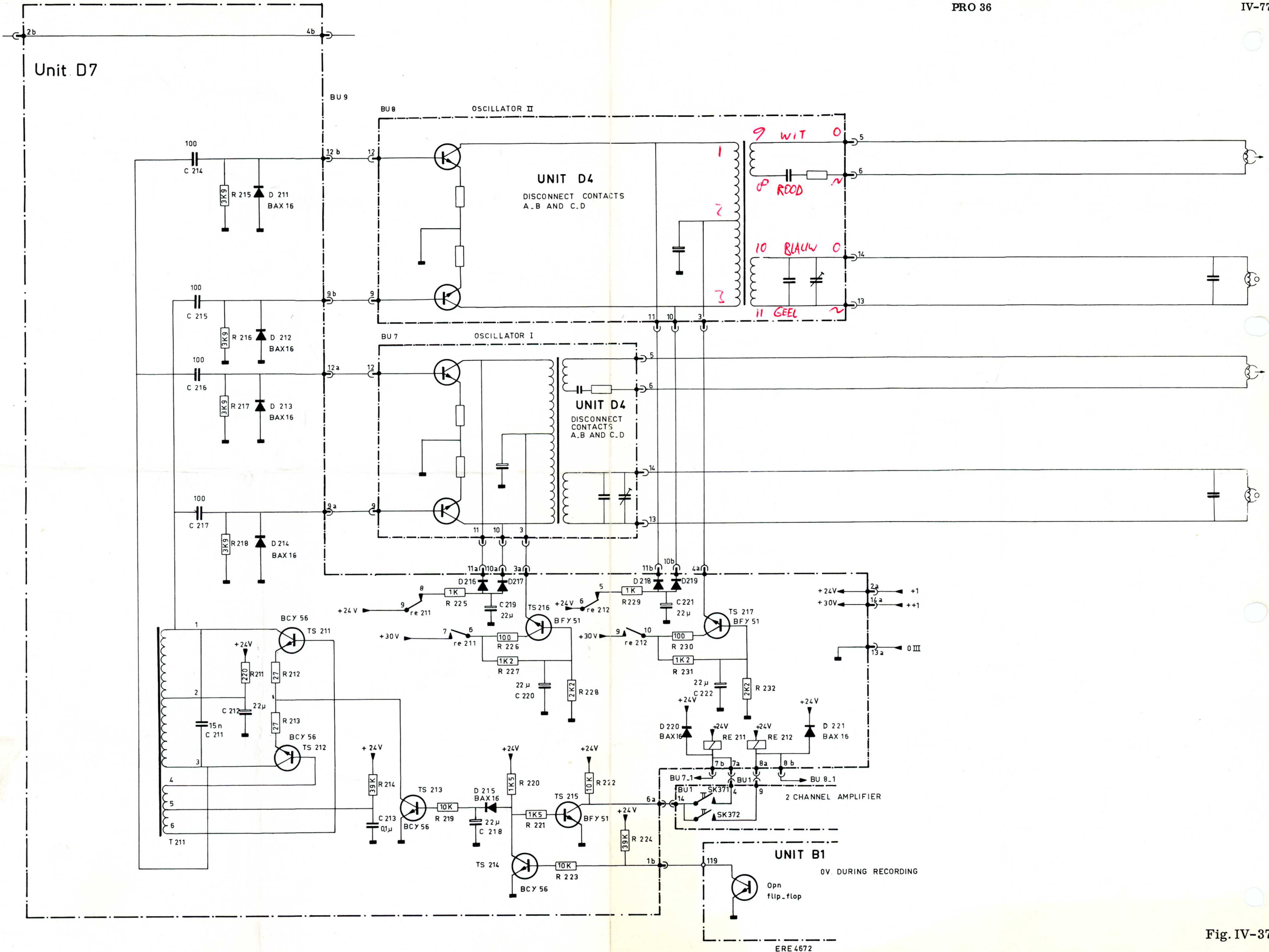

Fig. IV-37

ERE 4672

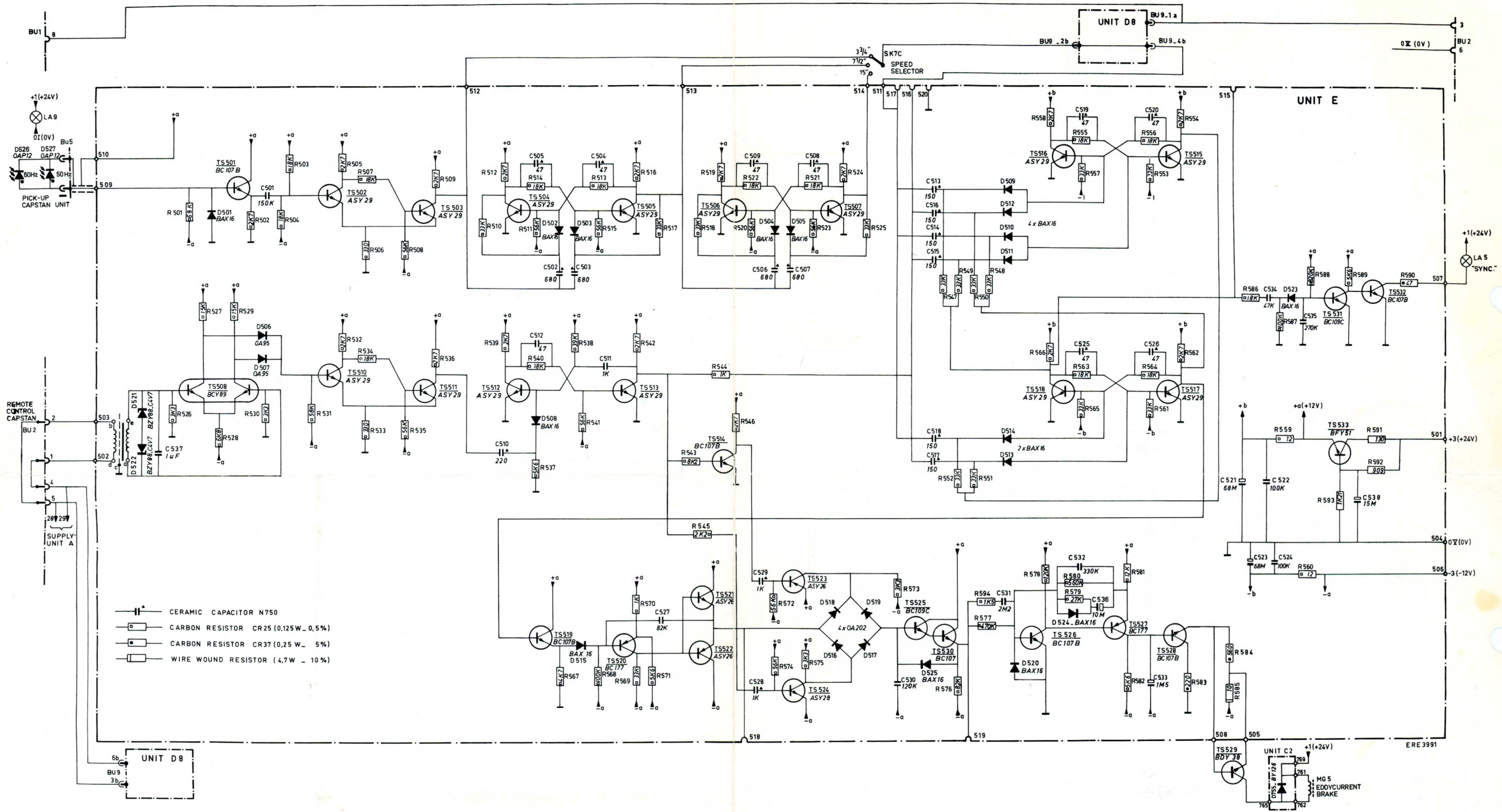

Fig. IV-43