

POWER GRID TUBES

FOR RADIOBROADCASTING TRANSMITTERS

DTE 115

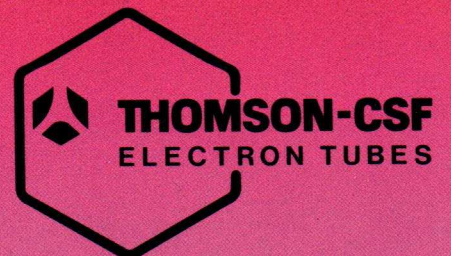



CONTENTS

FOREWORD	3
PART ONE	3
	Page
I - TECHNICAL INFORMATION	3
I.1 - Introduction	3
I.2 - Triodes	4
I.3 - Tetrodes	5
II - USE OF TUBES IN RADIOBROADCASTING	6
II.1 - Characteristics of High Power Transmitters	6
II.2 - Comparative Table Triodes/Tetrodes	6
II.3 - Factors Influencing the Choice of a Power Grid Tube	7
III - TECHNOLOGY	8
III.1 - Thoriated-Tungsten Cathodes	8
III.2 - Grids	8
III.3 - Anodes	10
III.4 - Ceramic Insulators	12
IV - CONNECTORS	13
V - OPERATING INFORMATION AND RECOMMENDATIONS	14
V.1 - Cathodes and Temperature	14
V.2 - Grids	15
V.3 - Anodes	16
V.4 - Applying Tube Voltages	16
V.5 - Cooling	16
VI - MAINTENANCE	18
VI.1 - Systematic and Periodic Testing	18
VI.2 - Replacing a Tube	18
VII - TRANSPORTATION - HANDLING - STORAGE	19
VII.1 - Receiving the Tube	19
VII.2 - Storage	19
VII.3 - First Use	19
PART TWO	21
INFORMATION, DEFINITIONS	23
MEASUREMENT CONDITIONS	23
TUBE TECHNICAL DATA	26
TUBE DIMENSIONS TABLE	63

THOMSON-CSF ELECTRON TUBE DIVISION 1986

Information supplied by Thomson-CSF is believed to be accurate and reliable. However, no responsibility is assumed by Thomson-CSF for its use nor for any infringements of patents or other rights of third parties which may result from its use. No license is granted by implication or otherwise under any patent rights of Thomson-CSF. Any copy, reproduction or translation of this information, either wholly or in part, without the express written agreement of Thomson-CSF Electron Tube Division is expressly forbidden under the French law of 11 March, 1957.

FOREWORD

The history of power grid tubes has always been closely related to the history of radiobroadcasting.

The Thomson-CSF Electron Tube Division, a pioneer in the field, has contributed to the development of high-performance transmitters, notably by the new technologies employed for its grid tubes such as the Pyrobloc® grids and the Hypervapotron® cooling system.

In spite of the development of semiconductors, the use of grid tubes remains essential. In fact, high power levels at elevated frequencies can be obtained only with the use of power grid tubes.

This catalogue presents the power grid tubes produced for high-power radiobroadcasting transmitters and their main characteristics, allowing the user to choose a tube. For further information, it is necessary to refer to more detailed data sheets available upon request from the Thomson-CSF Electron Tube Division and its international sales network.

The frequency modulation (FM) techniques used in FM radiobroadcasting are similar to those used in television. Therefore, the triodes and tetrodes applied in FM radiobroadcasting and in television have been regrouped in a separate catalogue.

PART ONE

I - TECHNICAL INFORMATION

I.1 - Introduction

The operation of grid tubes is based on the movement of electrons from one source, the cathode, toward a collector, the anode. One or more grids between these two sources serve to modulate the number of electrons as a function of time.

If one applies to a diode, i.e., a tube made up of a cathode and an anode, a positive voltage increasing between these two electrodes, the following characteristic curve is obtained.

$$I_a = f(V_a)$$

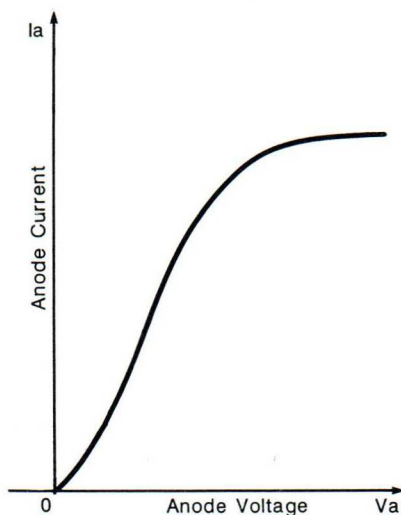

Fig. 1 - Characteristics of a diode

The part of the curve in which the electronic current increases rapidly as a function of the voltage, is called the space-charge zone. In fact, the presence of electrons near the cathode modifies the electric field produced by the anode. The current varies according to the LANGMUIR law :

$$I_a = P (V_a)^{3/2}$$

where P is called the « perveance ».

As the voltage is increased further, the cathode reaches its saturation point, which is a function of the temperature and the nature of the emissive body. The saturation value of the current per unit area is expressed by the RICHARDSON-DUSHMAN formula :

$$J = A.T^2.\exp(-W_s/kT)$$

W_s is a parameter related to the extraction of electrons from the cathode,
 T is the temperature of the cathode
 k is the BOLTZMANN constant
 A is the RICHARDSON constant.

Usually, the current does not reach a plateau because of the non-negligible effect of the electric field (SCHOTTKY effect).

The tubes operate in the space charge zone. The increase in the characteristic curve is determined by the tube geometric parameters. The ratio :

$$P = I_a / (V_a)^{3/2}$$

depends only on the tube geometry.

I.2 - Triodes

The triode is a vacuum tube made up of a cathode, a grid and an anode. The grid, placed between the cathode and the anode, controls the flow of electrons between these two electrodes. The grid acts by its electric field and should intercept as few electrons as possible.

Basic Mechanisms

When the grid voltage is sufficiently negative, the potential near the cathode is negative everywhere and no electrons can escape, therefore I_a and I_g are equal to zero. When the grid becomes less negative, cathode emission starts and the anode current I_a increases (see Figure 2). Finally, when the grid becomes positive, the cathode current continues to increase, but an increasing portion flows to the grid (I_g).

Figure 2 shows that small variations of the grid voltage create large changes in the anode current. It is possible to design amplifiers and oscillators using this effect, by placing the appropriate circuit in series with the grid and anode connections. The fact that small changes in the grid voltage can cause large excursions of the anode current has led to this basic grid being called the control grid.

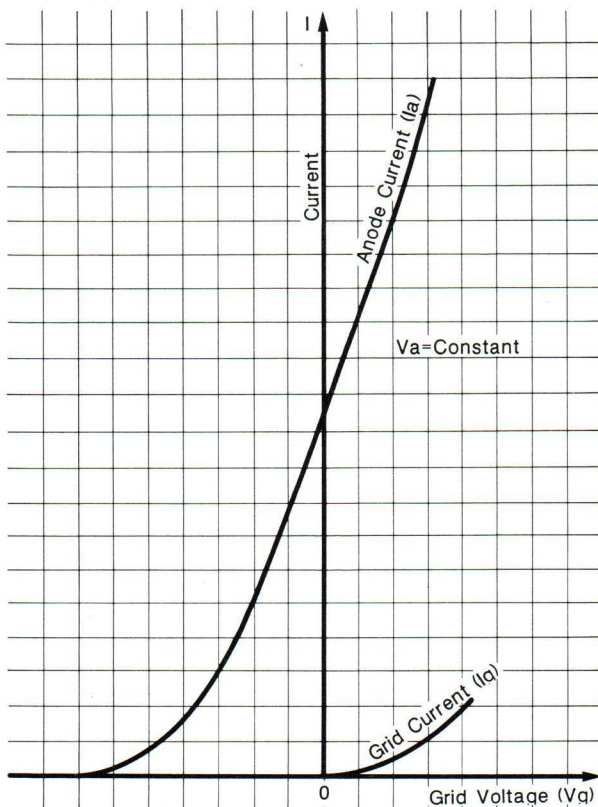

Characteristic curves

The currents I_a and I_g depend upon the voltages V_a and V_g . This relationship is usually represented by assigning a series of fixed values to one of the three parameters I_a , V_a or V_g and then tracing the set of curves that relate the other two parameters. Of the three possible sets of curves, the most commonly used is the set known as the constant-current characteristics (Figure 3).

The idea of an equivalent diode, in which the cathode current depends only upon $V_g + V_a/m$, (m is the tube amplification factor equal to $\Delta V_a/\Delta V_g$ at constant I_a), leads one to expect that for a zero or very small grid current, the set of curves for fixed values of I_a will be composed of parallel straight lines of slope $-1/m$ (Figure 3).

The appearance of grid current modifies the form of the set of curves; the lower the anode voltage and the higher the grid voltage, the greater this modification is (see the left side of the set of curves in Figure 3).

Parameters characterizing triode operation

Three fundamental quantities characterize the triode :

- 1) μ , the amplification factor, a dimensionless number, which is equal to the slope of the constant I_a curves (see Figure 3) ;
- 2) s , the transconductance (mA/V) is the slope of the constant V_a curves;
- 3) R_i , the internal resistance (Ω), is the inverse slope of the constant V_g curves.

Because μ depends very little upon the operating point (except when there is a strong grid current), it best characterizes the triode. On the other hand, both the transconductance and R_i can only be given for a specified operating point.

Figure 2 - Grid influence on the anode current in a triode

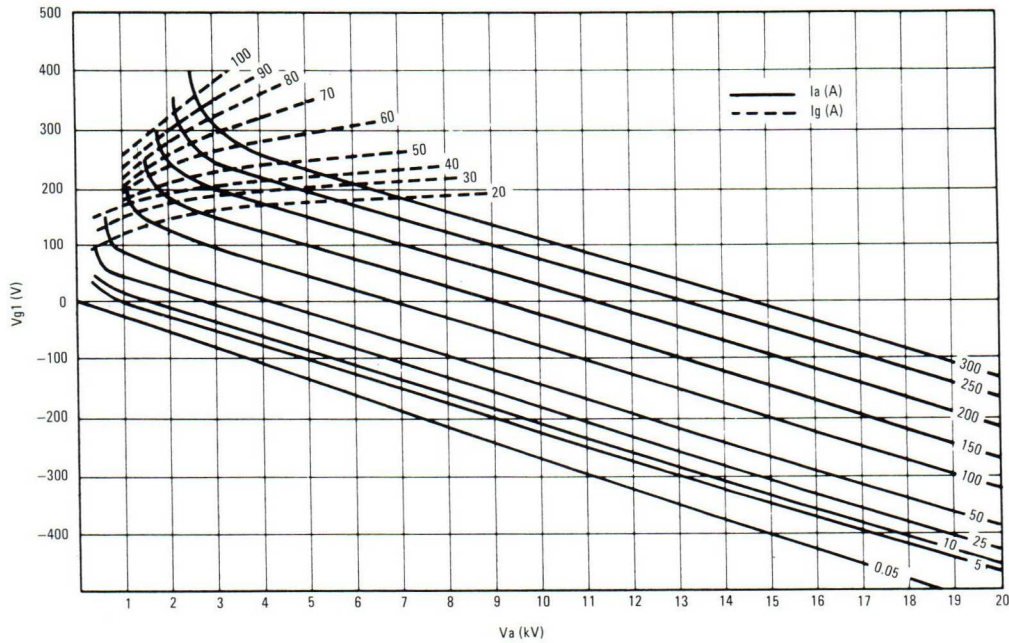

Figure 3 - Constant-current characteristics of a triode

I.3 - Tetrodes

Under carrier conditions, the grid-to-anode coupling capacitance limits the performance of the triode. A second grid may be inserted between the control grid and the anode to avoid this inconvenience. Operated at a fixed voltage this electrode constitutes an electrostatic screen that reduces the control grid-to-anode interelectrode capacitance, hence its name: screen grid.

Basic Mechanism

The control grid serves the same purpose in a tetrode as in a triode. The screen grid, however, held at a positive voltage gives rise to an electronic current, a major part of which reaches the anode. The variations of the anode voltage influence the anode current only slightly thus the functions of generation and collection of electrons are practically independent. It is very important to carefully regulate the voltage of the screen grid. Any surface, struck by electrons, emits - according to its nature and the characteristics of the striking beam - secondary electrons. The material which makes up the grid must have a very small secondary emission coefficient to avoid variations in the screen grid current and possible subsequent problems in the startup or operation of the tube.

Characteristic Curve

The most frequently used curves are the constant current curves which are drawn for fixed values of the screen grid voltage, i.e. :

$$V_{g1} = f(V_a) \quad I_a \text{ and } V_{g2} \text{ constant}$$

The fundamental parameters which characterize the operation of the tetrode are (see Figure 4) :

1) - the amplification factor μ_{g1g2} , which is equal to the slope of the constant current curves:

$$\mu_{g1g2} = \frac{\Delta V_{g2}}{\Delta V_{g1}}, \quad I_a \text{ and } V_a \text{ constant}$$

2) - the transconductance s , which is equal to the ratio of the anode current variations to the control grid voltage variations for a given operating point ;

$$s = \frac{\Delta I_a}{\Delta V_{g1}}, \quad V_a \text{ and } V_{g2} \text{ constant}$$

3) - the internal resistance R_i , which is the inverse of the slope of the constant V_{g2} curves:

$$R_i = \frac{\Delta V_a}{\Delta I_a}, \quad V_{g1} \text{ and } V_{g2} \text{ constant}$$

μ_{g1g2} is the main characteristic of a tetrode. Only an estimate of the transconductance can be given because its value depends on the constant V_{g2} curves.

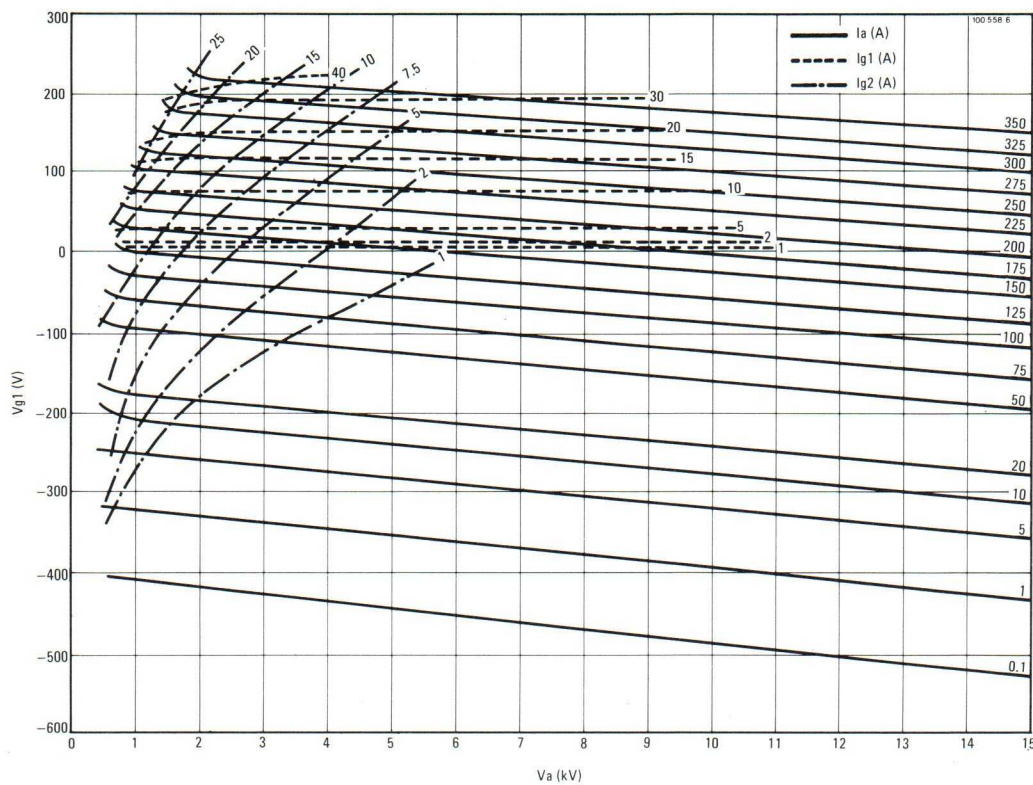

Figure 4 - Constant current characteristics of a tetrode

II - USE OF TUBES IN RADIOBROADCASTING

II.1 - Characteristics of High Power Transmitters

The rapid technological evolution of power grid tubes and electronic circuits allows equipment manufacturers to design high power transmitters reaching improved performance standards with increasing system reliability and ease of operation.

The most demanded characteristics are :

- operation at high frequencies (SW band),
- reduced energy consumption due to the use of new modulation systems and to the more frequent use of the SSB transmission system (which also helps to limit spectrum crowding),
- reduction in the number of tubes used.

II.2 - Factors Influencing the Choice of a Power Grid Tube

The designer of a radiobroadcasting transmitter must consider the following factors when choosing a tube:

- The power that the tube must supply to the antenna. In the final output stage, modern transmitters generally use only one tube.
- The efficiency which can be reached, considering the mode of operation reserved for the tube (class of operation, LF/RF amplification, DSB or SSB transmitters).
- Linearity, which is closely related to distortion or/and intermodulation products.
- The high voltage holding capability needed to handle the high power levels at high efficiency.

- The gain, which together with the progress made in solid state input stages, can help to limit the number of tubes in a transmitter.
- The interelectrode capacitances which influence the above factors (gain, linearity, efficiency).
- The stability during power and/or voltage surges caused by any difficulties met during normal operation.

Continuing research to improve these factors has led to an increased use of tetrodes rather than triodes in power transmitters.

The power grid tube department of Thomson-CSF has also developed and incorporated into current production two original manufacturing technologies (the pyrolytic graphite and the Hypervapotron® cooling system), which allow for optimal tetrode use.

Pyrolytic Graphite

This material has completely modified the internal structure of the tubes by leading to the development of Pyrobloc® grids. Its major advantages are :

- Excellent geometric definition, allowing perfect grid alignment (reduced screen-grid currents).
- Negligible thermal expansion which allows the achievement of small, reproducible interelectrode

spacing (higher gain and better resistance to high voltages).

- Improved mechanical stability at high temperatures encountered during overloads.
- High thermal conductivity and emissive capability close to that of the black body ; thus excellent dissipation possibilities (lower voltages leading to improved efficiency).
- Low secondary emission coefficient (increased linearity).

The Hypervapotron® System

The secret of the extraordinary Hypervapotron®-cooled anodes lies in an aggregate-complex boiling phenomenon involving an instant condensation of water vapor. This system has made possible :

- a reduction of system dimensions, thus decreasing stray anode-to-ground capacitances ;
- an extension of maximum anode dissipation limits far above nominal operating conditions, leaving a substantial safety margin.

Using these two technologies, we manufacture tubes with smaller dimensions operating at higher frequencies. Tube characteristics remain unchanged because the reduction of cathode and grid surface areas is compensated by smaller interelectrode spacing.

II.3 - Comparative Table : Triodes/Tetrodes

Desired characteristics	Triodes	Tetrodes
Operations in the SW band	difficult (high grid-to-anode capacitance)	easier
Gain	limited by the grid-to-anode capacitance	higher
Anode efficiency	limited by the power dissipated	higher (due to lower residual voltage)
Linearity	poor	good
Operation in RF-modulated output stages	limited by the power dissipated on the grid	easier

III - TECHNOLOGY

III.1 - Thoriated-Tungsten Cathodes

The thoriated-tungsten material has been chosen and used to manufacture cathodes because of its excellent property in withstanding high voltages.

The thoriated-tungsten cathode is an improved version of the pure tungsten cathodes used previously, which exhibited several disadvantages, including an extremely high operating temperature and overly rapid depletion. By arranging for a monoatomic layer of thorium to be present at the surface of the tungsten cathode, sufficient emission density can be obtained at a temperature of only 1900 to 2000 °K.

The cathode is shaped like a cylindrical « cage » (see Figure 5), made of several wires heated directly by the current passing through them. This structure is obtained by winding these wires on a cylindrical mandrel, in two layers that cross each other askew and by welding each crossing point. Then the cage is welded at each end to plates, through which the heating current is channeled.

The thin wire, only a few tenths of a millimeter in diameter, is made of tungsten, containing a small percentage of thorium oxide. The latter is chemically reduced and the cathode becomes activated by raising its temperature to 2800 °K for several minutes. Thorium is generated by this process and diffuses towards the surface of the wire where it forms a monoatomic layer.



Figure 5 - Cathode of a tetrode

This process leads to cathodes having a low evaporation rate, which allows them to generate high current densities at increased temperatures (example : 2.5 A/cm² at saturation). Carburized thoriated-tungsten cathodes also withstand more readily the effects of residual gases and ion bombardment in the tube, and in this respect, they are greatly superior to oxide cathodes. This makes thoriated-tungsten cathodes the preferred type for high-power tubes, with high operating voltages.

III.2 - Grids

Necessary Grid Qualities

The shape of the control grid and its distance from the cathode and, to a lesser extent, from the anode define the operating characteristics of a triode. The necessary reduction of the grid current to a minimum requires for the grid to be highly transparent. In order to minimize the grid current in the tetrode, the two grids must be aligned precisely, so that the electrons passing through the first (the control grid) are likely to pass through the second (the screen grid). Finally, normal tube operation requires having screen grid voltage remain significantly lower than anode voltage and this leads to decreased spacing between screen and control grids in tube construction.

Development of the Pyrobloc[®] Grid

Since conventional grid materials could not meet the combined requirement of compactness and high power, a new grid material was sought. Thomson-CSF research efforts led to use of pyrolytic graphite, in an entirely new type of grid, patented by Thomson-CSF as the Pyrobloc[®] grid.

Pyrolytic or oriented graphite, is a form of crystallized carbon produced by the decomposition of a hydrocarbon gas at very high temperature under controlled environmental conditions. A layer of pyrolytic graphite is deposited on a special blank, the layer's thickness being proportional to the time that deposition is allowed to continue. The structure and mechanical properties of the deposited graphite depend upon the imposed conditions.

Four groups of properties make pyrolytic graphite a clearly superior material for making power-tube grids :

Thermal properties

Figure 6 shows the thermal conductivity of various materials, as a function of the temperature. As can be seen, the thermal conductivity of pyrolytic graphite in a direction parallel to the plane of deposition [ab] is on the order of copper or tungsten. In the perpendicular direction [c], however, its thermal conductivity is even lower than that of stabilized zirconia.

This combination of properties allows the power dissipated as heat in a Pyrobloc® grid to be easily and efficiently transferred to its support. This transfer is facilitated by the one-piece construction of these grids.

Looking now at thermal expansion, Figure 7 shows that α is very low in the [ab] direction for pyrolytic graphite. It follows that the variation in diameter of a Pyrobloc® grid is negligible at normal operating temperatures. This allows the extremely close spacing between screen and control grids.

In addition, the excellent resistance to thermal shock and the superior high temperature stability of pyrolytic graphite enables Pyrobloc® grids to withstand short-term overloads with no damage, unlike conventional metal grids, which would very likely be destroyed under the same abnormal operating conditions.

Finally, one of the most important thermal properties of pyrolytic graphite is that it is a near black-body material with a very high heat-radiation capacity.

Reduced grid emission

It is well known that graphite secondary-emission effects are much less pronounced than those of conventional grid materials. The much lower operating temperature of Pyrobloc® grids also causes a significant reduction in the thermal emission from the coating of cathodic material inevitably deposited on the grids.

Mechanical properties

The mechanical strength of pyrolytic graphite compares more than favorably to that of the other usual grid materials. To cite only the most important characteristics :

- ultimate flexural strength, [ab] direction 1700 kg/cm²
- ultimate tensile strength, [ab] direction 1100 kg/cm²
- ultimate compressive strength, [ab] direction 1500 kg/cm²
- ultimate compressive strength, [c] direction 5000 kg/cm²

Unlike other grid materials, pyrolytic graphite strength increases with temperature. Also, due to its excellent stability at high temperatures (e.g., at 1850 °C, vapor pressure is close to 10⁻⁷ torr), a Pyrobloc® grid can be operated at the same temperature as a thoriated-tungsten cathode.

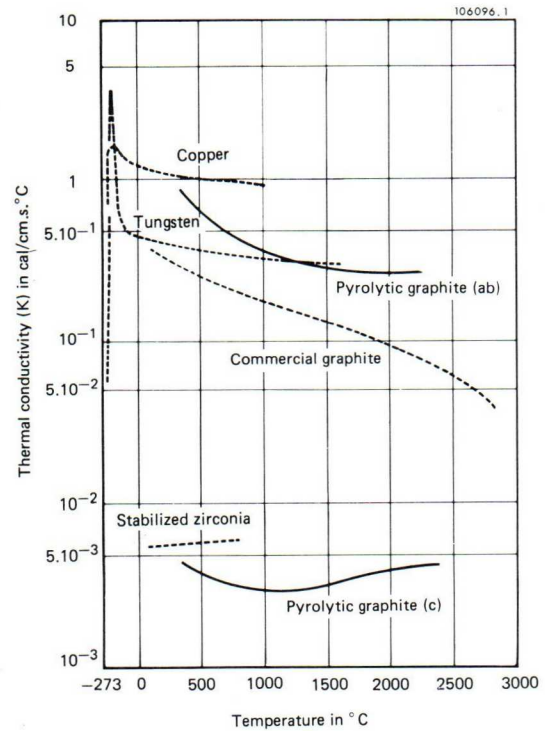

Figure 6 - Thermal conductivity of various materials

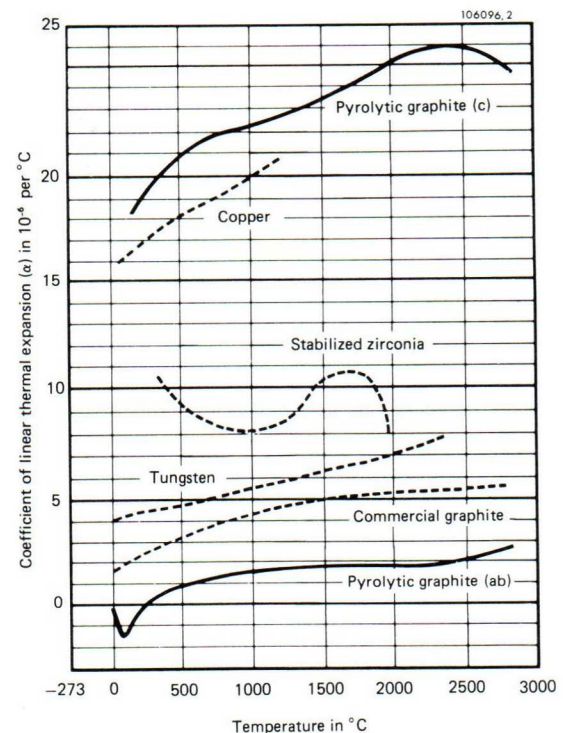

Figure 7 - Thermal expansion coefficient of various materials

Electrical properties

Electrical anisotropy is an inherent characteristic of pyrolytic materials. This explains the large difference in the electrical resistivity of pyrolytic graphite in the [ab] and [c] directions (Figure 8). In addition, one notes that the electrical resistivity in the [ab] direction remains nearly constant (and at a minimum) for the usual operating temperatures of power grid tubes. It follows that Pyrobloc® grids conduct almost as well as coated-metal grids.

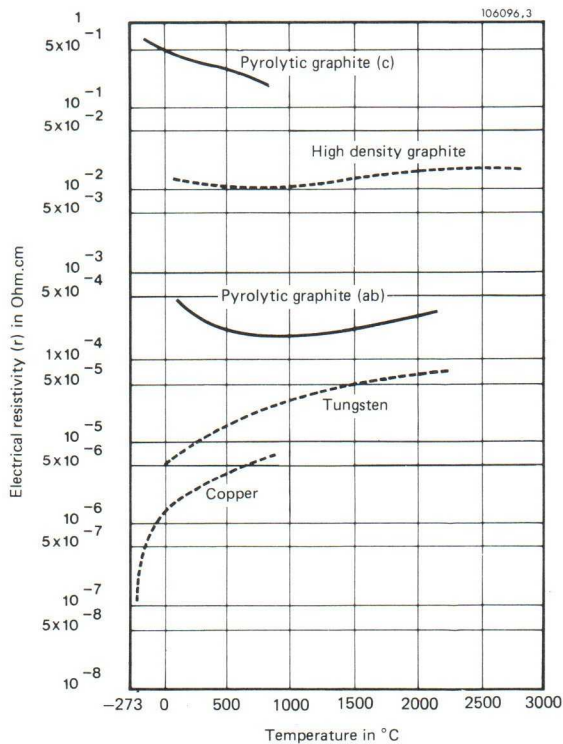

Figure 8 - Comparison of electrical resistivity

Manufacturing Pyrobloc® Grids

To make the industrial production of Pyrobloc® pyrolytic-graphite grids practical, a number of difficult problems had to be successfully overcome. One of the first of these was that of graphite supply. Commercially available graphite was found to be unsuitable, due to the impurities it contains. This problem was finally resolved by developing the high-temperature pyrolytic-graphite deposition process previously described, resulting in the production of one-piece grid « castings ». All of the grid elements (cap, mesh, and supporting base) form a continuous structure, no welding or mechanical assembly being necessary.

An original processing method was then developed to produce any type of grid mesh desired from these « castings » (see Figure 9), with an individual strand cross section as small as 0.01

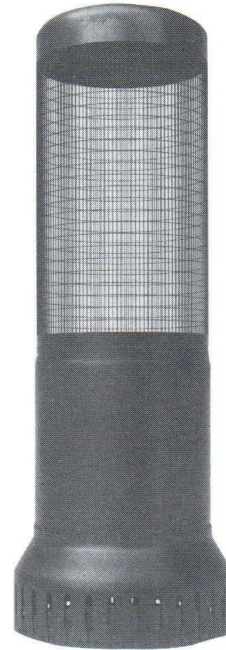

Figure 9 - Pyrobloc® grid of a tetrode

mm² and extremely high precision. All of the original manufacturing and processing techniques developed in the Pyrobloc® grid program have been patented by Thomson-CSF.

III.3 - Anodes

In general, the anodes of power grid tubes are massive electrodes, which, in coaxial tubes, surround all of the other electrodes. Their structure is essentially determined by the power that they must dissipate in the form of heat. One constraint often imposed on the anode cooling system is the fact that the cathode is operated at ground potential. This requires that insulation be provided between the anode and ground, and that this insulation be able to withstand the maximum value of the anode voltage.

For the most commonly encountered power levels, the anode must be cooled by other than natural radiation, conduction or convection. These tubes are therefore cooled by forced air, circulating water, or by vapor-related methods.



Figure 10 - An air-cooled tetrode

Forced-Air Cooling

The dissipation per unit area can be greatly increased (about 20 times) over that possible in naturally cooled tubes by blowing air onto the tube outer surface at a high velocity (30 m/sec, for example). In external-anode types, a finned heat radiator is welded to the anode (see Figure 10). In the tube shown, this radiator is enclosed in a cylinder that forces the cooling air to flow between the fins, which are designed to require only a slight overpressure. This device has the advantage of providing a simple way of anode insulation from ground, but necessitates high-rate fans that are bulky and noisy, use a non-negligible amount of power, and can be a source of vibrations. Furthermore, the radiator considerably increases the tube weight, and only about 20 kW of power can be dissipated by this means.

Supervapotron® Cooling

An efficient thermal exchange is obtained by the direct vaporization of water in contact with a copper anode having massive protuberances. The water vapor is channeled out and then condensed into an external water tank.

The Supervapotron® anode cooling is effective for as long as a minimum anode surface remains in contact with water.

The use of a Vapodyne® system keeps the water level within given limits, ensures vapor condensation in a closed water circuit and cools the tube. This system must be tested according to the data sheet of the tube being used.

Hypervapotron® Cooling

The Hypervapotron® advanced circulating-water cooling system is the outgrowth and latest result of the discovery of the Vapotron® effect at Thomson-CSF since the early 1950's.

This cooling process lies in the combination of two phenomena: First, the aggregate complex boiling phenomenon within the narrow slots on the outside surface of the anode structure, and, second, the instant condensation of the water vapor in a fast flow of water which circulates in a water jacket at right angles to these slots.

Figure 12 illustrates the Hypervapotron® cooling technique. The gap between two facing surfaces is reduced to a narrow slot, and aggregate (film and bubble forming) boiling takes place. Furthermore, a natural pulsating regime is established. First (Fig. 12a), the vapor produced by the complex boiling builds up in the slot, then it is expelled at high velocity (Fig. 12b) and quickly condensed in the flow of water across the slots, and, finally, a simultaneous suction action draws water back in to replenish the slot (Fig. 12c).

The immediate condensation of the vapor reduces the disturbing effects of the large amount of water vapor generated and eliminates any need for an external condenser.

The water outlet temperature can reach any value as long as it remains under 100 °C at atmospheric pressure.



Figure 11 - A Hypervapotron®-cooled tube

The extremely hot outlet water can be routed through a water/water heat exchanger, to provide a secondary hot-water circuit for building heating at no additional cost, or for other uses.

The Hypervapotron[®] method can be continuously rated at 1 to 2 kW/cm² dissipation. Usually, Hypervapotron[®] tubes are operated at 300 W/cm², which gives a large margin of operating safety.

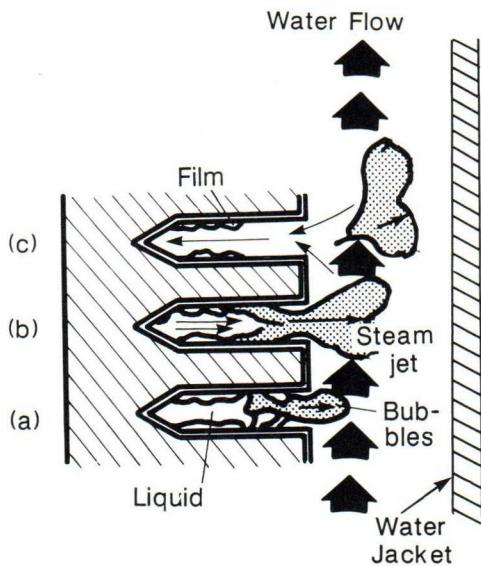

Figure 12 - Hypervapotron[®] anode cross-section, showing operation

III.4 - Ceramic Insulators

A power grid tube ceramic insulator (Figure 13) must have the following properties :

- electrical insulation between the different electrode terminals,
- perfect vacuum-tightness,
- good mechanical stability at high operating temperatures.

Ceramics containing a high percentage of alumina have these properties and allow the development of more powerful tubes, or of tubes operating at higher voltages.

Their main physical characteristics are :

- dielectric rigidity : 20 kV/mm
- electric conductivity at 20 °C : less than $10^{-12} \Omega^{-1} \text{ m}^{-1}$
- loss factor at 1 MHz : approximately 10^{-4}
- good thermal conductivity ($30 \text{ Wm}^{-1} \text{ }^\circ\text{C}^{-1}$) leading to a good resistance to thermal shocks - good mechanical stability at high temperatures (melting point is at 1600 °C which is well above normal operating temperature).

Thanks to their overall physical characteristics, on one hand, and the advantages of modern production methods on the other, ceramic insulators can be manufactured to very tight physical tolerances, that enable extremely high centering precision during tube manufacturing. The ceramic-to-metal seals obtained through sophisticated procedures can withstand elevated operating temperatures without affecting the life of the tube.

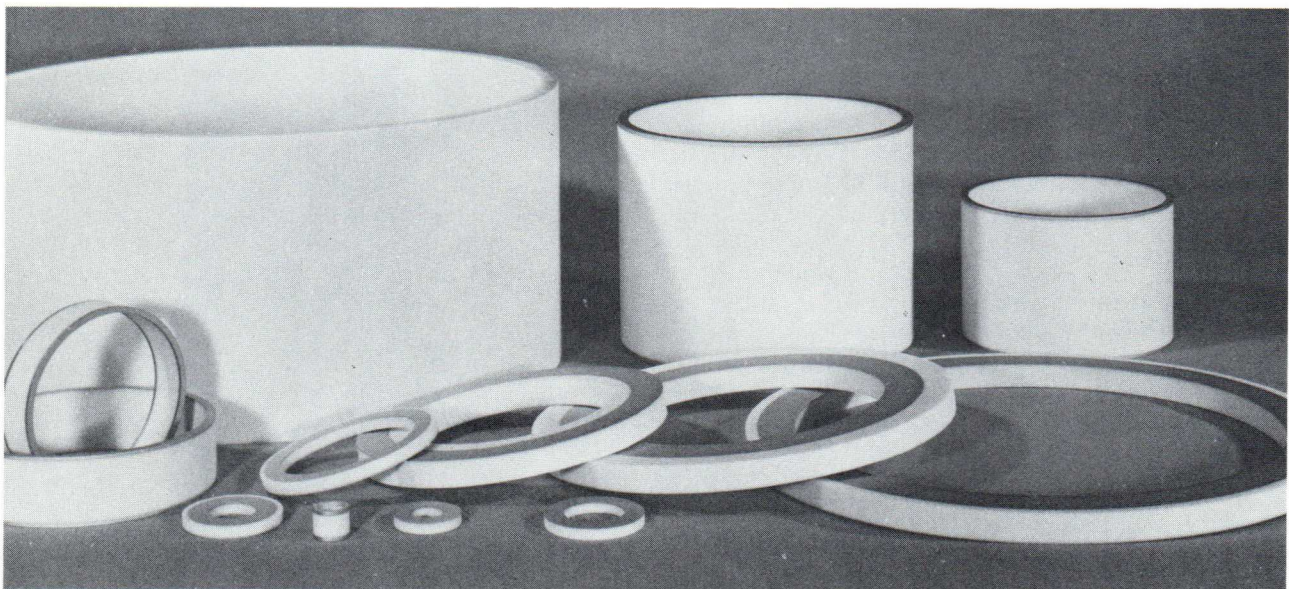

Figure 13 - Ceramic insulators of various power grid tubes

IV - CONNECTORS

Electron tubes are designed to be mounted vertically on their electrical connectors (Figure 14), which also provide mechanical support, while allowing to cool the electrode terminals and the ceramics by forced air.

The tube/connector assembly has been designed to secure operation of the tube at high frequencies.

- The connector electrode fingers are made of a silver-plated beryllium copper alloy. Their elasticity allows good contact pressure and the conduction of high currents.
- The connector channels the flow of cooling air onto the terminals and through holes in these which help in cooling efficiently the ceramic-metal seals with air.

The air flow and pressure must conform to the data sheets to make sure that the temperature of the terminals, the ceramic-metal seals and the ceramics, does not exceed the maximum temperature specified in the data sheet of the tube being used.

It is essential to correctly position the tube in its connector. The tube weight must be supported by the anode terminal. The plane of the terminal is used as a reference plane and the position of the connector must be precisely defined according to this reference plane.

Proper cooling is achieved under these conditions since the air flow in the terminals remain free and the electrical connection of electrodes is made in the contact zones indicated in the data sheets.

Precaution is required when installing and removing tubes to avoid flattening or breaking the connector fingers. Connector finger damage can increase electrical contact resistance, leading to local overheating and possible damage of the electrode terminals. Incorrect electrode cooling also causes overheating of the fingers and reduces their elasticity. Periodical checking of the connector fingers and their adequate maintenance is necessary.

- The connector is equipped with cathode-to-ground and screen-to-grid insulators made of KAPTON * sheets metallized on both sides, securing high capacitance values and high insulated voltages. However, these capacitances are not sufficient at low frequencies and must be supplemented with additional specific capacitors.

- The control grid-to-ground and screen grid-to-ground spark-gaps, regulated in the factory, help protect the tube by limiting accidental electrode over-voltage.

* KAPTON is a registered trademark of Dupont de Nemours (USA).

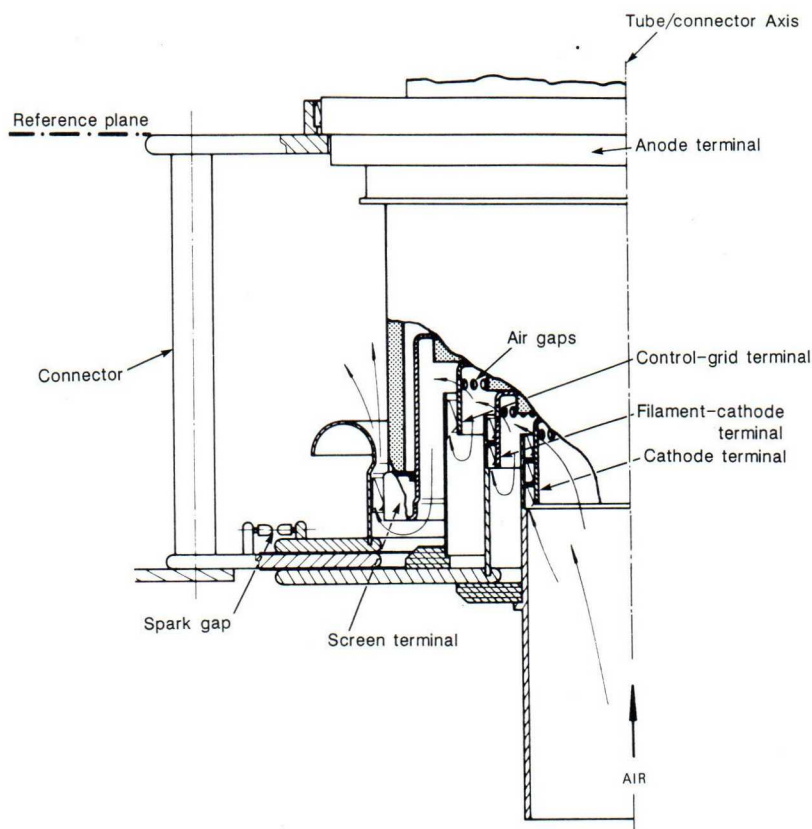

Figure 14 - Cross-section of the connector of a tetrode

V - OPERATING INFORMATION AND RECOMMENDATIONS

Thomson-CSF triodes and tetrodes for radiobroadcasting are designed and manufactured to provide high performance and long operating lifetime.

When these tubes are installed in circuits fabricated or approved by Thomson-CSF, the user is assured that the tubes are operating under optimal conditions.

However, the user must take a few important precautions and follow the recommended operating procedures in order to reach the best performance which these tubes were designed for, regardless of the circuit designed around. Taking enough time to carefully read these paragraphs and applying the suggestions given here helps in getting the best results in operating these tubes.

If you have any questions which are not answered by the information given here, or if you need assistance with your specific requirement, please contact our experienced application engineers via our headquarters, or via your local Thomson-CSF Electron Tube Division representative.

V.1 - Cathodes and Temperature

The cathode mechanical stability has always been an important factor in enhancing the reliability and the lifetime of a power grid tube. Considering the short distance between the cathode and the control grid, this factor is fundamental in modern radiobroadcasting tubes. Three principal parameters must be considered :

Heater Voltage

Transmitter tubes are supplied with directly heated thoriated-tungsten cathodes. The lifetime of a tube is primarily related to the temperature of its cathode. This temperature is a result not only of the heating power - the heater voltage applied to the cathode - but also of the combination of the power dissipated on the grids, the cathode current, and of the RF losses. For this reason, the heater voltage does not depend on the tube alone but must be defined according to the specific operating conditions. This is why the users are urged to forward these conditions to Thomson-CSF application engineers who will in turn advise the optimal heating parameters.

Nevertheless, Thomson-CSF power grid tubes data sheets indicate approximate values of the heater voltage and current (considering that no other cathode heating factors interfere), in order to help transmitter manufacturers design the appropriate heating transformer.

Regulation

It is also necessary to regulate it in order to reach a longer lifetime of the cathode. The standard tolerance is $\pm 2\%$. It is important to notice that a heater voltage which is higher or lower than the selected value is harmful to the tube in both cases; overheating causes rapid evaporation of the cathode emissive material, while a lower voltage causes cathode deterioration. In both cases, the life of the tube is shortened.

Application and Shutdown of the Heater Voltage

When the heater voltage is applied, it is necessary to limit the surge current considering the low resistance of the cold cathode, and to take into account other thermal factors as well.

When applying the heater voltage to a cage-type cathode, the tungsten wires expand immediately due to their low thermal inertia, whereas the cathode support - made up of massive parts - heats and expands more slowly.

This differential expansion can cause permanent damage to the cathode wire, together with a modification of the tube characteristics and occasionally electric arcs or intermittent short-circuits between the cathode and the control grid, and tripping off of the power supply circuit breakers. It is therefore necessary to take a few basic precautions when applying the heater voltage.

The surge current at heater voltage turn-on can be limited :

- by a leakage transformer. The general characteristics given on the tube data sheet specify the maximum surge current at heater voltage turn-on and this value is used to design the transformer.

- by a progressive or stepwise application of the heater voltage. This solution is advantageous since the corresponding time delay allows the cathode assembly (cathode and its support) to make up for differences caused by expansion. An appropriate definition of the steps and their duration is important. This solution has one drawback, that is to require a delay in operating the tube until its cathode reaches the correct temperature. This delay is not always acceptable in some applications (emergency broadcasting, for example).

Another process is therefore recommended which is based on permanent underheating of the cathode, also called « black heating » ; in this case, the full heater voltage can be applied directly (Figure 15a) or progressively (Figure 15b).

While this process is recommended for medium power tubes, it is mandatory for high power tubes, or under the conditions which cause more than one heater voltage shutdown per day.

The black-heating process consists of permanently maintaining a reduced heater voltage (approximately 1/4 of the operating value) in order to keep the cathode at about half its working temperature when the transmitter is off the air.

Under these circumstances :

- The heater power consumed is reduced to approximately 10% of that consumed in normal operation. No cooling is necessary, however the cooling water must be free to circulate (thermosiphon effect).
- The tube life is not diminished by blackheating time, because the cathode temperature is reduced.

Thomson-CSF guaranteed tube lifetime has the same meaning in all cases and includes: only the time duration when the voltage is at its nominal value. When the cathode is at black-heating temperature, the cathode surge current is limited by the resistance of the «blackheated» cathode. Therefore, a leakage transformer is not required.

If it is necessary, full heater voltage can be applied directly, starting from its « black heat » level, as long as the heater current does not exceed the value given in the tube data sheet.

The heater switch must be protected. The protection device of the tube cooling systems (terminals and anode) must be designed in such a way that the heater circuit breaker opens

immediately after a cooling detect is encountered. When the heater is shut down, it is necessary to maintain the cooling of the terminals and the anode for at least three minutes. In case the transmitter shuts down on its own, it is recommended to pass through the black heating during the postventilation period of three minutes defined earlier.

In any case, it is recommended to avoid heater voltage shutdowns which cause strains on the cathode structure. It is also advisable to maintain the nominal heater voltage during relatively short transmitter interruptions such as those encountered in SW transmitter operation.

V.2 - Grids

Thanks to the technology of pyrolytic graphite, Thomson-CSF tubes achieve high performance levels. The main electrical advantages are : less drag on the characteristics (left side of curve Figure 2), reduced risk in having both unwanted thermal or secondary emissions, and increased dissipation capability.

Thus a low impedance on grid power supplies becomes less important, and regulation is easier with Pyrobloc® grids than with classical grids.

In all cases, a protection device against overcurrents must be provided [overcurrent interlock, with a high speed cutoff system (100 milliseconds max.), regulated at 1.5 times the normal operating current].

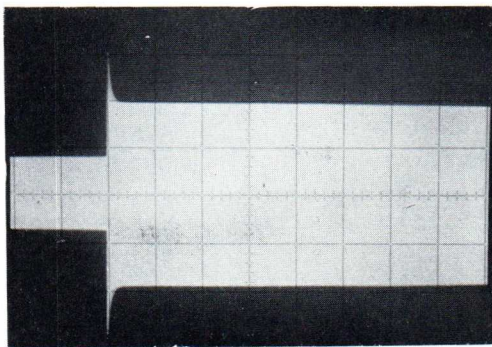

(a)*

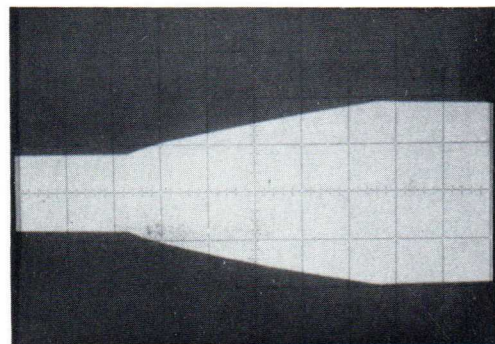

(b)

Figure 15 - Heating current under black-heating conditions

* If the full heater voltage is applied directly (Figure 15a), the surge current I_s must not exceed the maximum value specified in the tube data sheet.

Furthermore, a spark-gap is required between each grid and the ground to limit possible overvoltages.

These spark-gaps are mounted on Thomson-CSF connectors described in the tube data sheets and in Figure 14.

V.3 - Anodes

Hypervapotron[®] anode cooling provides a large safety margin for anode dissipation and for short overloads which might occur.

In addition to the general safety instructions for high voltage operation, the tube protection devices must also act on the anode power supply. These devices include :

- anode cooling interlocks,
- protection of heating voltage and control-grid voltage,
- anode, control grid, and screen grid overcurrent devices,
- other protection devices of the transmitter circuit and for user's safety.

The tube must also be protected by an arc detector and against overloads which could result from possible mismatching.

The installation of a « crow-bar » device is recommended to divert the discharge current from the HV power supply filter capacitor in case of arcing. The « crow-bar » device is set by bringing the HV rectifier to full voltage and adjusting the overcurrent relay to its standard sensitivity. A short-circuit is initiated between the anode power supply cables and the cathode through a copper wire. The diameter of this wire is specified in the tube data sheet and its length is about 2 cm per kV. The « crow-bar » must act to shut down the HV before this wire melts.

V.4 - Applying Tube Voltages

The tube voltages should be applied in the following sequence : cathode-heater voltage, bias, anode voltage, screen-grid voltage, and RF drive. At shutdown, the reverse order should be followed for removing voltages from the tube. The time delay between two successive voltages of this sequence is typically that of a standard electromechanical relay.

V.5 - Cooling

It is necessary to cool :

- the anode,
- the ceramic insulators,
- the electrode terminals.

In all operations, cooling must be effective before the heater voltage is applied, and maintained for at least 3 minutes after shutdown.

The electrode terminals and the ceramics are cooled by filtered forced air. The air flow must be

carefully channeled in order to effectively cool the seals and the electrode terminals. The use of Thomson-CSF connectors for this purpose (see paragraph IV) is recommended.

The temperature of the ceramic-metal seals and the ceramics must not exceed the maximum temperature given in the tube data sheet.

An air flow and pressure protection device should be provided at the terminal inlet.

The anode can be cooled either by vaporization (Supervapotron[®] or Hypervapotron[®]), by the circulation of cooling water, or by forced air, depending on the power to be dissipated. Anode cooling by Hypervapotron[®] should be used above a determined power level.

Hypervapotron[®] Cooling

Each individual tube data sheet specifies the water pressure and flow rate. The cooling water must be distilled but not completely degassed, and have a resistivity greater than 500 kΩ-cm.

Hypervapotron[®] tubes are delivered with their integral water jackets and with water inlets and outlets marked (« IN » and « OUT » and with the colors BLUE for the inlet and RED for the outlet). The incoming cooling water must always be connected to the INLET and the outgoing hot water must always be evacuated from the OUTLET.

Protection devices are needed for the following parameters to ensure the tube dissipation capability :

- pressure at the inlet,
- flow,
- water resistivity,
- water temperature at the inlet and at the outlet.

Hypervapotron[®] reliability is enhanced by :

- regeneration of water, using some type of resin, to maintain the correct resistivity ;
- filtration of the cooling water to eliminate all solid particles which could obstruct the flow of the cooling water and cause local overheating of the anode.

Forced Air Cooling

Forced air cooling is chosen for tubes of 20 kW maximum anode dissipation.

The cooling air must be correctly filtered in order to avoid all clogging, which could reduce the air flow and cause overdissipation on the anode.

The air filter must be cleaned periodically to keep the flow at its required value.

The tube should be protected by interlocks monitoring the inlet air pressure and the outlet air flow to ensure proper cooling at all times.

The air temperature at the amplifier cooling-air outlet must never exceed the safe maximum rating of 100 °C. Therefore, a temperature-monitoring device must provide prompt warning of an excessive outlet air temperature, which indicates amplifier misadjustment or malfunction and must act on the tube protection interlocks.

Forced air cooling of the anode and the other electrodes is described in the tube data sheet, for the recommended connector at a standard temperature of 25 °C at sea level.

Air Cooling and Transmitter Site

When the altitude at the transmitter site is above sea level and/or the ambient temperature differs from 25 °C, the forced-air cooling requirements for the tube must be adjusted for the variation of the air density, which affects the choice of a fan.

- Adjusting the air-flow volume is done by multiplying the standard value by the coefficient γ_a :

$$\gamma_a = \frac{P_o}{P} \cdot \frac{273 + t_{in}}{273 + 25}$$

where :

P_o : atmospheric pressure at sea level

P : atmospheric pressure at the transmitter site

t_{in} : inlet-air temperature (in °C)

The coefficient γ_a modifies the air-flow volume in order to keep the air mass per unit time constant.

In those situations where the air outlet temperature t_{out} exceeds 100 °C, a second adjustment has to be introduced. This is done by multiplying the air-flow volume by γ_b :

$$\gamma_b = \frac{t_{out} - 25}{100 - t_{in}}$$

- Pressure drop is adjusted in the same way as for the air-flow volume, by multiplying it by γ_a or $\gamma_a \times \gamma_b$ if the outlet air temperature is more than 100 °C.

Selection of the Cooling Fan

The air flow versus pressure drop curve supplied by fan manufacturers is, in general, valid only at sea level and at an ambient temperature of about 20 °C. The cooling fan must deliver the air flow necessary for correct cooling at the transmitter altitude and ambient temperature. As the air flow is unchanged for constant fan speed, the pressure drop has to be adjusted by using the coefficients γ_a and γ_b .

The adjustment of the transmitter site values into standard conditions values is calculated as follows :

- air-flow :

$$q = \gamma \cdot q_n$$

where :

q_n = air flow specified in the tube data sheet (standard conditions)

q = air flow of the fan to be selected

= γ_a or $\gamma_a \cdot \gamma_b$, according to the conditions at the transmitter site.

- pressure drop :

$$P = P_n \cdot \gamma^2$$

where :

P_n = pressure drop specified in the tube data sheet
 P = static pressure produced by the fan to be selected

= γ_a or $\gamma_a \cdot \gamma_b$ according to the conditions at the transmitter site.

Table 1 - Values of γ_a as a function of the local altitude and ambient temperature

Local ambient temp. (°C)	Local altitude in meters above sea level								
	0	500	1000	1500	2000	2500	3000	3500	4000
0	0.92	0.98	1.04	1.10	1.17	1.25	1.33	1.42	1.52
10	0.95	1.01	1.07	1.14	1.21	1.29	1.38	1.47	1.57
20	0.98	1.04	1.11	1.18	1.24	1.33	1.42	1.52	1.62
25	1.00	1.06	1.13	1.20	1.27	1.36	1.45	1.55	1.65
30	1.02	1.08	1.15	1.22	1.30	1.39	1.48	1.58	1.68
40	1.05	1.11	1.19	1.26	1.33	1.43	1.52	1.63	1.73
50	1.08	1.14	1.22	1.30	1.37	1.47	1.57	1.67	1.78

VI - MAINTENANCE

It is necessary to take good care of the equipment to ensure the long tube life. Regular maintenance must be carried out according to the transmitter instruction manual.

In case of defective transmitter operation, a breakdown of the interlocks can cause tube damage.

Important points which directly concern the tube and which must be looked at carefully include:

VI.1 - Systematic and Periodic Testing

Heating

Check the heater voltage at the connector terminals using a voltmeter with true rms readings (ferromagnetic, thermal, or digital).

If the voltage is not correct, before adjustment, check the regulator voltage at the heater supply input and the heater and heater/cathode contacts of the connector.

In the case where « blackheating » is used, check the voltage and the cooling water circuit.

Cooling

- Hypervapotron® and Supervapotron® systems
 - . verify the cleanliness and the resistivity of the water, and examine the antielectrolytic connections for signs of wear.
 - . eliminate all possible water leaks
- Supervapotron® system : check the water level
- Air cooling
 - . fan maintenance
 - . clean the air filters.

Automatic Protections and Interlocks

Check :

- The sequence of voltage application and timing
- The protection devices against overcurrents
- The rapid shutdown system ("crow-bar")
- The cooling interlocks :
 - . flow, temperature and pressure (air or water)
 - . The water level
 - . The water resistivity.

Connector and other accessories :

- It is necessary to keep the immediate environment of the tube in good condition, i.e. :
- Connectors and accessories for the connection of the tube electrodes
 - Connector contact fingers
 - Decoupling capacitors
 - Visual check and adjustment of the protection spark-gaps.

VI.2 - Replacing a Tube

When a tube stops operating, examine the circuits and the tube to correct any possible malfunctions before installing a new tube :

- traces of heating,
- traces of flashes,
- traces of poor contact.

The origin of such malfunctions could be :

- defective cooling system,
- improper tube positioning,
- aging of the contacts and loss of elasticity,
- poor condition of the decoupling capacitors,
- accidental circuit mismatch,
- defective damping circuits.

VII - TRANSPORTATION - HANDLING - STORAGE

The tube is delivered in a container which is specially designed to protect against shocks and vibrations which may occur under normal transportation conditions.

VII.1 - Receipt of the Tube

Checking the Tube in its Packing

Upon receipt of a tube, without removing it from its container, check for any damage which may have occurred during transportation. It is necessary :

- to inspect the inside and the outside of the container.
- to check the tilt detector(s) whenever provided on the container.
- using an ohmmeter, test the continuity of the filament and the absence of short-circuits between the electrodes.

For the Hypervapotron® and Supervapotron® tubes, this operation can be carried out without taking the tube out of its packing crate.

Check-up of the Tube out of its Packing

The high power Hypervapotron® and Supervapotron® cooled tubes are delivered mounted on a stand to ensure protection of the tube during storage :

- using a lifting attachment (Figure 16), remove the tube and the stand
- verify that the tube does not have any traces of shocks
- using a trolley with pneumatic wheels, move the tube and the stand close to the transmitter tube socket avoiding shocks
- following the directions of paragraph VII.3 « First Use », install the tube.

In Case of Damage

Refer to the instructions on the back of the delivery statement in the « Documents » envelope on the packing case and send a letter listing claims to the last shipper immediately.

VII.2 - Storage

The tube must be stored in a dry, dust-free place in a vertical position, either in their container or on their stand for the high power Hypervapotron® and Supervapotron® cooled tubes, or on shelves with the anode down for medium power air-cooled tubes.

The tubes are delivered with removable ceramic protectors which must stay in place during storage. Tube ceramics must be kept clean. Never use an abrasive or a metal pad to clean them.

VII.3 - First Use

Before being delivered, each Thomson-CSF tube is submitted to a complete series of factory tests to ensure that it operates according to its specifications.

When using the tube for the first time, it is necessary to perform the following tests :

1. Check the continuity of the filament and the absence of short-circuits between electrodes.
2. After having removed the ceramic protector, install the tube using a lifting device avoiding shocks.
3. For Hypervapotron® cooled tubes, make sure the cooling water flows in the right direction.
4. Apply the « blackheating » voltage for at least 30 minutes.
5. Apply the nominal heater voltage as specified in the data sheet or following Thomson-CSF special instructions. After 5 minutes, check this voltage at the connector terminals using a true rms voltmeter (ferromagnetic, thermal or digital).
6. Leave the heater voltage on for at least 30 minutes and then apply the other voltages.
7. Gradually increase the output power level to carrier conditions.
8. Gradually apply modulation.

Tube - support assembly in its container.
Remove bindings A and B.

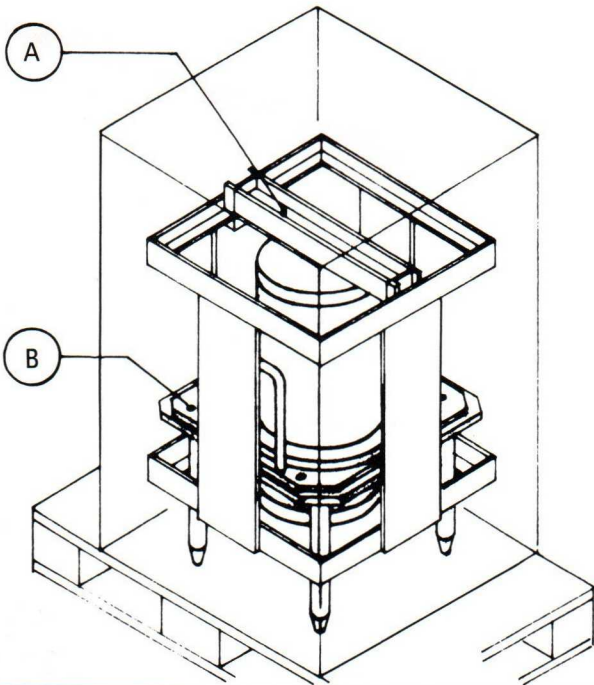

Put lifting device in place and remove the assembly

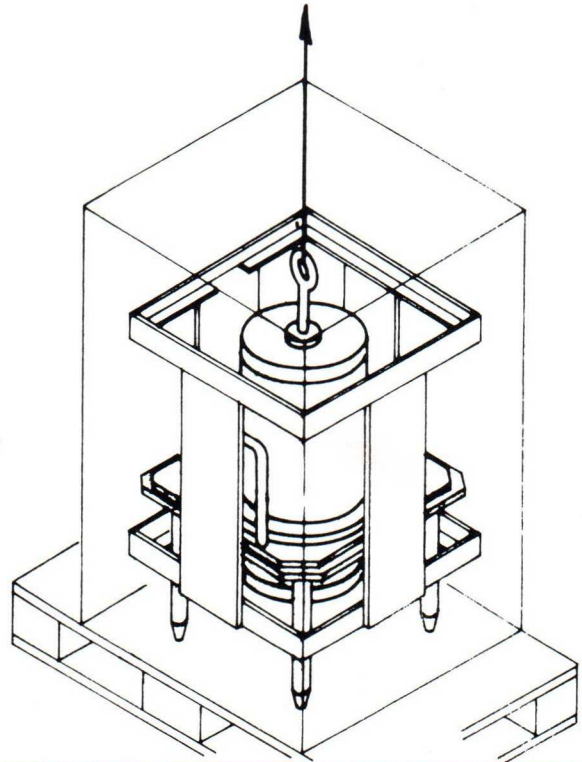

Put the assembly down

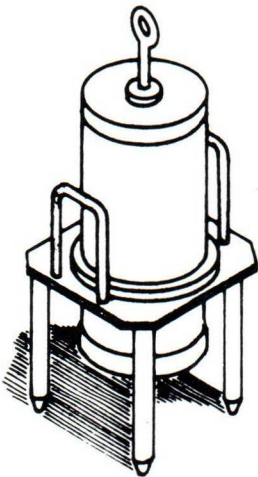

Transport

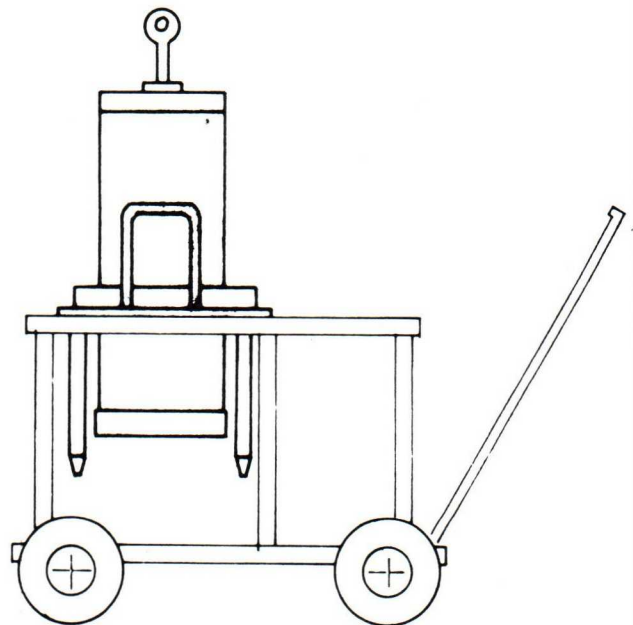
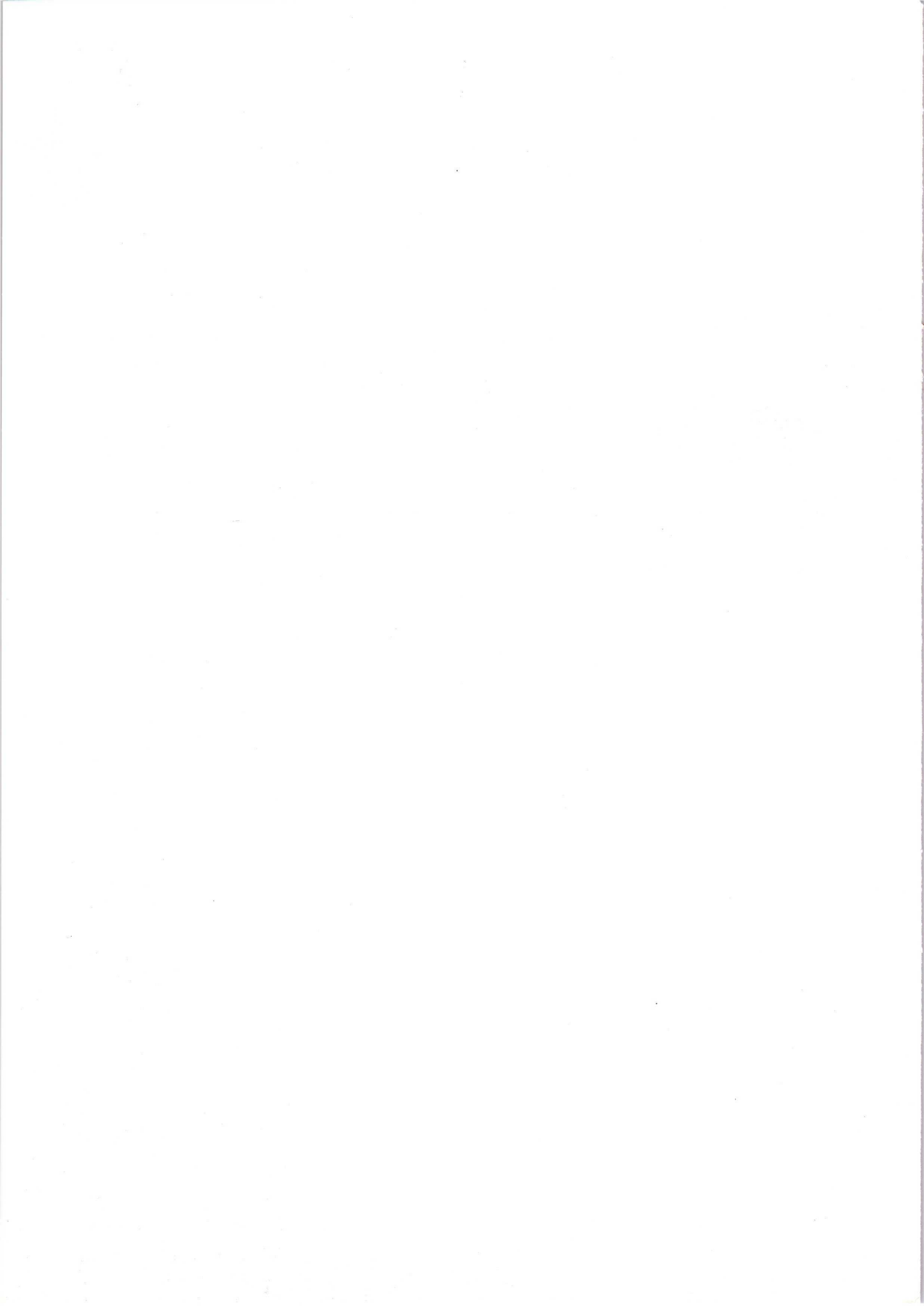

Figure 16 - Handling of a Thomson-CSF high power grid tube.

PART TWO

The second part of this catalogue summarizes the data sheets of Thomson-CSF Radiobroadcasting tubes and gives the main characteristics necessary to end users and manufacturers for the choice of a tube.

Further information and detailed data sheets are available on request from Thomson-CSF Electron Tube Division or your local representative.



INFORMATION & DEFINITIONS

MEASUREMENT CONDITIONS

I - GENERAL CHARACTERISTICS

1. Nominal Heater Voltage

Thomson-CSF defines the nominal heater voltage according to each particular situation. See Part One, paragraph V : « OPERATING INFORMATION AND RECOMMENDATIONS » (page 14 to 17).

2. Heating Current

The data sheets indicate an approximate value for the heating current. This value is modified in the presence of cathode heating from other sources. The approximate values of heater voltage and heating current given on the data sheet may be used in the design of the heater transformer.

3. Interelectrode Capacitances

The interelectrode capacitances have been measured in the factory with a specially designed apparatus free of stray couplings.

4. Minimal Water Flow

The minimal water flow corresponds to the maximum anode dissipation for a typical water temperature at the inlet of 55 °C, and at the outlet of 90 °C. Other values are possible provided that the water outlet-temperature does not exceed 100 °C under atmospheric pressure.

5. Minimal Air Flow

The air flow is designed under the standard conditions of sea level and ambient temperature of 25 °C. In case of anode cooling, the minimum air flow indicated corresponds to the maximum anode dissipation.

6. Maximum Temperatures

The maximum temperatures indicated must not be exceeded at any point in the tube : terminal, ceramics, ceramic-metal seals.

II - MAXIMUM RATINGS

The data sheet indicates the maximum ratings of the various parameters (voltage, current, power, frequency) in general for RF telephony. These ratings must never be exceeded.

Two maximum ratings must never be reached simultaneously.

Peak Cathode Current

Maximum instantaneous current that the cathode can deliver.

Dissipation

Power transformed into heat in an electrode either by electron bombardment or radiation from

other electrodes. This rating depends on the operating conditions.

- In carrier conditions :

The dissipation of the anode corresponds to the difference between the power applied to the anode and the RF output power (neglecting losses). The power dissipated on the screen grid corresponds to the product of the screen dc voltage and dc current. The power dissipated on the control grid corresponds approximately to the product of the grid dc current and peak voltage (using the cathode voltage as a reference).

- In modulation conditions :

The power dissipated on the electrodes depends on the modulation level.

III - TYPICAL OPERATION

The example given in the data sheet shows a trade-off between the parameters : voltage, current, power, frequency and resulting tube performance.

Other examples can be calculated provided that the parameters do not exceed the maximum ratings.

Drive Power

The drive power in a grounded-cathode circuit is equal to the sum of the power dissipated on the control grid and the power supplied to the bias.

Intermodulation Distortion

It is produced by the combination of two signals applied to the amplifier at 1100 Hz and 2450 Hz from the carrier frequency. Their output is set at - 6 dB taking the peak power as the 0 dB reference level.

The level of the intermodulation distortion is then measured with respect to the peak power.

Table II - Power grid tubes for radiobroadcasting

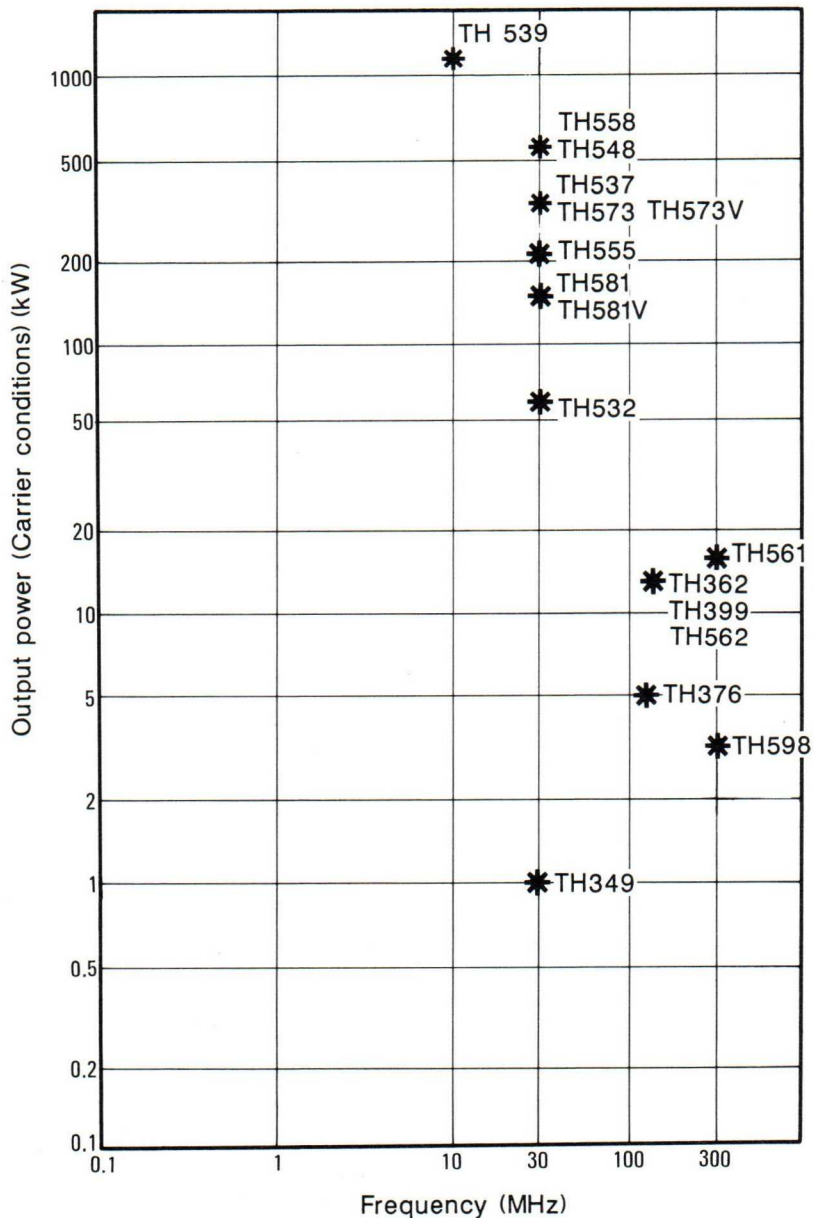

Table III — Product Selection Guide of Power Grid Tubes for Radiobroadcasting

a - Tubes for RF and AF amplification and for PDM¹

	Transmitter	Amplifier			PDM
		driver ²	RF final stage	AF	
HYPERVAPOTRON[®]	1000 kW LW MW	TH 362/TH 561 TH 562	TH 539	2 x TH 558	
	600 kW LW 500 kW MW SW	TH 362/TH 561 TH 562	TH 558	2 x TH 555	TH 558
	300 kW LW 250 kW MW SW	TH 362/TH 561 TH 562	TH 537 or TH 573	2 x TH 581 or 2 x TH 583	TH 573
	100 kW MW SW	TH 598	TH 581 TH 581/TH 555	2 x TH 532	TH 581 TH 581/TH 555
SUPER-[®] VAPOTRON	500 kW LW MW	TH 362 TH 562	TH 548	2 x TH 548	
	300 kW LW MW	TH 362 TH 562	TH 573V	2 x TH 581V	

¹ PDM = Pulse Duration Modulation

² The choice of the tube depends on the preferred anode cooling method (forced air or Hypervapotron[®])

b - Tubes for SSB amplification

Transmitter Power	Amplifier Tube
10 kW	TH 399
5 kW	TH 376
1 kW	TH 349

TH 349 TETRODE

- Output power : 1 kW in SSB
- Operating frequency : up to 110 MHz
- High gain
- Linear characteristics
- Maximum anode dissipation 1.5 kW with forced-air cooling



GENERAL CHARACTERISTICS

Electrical

Type of cathode	Oxide
Heating	Indirect
Heater voltage	Note (1)
Heating current, approx. (2)	10.5 A
Interelectrode capacitances:	
- input	75 pF
- reaction	0.06 pF
- output	14.5 pF
Amplification factor, average	4.5
Transconductance ($I_a = 0.3$ A, $V_{g2} = 225$ V)	25 mA/V

(1) Thomson-CSF defines the operating heater voltage according to each particular situation. See paragraph V: "OPERATING INFORMATION AND RECOMMENDATIONS".

(2) The indicated heating current corresponds to a heater voltage of 6 V. Both values are only approximate, allowing to choose the heater power supply.

Mechanical

Operating position	Vertical
Weight, approx.	840 g
Dimensions	See the Outline Drawing

Anode Cooling

Type	Forced air
Minimum air flow	1.5 m ³ /min
Corresponding air pressure at the input of the TH 16054 connector	2 mbar
Maximum outlet-air temperature	100 °C

Electrode Terminal Cooling

Type	Forced air
Maximum temperature on the tube (ceramic seals and electrode terminals)	250 °C

RF AMPLIFIER OPERATION
(Maximum frequency 30 MHz)

Maximum Ratings

Anode voltage (dc)	3 kV
Control grid voltage (dc)	- 150 V
Screen grid voltage (dc)	400 V
Cathodic current, average	0,9 A
Anode dissipation	1,5 kW
Control grid dissipation	1 W
Screen grid dissipation	12 W

(3) Without taking circuit losses into account.
(4) For a zero-signal anode current of 225 mA.

Typical Operation (in SSB, carrier conditions)

Output power (3)	1 kW
Frequency	30 MHz
Direct anode voltage	2,75 kV
Direct anode current	700 mA
Direct control grid voltage (4)	- 36 V
Direct control grid current	1 mA
Direct screen grid voltage	225 V
Direct screen grid current	20 mA
Drive power	< 1,5 W
Intermodulation ratio	< - 46 dB

ACCESSORY

Connector TH 16054

CONSTANT CURRENT CHARACTERISTICS

$V_{g2} = 225 \text{ V}$

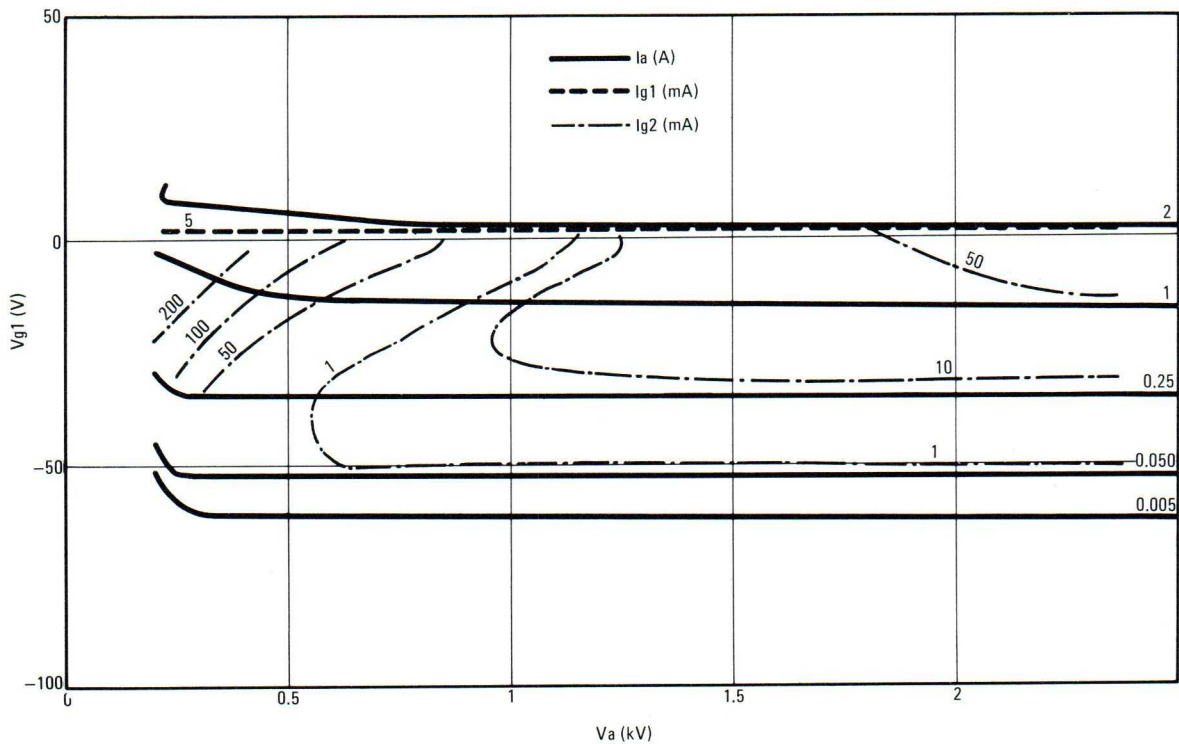

TH 362 TETRODE WITH PYROBLOC[®] GRIDS

- Output power : 12 kW
- Operating frequency up to 120 MHz
- High gain
- High operation stability thanks to the Pyrobloc[®] grids
- Maximum anode dissipation 12 kW with forced-air cooling



GENERAL CHARACTERISTICS

Electrical

Type of cathode	Thoriated tungsten
Heating	Direct, continuous or alternative
Heater voltage	Note (1)
Heating current, approx. (2)	140 A
Interelectrode capacitances, approx. :	
- cathode - control grid	72 pF
- control grid - screen grid	92 pF
- control grid - anode	0.8 pF
- screen grid - anode	16 pF
Amplification factor, average	5.5
Transconductance ($I_{a_1} = 2$ A, V _{g2} = 500 V)	60mA/V

(1) Thomson-CSF defines the operating heater voltage according to each particular situation. See paragraph V: "OPERATING INFORMATION AND RECOMMENDATIONS".

(2) The indicated heating current corresponds to a heater voltage of 7 V. Both values are only approximate, allowing to choose the heater power supply.

Mechanical

Operating position	Vertical
Weight, approx.	7.5 kg
Dimensions	See the Outline Drawing

Anode Cooling

Type	Forced air
Maximum anode dissipation, continuous ...	12 kW
Minimum air flow on the anode	13 m ³ /min
Corresponding pressure drop	note (3)
Maximum air temperature at the output ...	100 °C

Electrode Terminal Cooling

Type	Forced air
Maximum temperature on the tube (ceramic seals and electrode terminals)	250 °C

RF AMPLIFIER OPERATION

Absolute Ratings

Frequency	120 MHz
Anode voltage (dc)	8 kV
Control grid voltage (dc)	- 200 V
Screen grid voltage (dc)	800 V
Peak cathode current	40 A
Anode dissipation	12 kW
Control grid dissipation	100 W
Screen grid dissipation	250 W

Typical Operation (carrier conditions)

Output power (4)	12 kW
Frequency	30 MHz
Anode voltage (dc)	7.5 kV
Anode direct current	2.3 A
Control grid voltage (dc)	- 110 V
Control grid direct current	10 mA
Screen grid voltage (dc)	500 V
Screen grid direct current	100 mA

(3) The pressure drop depends on the chosen connector type.
 (4) Without taking circuit losses into account.

CONSTANT CURRENT CHARACTERISTICS

$V_{g2} = 500 \text{ V}$

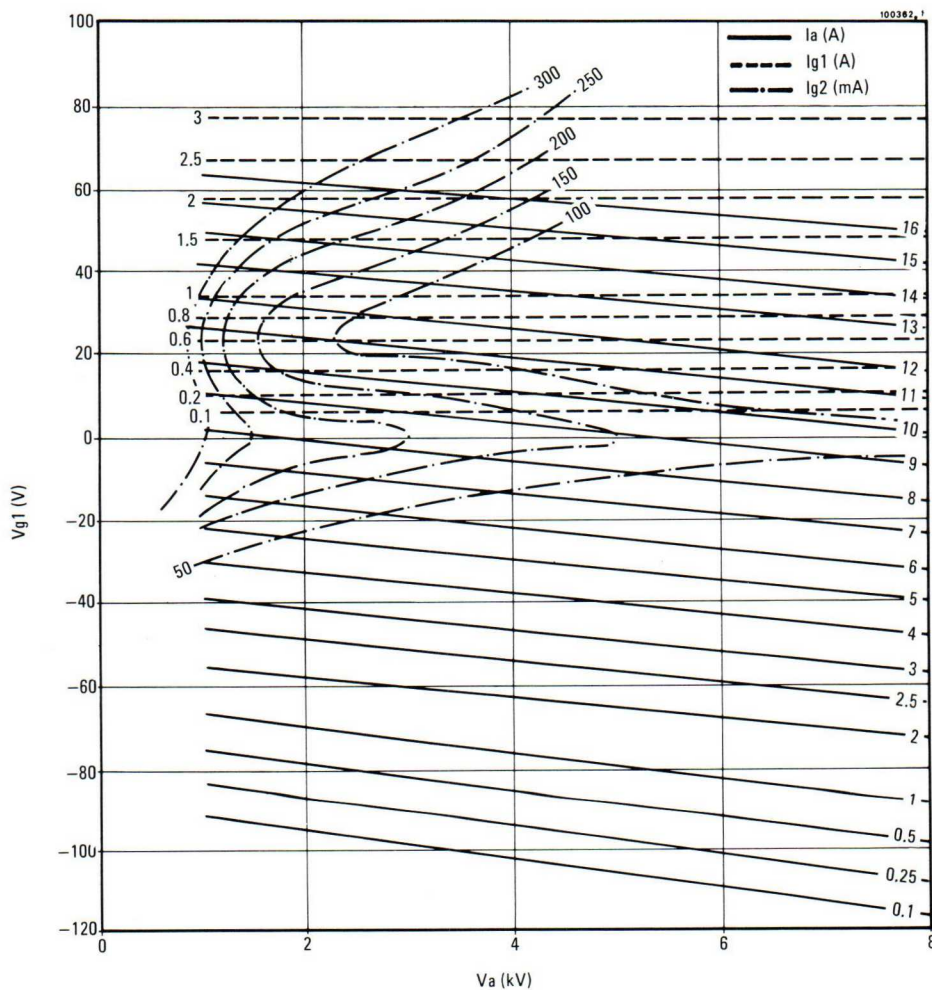

TH 376 TETRODE WITH PYROBLOC[®] GRIDS

- Output power : 5 kW in SSB
- Operating frequency up to 120 MHz
- High gain
- Linear characteristics
- High operation stability thanks to the Pyrobloc[®] grids
- Maximum anode dissipation 5 kW with forced-air cooling



GENERAL CHARACTERISTICS

Electrical

Type of cathode	Thoriated tungsten
Heating	Direct, dc or single-phase ac
Heater voltage	Note (1)
Heating current, approx. (2)	50 A
Interelectrode capacitances (K at ground) :	
- input	115 pF
- reaction	0.4 pF
- output	12 pF
Amplification factor, average	7
Transconductance ($I_a = 1,5$ A, $V_{g2} = 600$ V)	40 mA/V

(1) Thomson-CSF defines the operating heater voltage according to each particular situation. See paragraph V: "OPERATING INFORMATION AND RECOMMENDATIONS".

(2) The indicated heating current corresponds to a heater voltage of 6 V. Both values are only approximate, allowing to choose the heater power supply.

Mechanical

Operating position	Vertical
Weight, approx.	2 kg
Dimensions	See the Outline Drawing

Anode Cooling

Type	Forced air
Minimum air flow on the anode	5 m ³ /min
Corresponding pressure drop at the input of the connector TH 16121	9 mbar
Maximum air temperature at the output ...	100 °C

Electrode Terminal Cooling

Type	Forced air
Maximum temperature on the tube (ceramic seals and electrode terminals)	250 °C

RF AMPLIFIER OPERATION

Absolute Ratings

Frequency	120 MHz
Anode voltage (dc)	6.5 kV
Control grid voltage (dc)	- 200 V
Screen grid voltage (dc)	900 V
Peak cathode current	10 A
Anode dissipation	5 kW
Control grid dissipation	40 W
Screen grid dissipation	60 W

Typical Operation (in SSB, carrier conditions)

Output power (3)	5 kW
Frequency	30 MHz
Anode voltage (dc)	6 kV
Anode direct current	1.5 A
Control grid voltage (dc) (4)	- 110 V
Control grid direct current	0 A
Screen grid voltage (dc)	800 V
Screen grid direct current	40 mA
Drive power	15 W
Intermodulation ratio	< - 44 dB

(3) Without taking circuit losses into account.
 (4) For a zero-signal anode current of 0.7 A.

ACCESSORY

Connector (for SSB equipment) TH 16121

CONSTANT CURRENT CHARACTERISTICS

$V_{g2} = 800 \text{ V}$

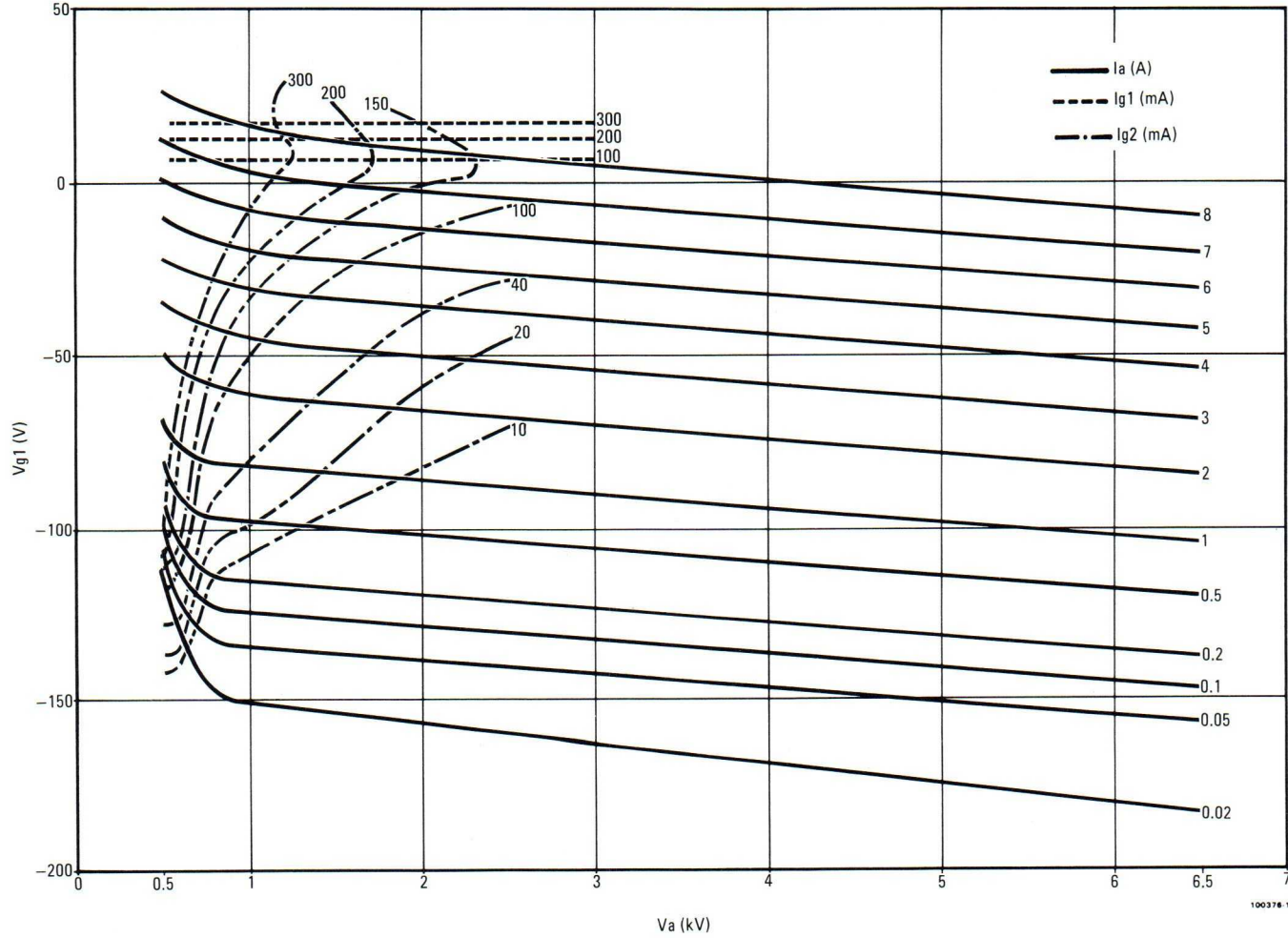

TH 399 TETRODE WITH PYROBLOC[®] GRIDS

- High output power : 12 kW in FM and 10 kW in SSB
- Operating frequency up to 120 MHz
- High gain
- Linear characteristics
- High operation stability thanks to the Pyrobloc[®] grids
- Maximum anode dissipation 12 kW with forced-air cooling



GENERAL CHARACTERISTICS

Electrical

Type of cathode	Thoriated tungsten
Heating	Direct, dc or single-phase ac
Heater voltage	Note (1)
Heating current, approx. (2)	140 A
Interelectrode capacitances (K at ground) :	
- input	218 pF
- reaction	0.8 pF
- output	17 pF
Amplification factor, average	5.5
Transconductance ($I_a = 2$ A, Vg2 = 500 V)	60 mA/V

(1) Thomson-CSF defines the operating heater voltage according to each particular situation. See paragraph V: "OPERATING INFORMATION AND RECOMMENDATIONS".

(2) The indicated heating current corresponds to a heater voltage of 7 V. Both values are only approximate, allowing to choose the heater power supply.

Mechanical

Operating position	Vertical
Weight, approx.	7.5 kg
Dimensions	See the Outline Drawing

Anode Cooling

Type	Forced air
Minimum air flow on the anode	13 m ³ /min
Corresponding pressure drop at the input of the connector TH 16116	9 mbar
Maximum outlet-air temperature	100 °C

Electrode Terminal Cooling

Type	Forced air
Maximum temperature on the tube (ceramic seals and electrode terminals)	250 °C

RF AMPLIFIER OPERATION

Absolute Ratings

Frequency	120 MHz
Anode voltage (dc)	8 kV
Control grid voltage (dc)	- 200 V
Screen grid voltage (dc)	800 V
Peak cathode current	40 A
Anode dissipation	12 kW
Control grid dissipation	100 W
Screen grid dissipation	250 W

(3) Without taking circuit losses into account.
 (4) For a zero-signal anode current of 1.2 A.

Typical Operation (in SSB, carrier conditions)

Output power (3)	10 kW
Frequency	30 MHz
Anode voltage (dc)	7.2 kV
Anode direct current	2.4 A
Control grid voltage (dc) (4)	- 100 V
Control grid direct current	0 mA
Screen grid voltage (dc)	600 V
Screen grid direct current	30 mA
Drive power	< 30 W
Intermodulation ratio	< 44 dB

ACCESSORY

Connector (for SSB equipment) TH 16116

CONSTANT CURRENT CHARACTERISTICS

$V_{g2} = 600 \text{ V}$

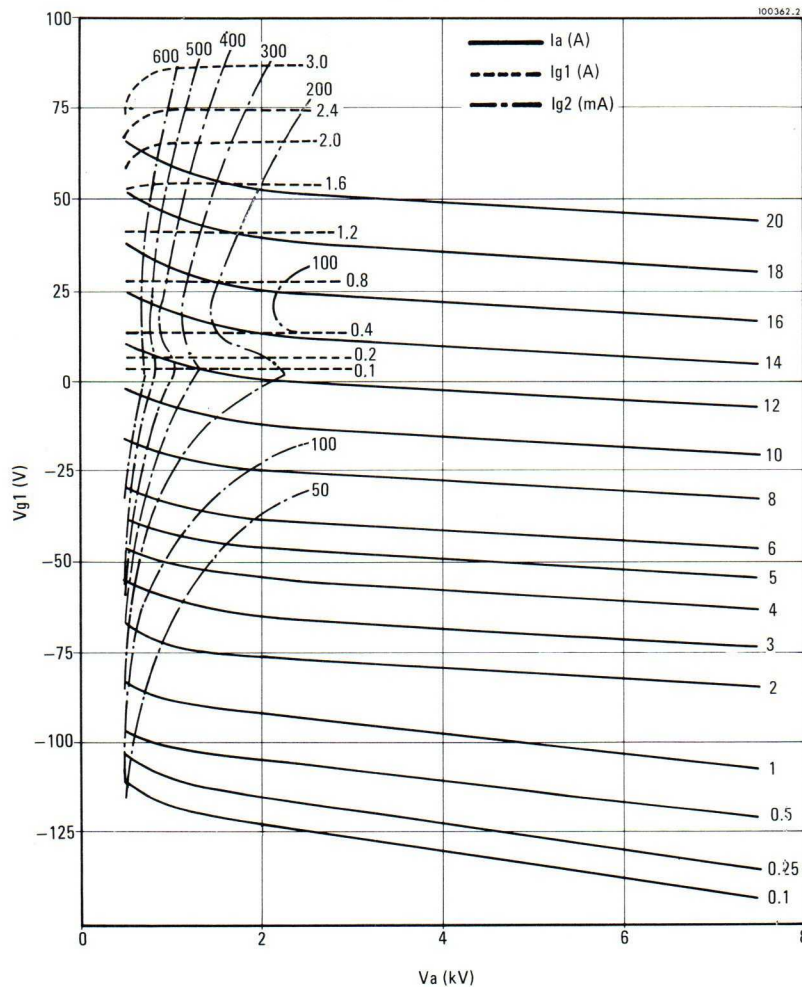

TH 532 HYPERVAPOTRON[®] TETRODE WITH PYROBLOC[®] GRIDS

- Output power : 60 kW in MW and SW
- Operating frequency up to 110 MHz
- High gain
- High operation stability thanks to the Pyrobloc[®] grids
- Maximum anode dissipation 60 kW with Hypervapotron[®] cooling



GENERAL CHARACTERISTICS

Electrical

Type of cathode	Thoriated tungsten
Heating	Direct, dc or single-phase ac
Heater voltage	Note (1)
Heating current, approx. (2)	200 A
Interelectrode capacitances, approx. :	
- cathode - control grid	140 pF
- control grid - screen grid	265 pF
- control grid - anode	1.4 pF
- screen grid - anode	35 pF
Amplification factor, average	4.8
Transconductance (I _a = 4 A)	80 mA/V

(1) Thomson-CSF defines the operating heater voltage according to each particular situation. See paragraph V : "OPERATING INFORMATION AND RECOMMENDATIONS".

(2) The indicated heating current corresponds to a heater voltage of 10 V. Both values are only approximate, allowing to choose the heater power supply.

Mechanical

Operating position	Vertical, anode up
Weight, approx.	17 kg
Dimensions	See the Outline Drawing

Anode Cooling

Type	Hypervapotron
Maximum anode dissipation, continuous ...	60 kW
Minimum corresponding water flow	25 l/min
Maximum water pressure at the input	5 bar
Maximum water temperature at the output	100 °C

Electrode Terminal Cooling

Type	Forced air
Cooling with TH 16118 connector :	
- minimum flow	1 m ³ /min
- corresponding pressure drop	12 mbar
Maximum temperature on the tube (ceramic seals and electrode terminals)	200 °C

RF AMPLIFIER OPERATION (Telephony, maximum frequency 30 MHz)

Absolute Ratings

Anode voltage (dc)	12 kV
Control grid voltage (dc)	— 500 V
Screen grid voltage (dc)	900 V
Peak cathode current	70 A
Anode dissipation	60 kW
Control grid dissipation	300 W
Screen grid dissipation	600 W

Typical Operation (carrier conditions)

Output power (3)	55 kW
Frequency	30 MHz
Anode voltage (dc)	11 kV
Anode direct current	7.5 A
Control grid voltage (dc)	— 300 V
Control grid direct current	0.39 A
Screen grid voltage (dc)	700 V
Screen grid direct current	0.15 A
Anode dissipation	27.5 kW
Control grid dissipation	50 W
Screen grid dissipation	105 W

(3) Without taking circuit losses into account.

ACCESSORIES

Connector	TH 16118
Flexible insulating tubing	TH 17316
Antielectrolytic coupling	TH 17400
Self-obturating coupling	TH 17414
Lifting device	TH 14218

CONSTANT CURRENT CHARACTERISTICS

$V_{g2} = 1000 \text{ V}$

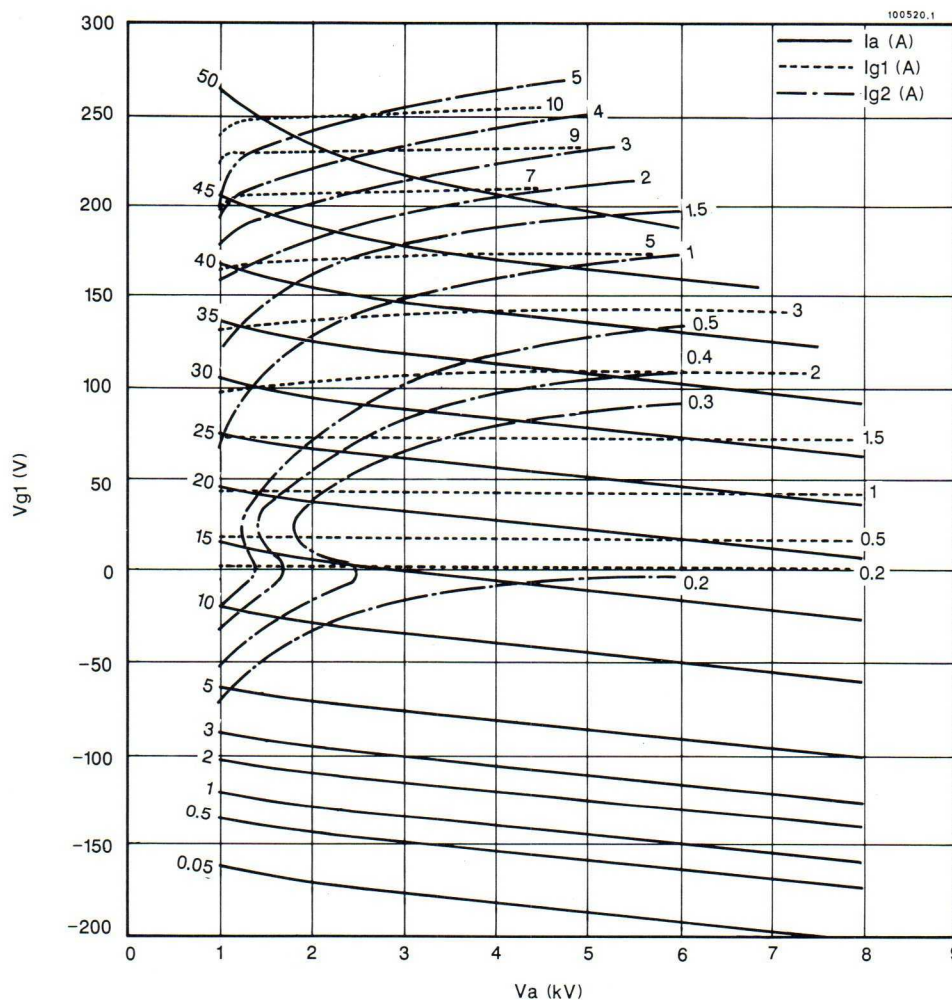

TH 537 HYPERVAPOTRON[®] TETRODE WITH PYROBLOC[®] GRIDS

- Output power :
 - 350 kW in LW and MW
 - 300 kW in SW
- Operating frequency up to 110 MHz
- High gain
- High operation stability thanks to the Pyrobloc[®] grids
- Maximum anode dissipation 300 kW with Hypervapotron[®] cooling



GENERAL CHARACTERISTICS

Electrical

Type of cathode Thoriated tungsten
 Heating Direct, dc or single-phase ac
 Heater voltage Note (1)
 Heating current, approx. (2) 430 A
 Interelectrode capacitances, approx. :
 - cathode - control grid 310 pF
 - control grid - screen grid 510 pF
 - control grid - anode 4.5 pF
 - screen grid - anode 74 pF
 Amplification factor, average 4.3
 Transconductance ($I_a = 25$ A,
 $V_{g2} = 1000$ V) 400 mA/V

(1) Thomson-CSF defines the operating heater voltage according to each particular situation. See paragraph V : "OPERATING INFORMATION AND RECOMMENDATIONS".

(2) The indicated heating current corresponds to a heater voltage of 18 V. Both values are only approximate, allowing to choose the heater power supply.

Mechanical

Operating position Vertical, anode up
 Weight, approx. 56 kg
 Dimensions See the Outline Drawing

Anode Cooling

Type Hypervapotron
 Maximum anode dissipation, continuous .. 300 kW
 Minimum corresponding water flow 150 l/min
 Maximum water pressure at the input
 of the cooler 5 bar
 Maximum water temperature at the output 100 °C

Electrode Terminal Cooling

Type Forced air
 Cooling with TH 16108A connector :
 - minimum flow 1.5 m³/min
 - corresponding pressure drop 15 mbar
 Maximum temperature on the tube (ceramic
 seals and electrode terminals) 200 °C

RF AMPLIFIER OPERATION (Telephony, maximum frequency 30 MHz)

Absolute Ratings

Anode voltage (dc)	12 kV
Control grid voltage (dc)	— 800 V
Screen grid voltage (dc)	1200 V
Peak cathode current	400 A
Anode dissipation	300 kW
Control grid dissipation	2 kW
Screen grid dissipation	5 kW

(3) Without taking circuit losses into account.

Typical Operation (carrier conditions)

Output power (3)	305 kW
Frequency	30 MHz
Anode voltage (dc)	11 kV
Anode direct current	36 A
Control grid voltage (dc)	— 550 V
Control grid direct current	2 A
Screen grid voltage (dc)	1000 V
Screen grid direct current	1.3 A
Anode dissipation	91 kW
Control grid dissipation	300 W
Screen grid dissipation	1.3 kW

ACCESSORIES

Connector	TH 16108A
Flexible insulating tubing	TH 17317
Antielectrolytic coupling	TH 17399
Self-obturating coupling	TH 17415B
Lifting device	TH 14218

CONSTANT CURRENT CHARACTERISTICS

$V_{g2} = 1000 \text{ V}$

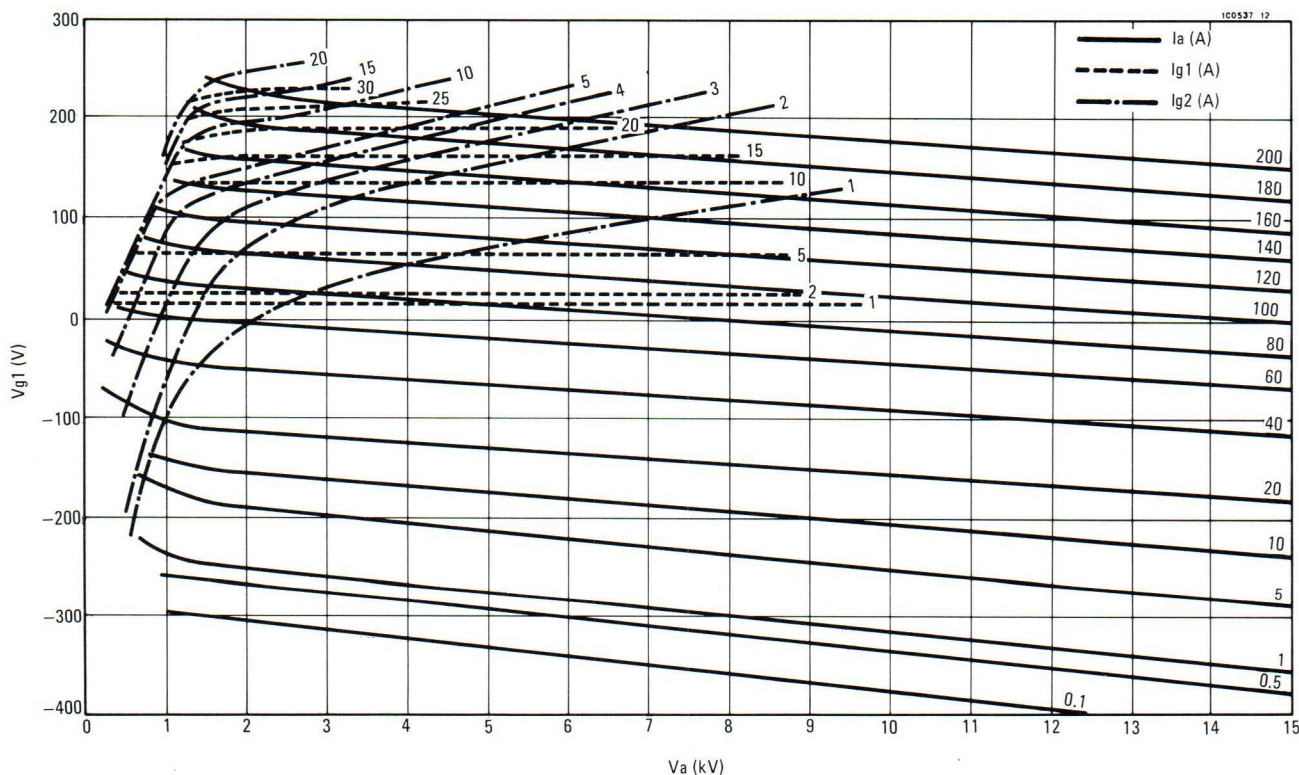

TH 539 HYPERVAPOTRON[®] TETRODE WITH PYROBLOC[®] GRIDS

- Output power : 1,25 MW in LW and MW
- Operating frequency : up to 50 MHz
- High gain
- High operation stability thanks to Pyrobloc[®] grids
- Maximum anode dissipation 1 MW with Hypervapotron[®] cooling



GENERAL CHARACTERISTICS

Electrical

Type of cathode Thoriated tungsten
 Heating Direct, dc or single-phase ac
 Heater voltage Note (1)
 Heating current, approx. (2) 900 A
 Interelectrode capacitances, approx. :
 - cathode - control grid 830 pF
 - control grid - screen grid 1550 pF
 - control grid - anode 15,5 pF
 - screen grid - anode 220 pF
 Amplification factor, average 5
 Transconductance ($I_a = 35$ A,
 $V_{g2} = 1000$ V) 600 mA/V

(1) Thomson-CSF defines the operating heater voltage according to each particular situation. See paragraph V : "OPERATING INFORMATION AND RECOMMENDATIONS".

(2) The indicated heating current corresponds to a heater voltage of 30 V. Both values are only approximate, allowing to choose the heater power supply.

Mechanical

Operating position Vertical, anode up
 Weight, approx. 155 kg
 Dimensions See the Outline Drawing

Anode Cooling

Type Hypervapotron
 Maximum anode dissipation 1 MW
 Minimum water flow 400 l/min
 Maximum water pressure at the
 input of the cooler 5 bar
 Maximum water temperature at
 the output 100 °C

Electrode Terminal Cooling

Type Forced air
 Cooling with TH 16114 connector :
 - minimum flow 5 m³/min
 - corresponding pressure drop 20 mbar
 Maximum temperature on the envelope
 of the tube (ceramic seals and
 electrode terminals) 200 °C

RF AMPLIFIER OPERATION (Telephony, maximum frequency 30 MHz)

Maximum Ratings

Anode voltage (dc)	13,5 kV
Control grid voltage (dc)	— 800 V
Screen grid voltage (dc)	1250 V
Peak cathode current	1300 A
Anode dissipation	1 MW
Control grid dissipation	6 kW
Screen grid dissipation	16kW

(3) Without taking circuit losses into account.

Typical Operation (carrier conditions)

Output power (3)	1170 kW
Frequency	2 MHz
Anode voltage (dc)	13,0 kV
Anode direct current	110 A
Control grid voltage (dc)	— 700 V
Control grid direct current	5 A
Screen grid voltage (dc)	1100 V
Screen grid direct current	5 A
Anode dissipation	260 kW
Control grid dissipation	1 kW
Screen grid dissipation	5,5 kW

ACCESSORIES

Connector	TH 16114
Flexible insulating tubing	TH 17319
Antielectrolytic coupling	TH 17397
Self-obturing coupling	TH 17416B
Lifting device	TH 14226

CONSTANT CURRENT CHARACTERISTICS

$V_{g2} = 1000 \text{ V}$

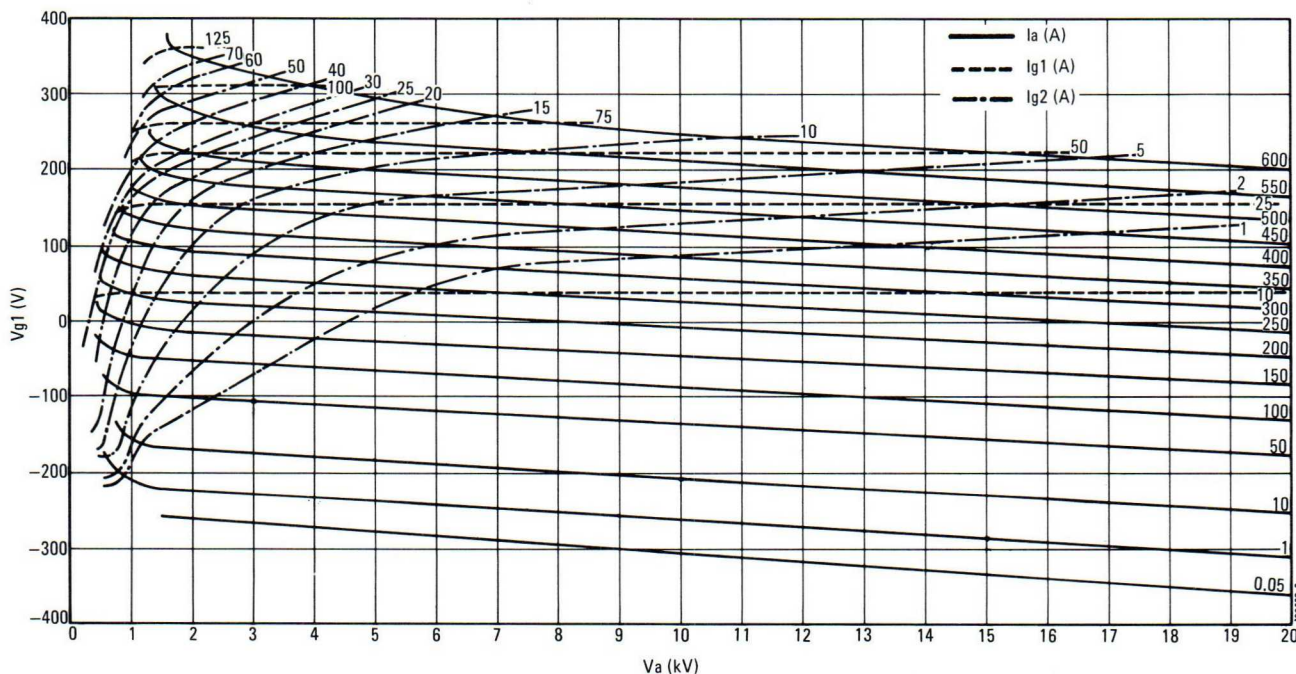

TH 548 SUPERVAPOTRON[®] TETRODE WITH PYROBLOC[®] GRIDS

- Output power : 520 kW in LW and MW
- Operating frequency up to 30 MHz
- High gain
- High operation stability thanks to the Pyrobloc[®] grids
- Maximum anode dissipation 250 kW with Supervapotron[®] cooling



GENERAL CHARACTERISTICS

Electrical

Type of cathode Thoriated tungsten
 Heating Direct, dc or single-phase ac
 Heater voltage Note (1)
 Heating current, approx. (2) 500 A
 Interelectrode capacitances, approx. :
 - cathode - control grid 445 pF
 - control grid - screen grid 750 pF
 - anode - cathode 6.3 pF
 - screen grid - anode 100 pF
 Amplification factor, average 4.4
 Transconductance ($I_a = 35$ A,
 $V_{g2} = 1000$ V) 500 mA/V

(1) Thomson-CSF defines the operating heater voltage according to each particular situation. See paragraph V: "OPERATING INFORMATION AND RECOMMENDATIONS".

(2) The indicated heating current corresponds to a heater voltage of 23 V. Both values are only approximate, allowing to choose the heater power supply.

Mechanical

Operating position Vertical
 Weight, approx. (without boiler) 68 kg
 Dimensions See the Outline Drawing

Anode Cooling

Type Supervapotron
 Maximum anode dissipation 250 kW

Electrode Terminal Cooling

Type Forced air
 Cooling with TH 16107A :
 - minimum flow 1.6 m³/min
 - corresponding pressure drop 18 mbar
 Maximum temperature on the tube (ceramic
 seals and electrode terminals) 200 °C

RF AMPLIFIER OPERATION - TELEPHONY

Absolute Ratings

Frequency	30 MHz
Anode voltage (dc)	13 kV
Control grid voltage (dc)	- 800 V
Screen grid voltage (dc)	1250 V
Peak cathode current	600 A
Anode dissipation	250 kW
Control grid dissipation	3 kW
Screen grid dissipation	8 kW

(3) Without taking circuit losses into account.

Typical Operation (carrier conditions)

Output power (3)	520 kW
Frequency	2 MHz
Anode voltage (dc)	12 kV
Anode direct current	54 A
Control grid voltage (dc)	- 600 V
Control grid direct current	4 A
Screen grid voltage (dc)	1100 V
Screen grid direct current	2.5 A
Anode dissipation	128 kW
Control grid dissipation	600 W
Screen grid dissipation	2.75 kW

ACCESSORIES

Connector	TH 16107A
Boiler	TH 17028
Toroidal gasket	TH 17819
Vapor outlet pipe	TH 17320
Flexible insulating tubing	TH 17817
Antielectrolytic coupling	TH 17395
Insulating pipe for water inlet	TH 17321
Lifting device	TH 14215

CONSTANT CURRENT CHARACTERISTICS

Vg2 = 1000 V

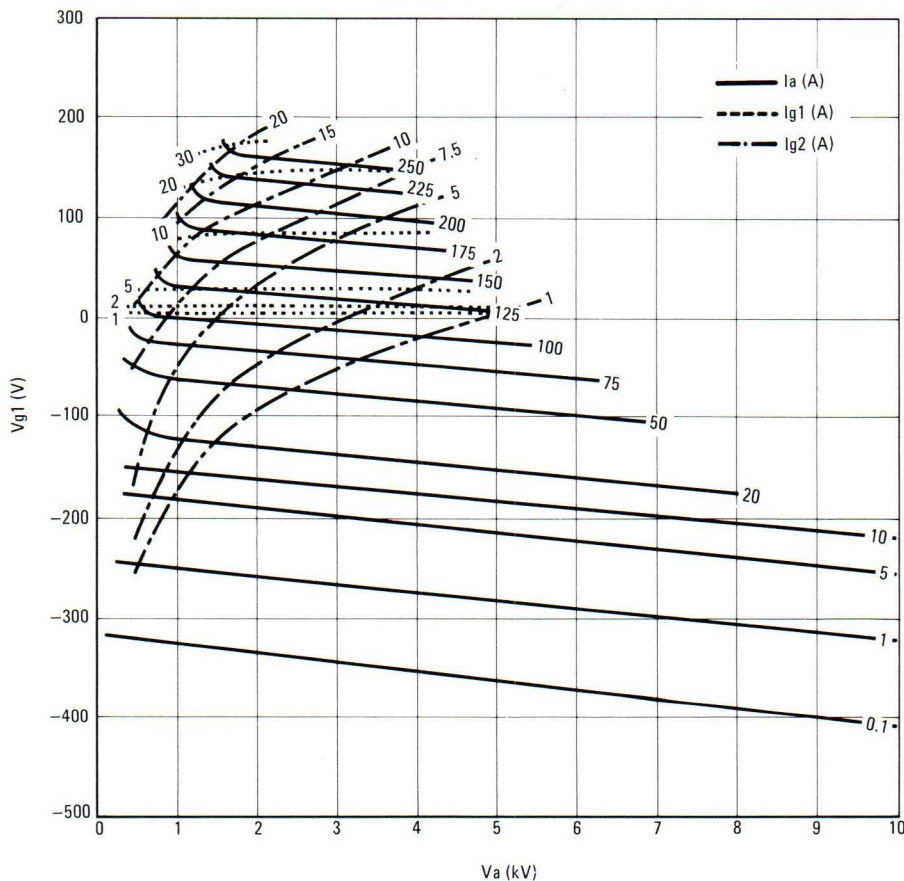

TH 555 HYPERVAPOTRON[®] TETRODE WITH PYROBLOC[®] GRIDS

- Output power :
 - 250 kW in LW and MW
 - 200 kW in SW
- Operating frequency up to 110 MHz
- High gain
- High operation stability thanks to the Pyrobloc[®] grids
- Maximum anode dissipation 250 kW with Hypervapotron[®] cooling



GENERAL CHARACTERISTICS

Electrical

Type of cathode Thoriated tungsten
 Heating Direct, dc or single-phase ac
 Heater voltage Note (1)
 Heating current, approx. (2) 320 A
 Interelectrode capacitances, approx. :

- cathode - control grid 245 pF
- control grid - screen grid 400 pF
- control grid - anode 4 pF
- screen grid - anode 62 pF

Amplification factor, average 4.8
 Transconductance ($I_a = 15$ A,
 $V_{g2} = 1000$ V) 220 mA/V

(1) Thomson-CSF defines the operating heater voltage according to each particular situation. See paragraph V : "OPERATING INFORMATION AND RECOMMENDATIONS".

(2) The indicated heating current corresponds to a heater voltage of 15 V. Both values are only approximate, allowing to choose the heater power supply.

Mechanical

Operating position Vertical, anode up
 Weight, approx. 38 kg
 Dimensions See the Outline Drawing

Anode Cooling

Type Hypervapotron
 Maximum anode dissipation, continuous .. 250 kW
 Minimum corresponding water flow 110 l/min
 Maximum water pressure at the input 5 bar
 Maximum water temperature at the output 100 °C

Electrode Terminal Cooling

Type Forced air
 Cooling with TH 16110 connector :

- minimum flow 1 m³/min
- corresponding pressure drop 12 mbar

Maximum temperature on the tube (ceramic seals and electrode terminals) 200 °C

RF AMPLIFIER OPERATION (Telephony, maximum frequency 30 MHz)

Absolute Ratings

Anode voltage (dc)	12 kV
Control grid voltage (dc)	— 800 V
Screen grid voltage (dc)	1200 V
Peak cathode current	300 A
Anode dissipation	250 kW
Control grid dissipation	1.5 kW
Screen grid dissipation	4 kW

Typical operation (carrier conditions)

Output power (3)	235 kW
Frequency	30 MHz
Anode voltage (dc)	11 kV
Anode direct current	27 A
Control grid voltage (dc)	— 550 V
Control grid direct current	1.8 A
Screen grid voltage (dc)	1000 V
Screen grid direct current	1.1 A
Anode dissipation	62 kW
Control grid dissipation	360 W
Screen grid dissipation	1.1 kW

(3) Without taking circuit losses into account.

ACCESSORIES

Connector	TH 16110
Flexible insulating tubing	TH 17317
Antielectrolytic coupling	TH 17399
Self-obturating coupling	TH 17415B
Lifting device	TH 14218

CONSTANT CURRENT CHARACTERISTICS

$V_{g2} = 1000 \text{ V}$

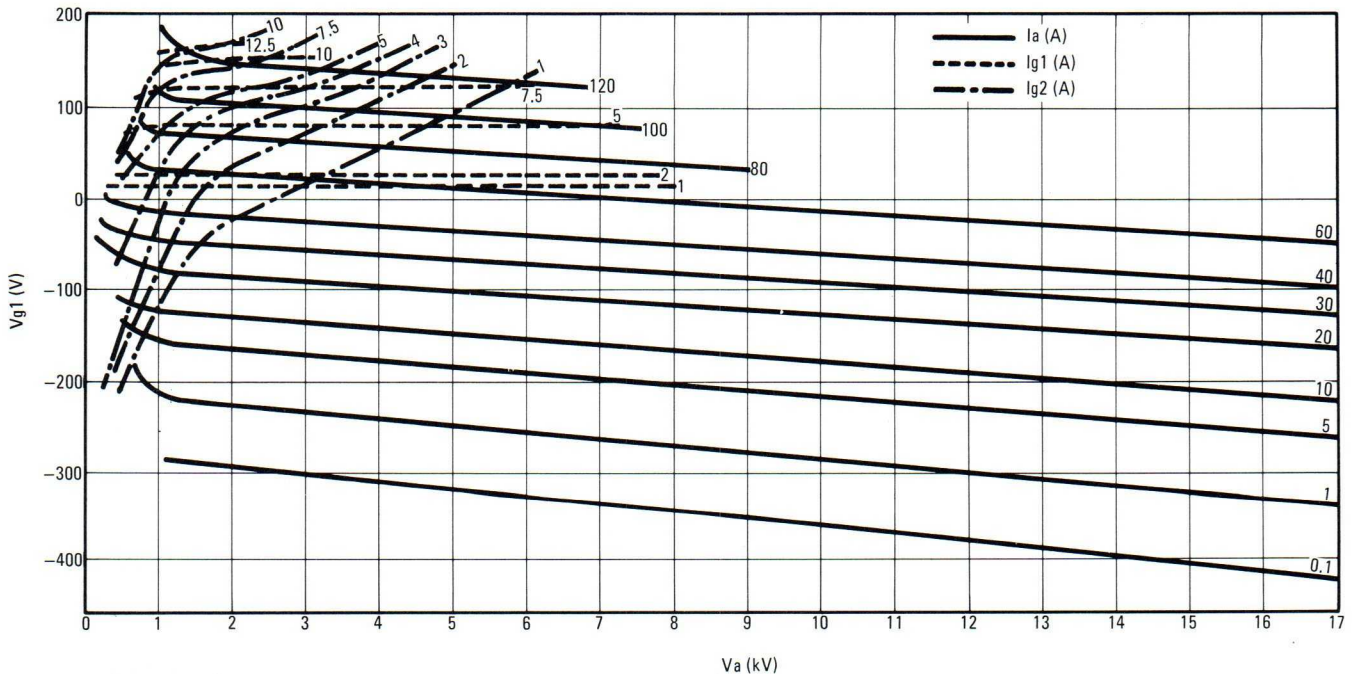

TH 558 HYPERVAPOTRON[®] TETRODE WITH PYROBLOC[®] GRIDS

- **Output power :**
 - 650 kW in LW and MW
 - 550 kW in SW
- **Operating frequency :** up to 110 MHz
- **High gain**
- **High operation stability thanks to Pyrobloc[®] grids**
- **Maximum anode dissipation 500 kW with Hypervapotron[®] cooling**



GENERAL CHARACTERISTICS

Electrical

Type of cathode	Thoriated tungsten
Heating	Direct, dc or single-phase ac
Heater voltage	Note (1)
Heating current, approx. (2)	500 A
Interelectrode capacitances, approx. :	
- cathode - control grid	445 pF
- control grid - screen grid	750 pF
- control grid - anode	6.3 pF
- screen grid - anode	100 pF
Amplification factor, average	4.4
Transconductance (I _a = 35 A, V _{g2} = 1000 V)	500 mA/V

(1) Thomson-CSF defines the operating heater voltage according to each particular situation. See paragraph V: "OPERATING INFORMATION AND RECOMMENDATIONS".

(2) The indicated heating current corresponds to a heater voltage of 23 V. Both values are only approximate, allowing to choose the heater power supply.

Mechanical

Operating position	Vertical, anode up
Weight, approx.	74 kg
Dimensions	See the Outline Drawing

Anode Cooling

Type	Hypervapotron
Maximum anode dissipation	500 kW
Minimum corresponding water flow	200 l/min
Maximum water pressure at the input of the cooler	5 bar
Maximum water temperature at the output	100 °C

Electrode Terminal Cooling

Type	Forced air
Cooling with TH 16124 connector :	
- minimum flow	1.6 m ³ /min
- corresponding pressure drop	18 mbar
Maximum temperature on the envelope of the tube (ceramic seals and electrode terminals) ..	200 °C

RF AMPLIFIER OPERATION (Telephony, maximum frequency 30 MHz)

Maximum Ratings

Anode voltage (dc)	13.5 kV
Control grid voltage (dc)	— 800 V
Screen grid voltage (dc)	1250 V
Peak cathode current	600 A
Anode dissipation	500 kW
Control grid dissipation	3 kW
Screen grid dissipation	8 kW

Typical Operation (carrier conditions)

Output power (3)	550 kW
Frequency	30 MHz
Anode voltage (dc)	12.5 kV
Anode direct current	54 A
Control grid voltage (dc)	— 600 V
Control grid direct current	4 A
Screen grid voltage (dc)	1100 V
Screen grid direct current	2.5 A
Anode dissipation	125 kW
Control grid dissipation	600 W
Screen grid dissipation	2.75 kW

(3) Without taking circuit losses into account.

ACCESSORIES

Connector	TH 16124
Flexible insulating tubing	TH 17319
Antielectrolytic coupling	TH 17397
Self-obturing coupling	TH 17416B
Lifting device	TH 14218

CONSTANT CURRENT CHARACTERISTICS

$V_{g2} = 1000 \text{ V}$

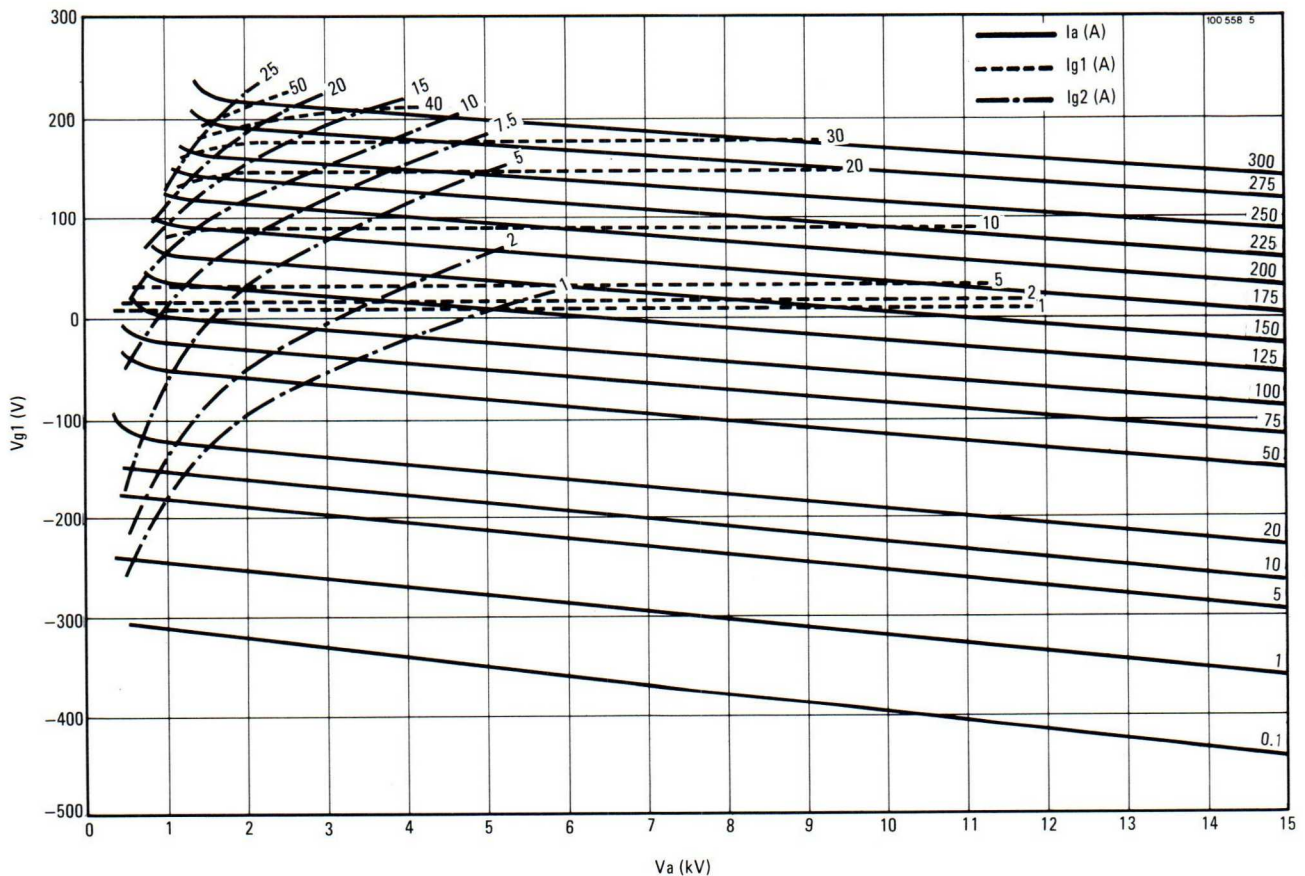

TH 561 HYPERVAPOTRON[®] TETRODE WITH PYROBLOC[®] GRIDS

- Output power : 15 kW
- Operating frequency up to 300 MHz
- High gain
- High operation stability thanks to the Pyrobloc[®] grids
- Maximum anode dissipation 20 kW with Hypervapotron[®] cooling



GENERAL CHARACTERISTICS

Electrical

Type of cathode	Thoriated tungsten
Heating	Direct, dc or single-phase ac
Heater voltage	Note (1)
Heating current, approx. (2)	140 A
Interelectrode capacitances, approx. :	
- cathode - control grid	83 pF
- control grid - screen grid	135 pF
- control grid - anode	0.8 pF
- screen grid - anode	17 pF
Amplification factor, average	5.5
Transconductance ($I_a = 2$ A, $V_{g2} = 500$ V)	60 mA/V

(1) Thomson-CSF defines the operating heater voltage according to each particular situation. See paragraph V: "OPERATING INFORMATION AND RECOMMENDATIONS".

(2) The indicated heating current corresponds to a heater voltage of 7 V. Both values are only approximate, allowing to choose the heater power supply.

Mechanical

Operating position	Vertical
Weight, approx.	4.2 kg
Dimensions	See the Outline Drawing

Anode Cooling

Type	Hypervapotron
Maximum anode dissipation	20 kW
Minimum corresponding water flow	8 l/min
Maximum water pressure at the input of the cooler	5 bar
Maximum water temperature at the output	100 °C

Electrode Terminal Cooling

Type	Forced air
Cooling :	
- minimum flow	0.7 m ³ /min
- corresponding pressure drop	note (3)
Maximum temperature on the tube (ceramic seals and electrode terminals)	250 °C

RF AMPLIFIER OPERATION

Absolute Ratings

Frequency	300 MHz
Anode voltage (dc)	8 kV
Control grid voltage (dc)	- 200 V
Screen grid voltage (dc)	800 V
Peak cathode current	40 A
Anode dissipation	20 kW
Control grid dissipation	100 W
Screen grid dissipation	250 W

Typical Operation (carrier conditions)

Output power (4)	12 kW
Frequency	30 MHz
Anode voltage (dc)	7.5 kV
Anode direct current	2.3 A
Control grid voltage (dc)	- 110 V
Control grid direct current	10 mA
Screen grid voltage (dc)	500 V
Screen grid direct current	100 mA

(3) The pressure drop depends on the type of connector.
 (4) Without taking circuit losses into account.

ACCESSORIES

Flexible insulating tubing	TH 17316
Antielectrolytic coupling (female)	TH 17400
Antielectrolytic coupling (male)	TH 17385
Self-obturing coupling	TH 17414

CONSTANT CURRENT CHARACTERISTICS

Vg2 = 600 V

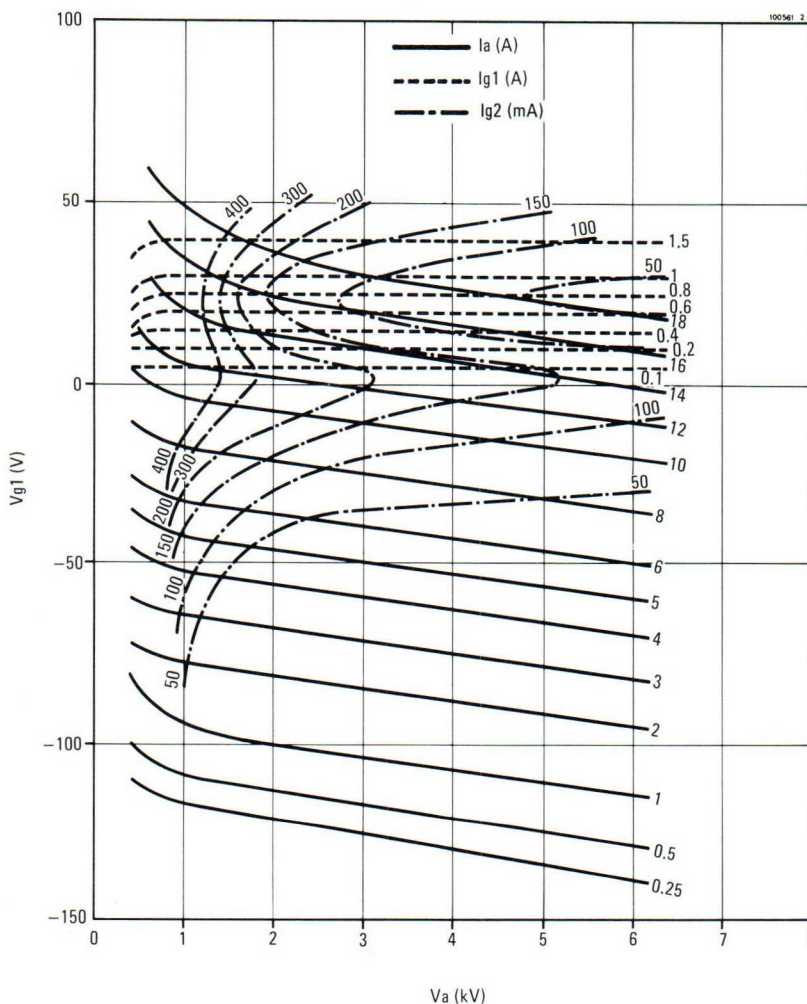

TH 562 HYPERVAPOTRON[®] TETRODE WITH PYROBLOC[®] GRIDS



- Output power : 12 kW
- Operating frequency : up to 120 MHz
- High gain
- High operation stability thanks to Pyrobloc[®] grids
- Maximum anode dissipation 20 kW with Hypervapotron[®] cooling

GENERAL CHARACTERISTICS

Electrical

Type of cathode	Thoriated tungsten
Heating	Direct, dc or single-phase ac
Heater voltage	Note (1)
Heating current, approx. (2)	140 A
Interelectrode capacitances, approx. :	
- cathode - control grid	72 pF
- control grid - screen grid	92 pF
- control grid - anode	0.8 pF
- screen grid - anode	16 pF
Amplification factor, average	5.5
Transconductance ($I_a = 2$ A,	
$V_{g2} = 500$ V)	60 mA/V

(1) Thomson-CSF defines the operating heater voltage according to each particular situation. See paragraph V: "OPERATING INFORMATION AND RECOMMENDATIONS".

(2) The indicated heating current corresponds to a heater voltage of 23 V. Both values are only approximate, allowing to choose the heater power supply.

Mechanical

Operating position	Vertical anode up
Weight, approx.	4,4 kg
Dimensions	See the Outline Drawing

Anode Cooling

Type	Hypervapotron
Maximum anode dissipation	20 kW
Minimum corresponding water flow	12 l/min
Maximum water pressure at the	
input of the cooler	5 bar
Maximum water temperature at the output	100 °C

Electrode Terminal Cooling

Type	Forced air
Cooling with TH 16124 connector :	
- minimum flow	0.7 m ³ /min
- corresponding pressure drop	18 mbar
Maximum temperature on the envelope of the tube	
(ceramic seals and electrode terminals) ..	250 °C

RF AMPLIFIER OPERATION (Telephony, maximum frequency 30 MHz)

Maximum Ratings

Anode voltage (dc)	8 kV
Control grid voltage (dc)	- 200 V
Screen grid voltage (dc)	800 V
Peak cathode current	40 A
Anode dissipation	20 kW
Control grid dissipation	100 kW
Screen grid dissipation	250 kW

Typical Operation (carrier conditions)

Output power (3)	12 kW
Frequency	110 MHz
Anode voltage (dc)	7.5 kV
Anode direct current	2.3 A
Control grid voltage (dc)	- 110 V
Control grid direct current	10 mA
Screen grid voltage (dc)	500 V
Screen grid direct current	100 mA

(3) Without taking circuit losses into account.

ACCESSORIES

Flexible insulating tubing	TH 17316
Antielectrolytic coupling (female)	TH 17400
Antielectrolytic coupling (male)	TH 17385
Self-obturing coupling	TH 17426B

CONSTANT CURRENT CHARACTERISTICS Vg2 = 500 V

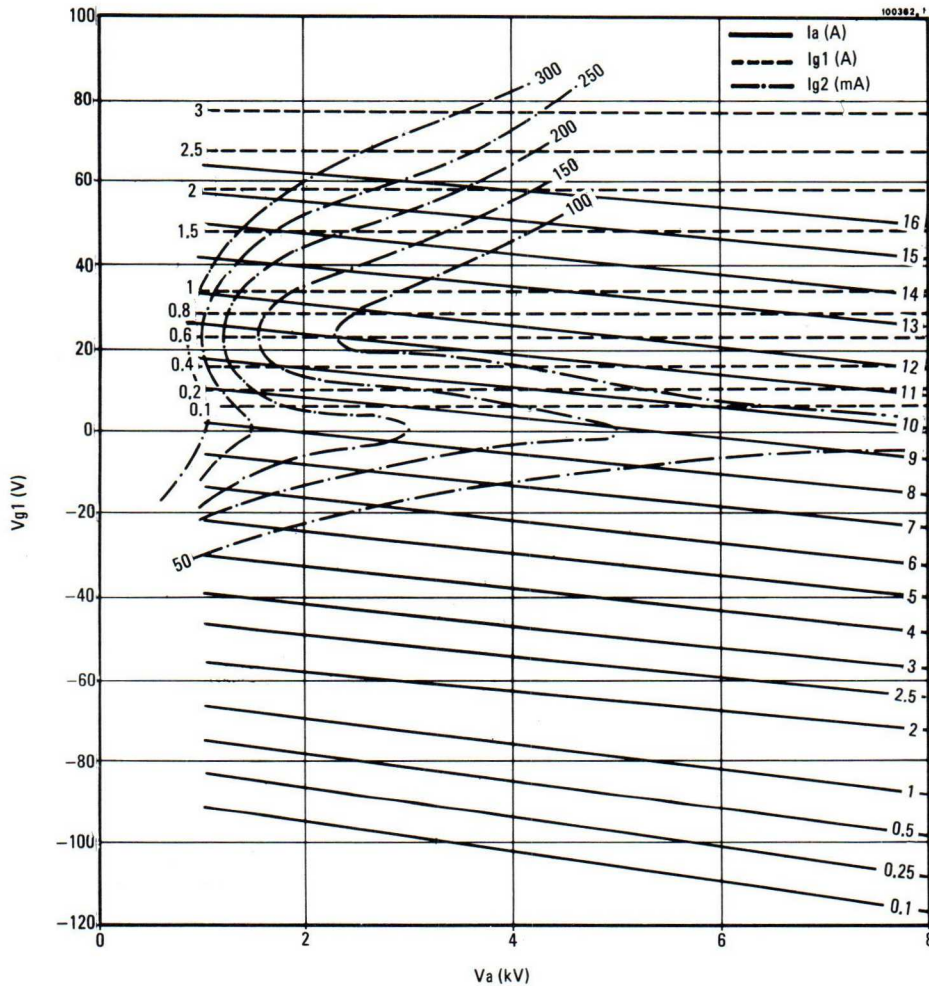

TH 573 HYPERVAPOTRON[®] TETRODE WITH PYROBLOC[®] GRIDS



- **Output power :**
 - 350 kW in LW and MW
 - 300 kW in SW
- **Operating frequency up to 110 MHz**
- **High gain**
- **High operation stability thanks to the Pyrobloc[®] grids**
- **Maximum anode dissipation 300 kW with Hypervapotron[®] cooling**

GENERAL CHARACTERISTICS

Electrical

Type of cathode	Thoriated tungsten
Heating	Direct, dc or single-phase ac
Heater voltage	Note (1)
Heating current, approx. (2)	490 A
Interelectrode capacitances, approx. :	
- cathode control grid	355 pF
- control grid - screen grid	610 pF
- control grid - anode	4.7 pF
- screen grid - anode	85 pF
Amplification factor, average	4.3
Transconductance (I _a = 25 A, V _{g2} = 1000 V)	400 mA/V

(1) Thomson-CSF defines the operating heater voltage according to each particular situation. See paragraph V: "OPERATING INFORMATION AND RECOMMENDATIONS".

(2) The indicated heating current corresponds to a heater voltage of 15 V. Both values are only approximate, allowing to choose the heater power supply.

Mechanical

Operating position	Vertical, anode up
Weight, approx.	60 kg
Dimensions	See the Outline Drawing

Anode Cooling

Type	Hypervapotron
Maximum anode dissipation	300 kW
Minimum corresponding water flow	150 l/min
Maximum water pressure at the input of the cooler	5 bar
Maximum water temperature at the output	100 °C

Electrode Terminal Cooling

Type	Forced air
Cooling with TH 16124 connector :	
- minimum flow	1.6 m ³ /min
- corresponding pressure drop	18 mbar
Maximum temperature on the envelope of the tube (ceramic seals and electrode terminals) ..	200 °C

RF AMPLIFIER OPERATION
(Telephony, maximum frequency 30 MHz)

Absolute Ratings

Aanode voltage	13 kV
Control grid voltage (dc)	— 800 V
Screen grid voltage (dc)	1200 V
Peak cathode current	400 A
Anode dissipation	300 kW
Control grid dissipation	2 kW
Screen grid dissipation	5 kW

Typical Operation (carrier conditions)

Output power (3)	305 kW
Frequency	30 MHz
Anode voltage (dc)	11 kV
Anode direct current	36 A
Control grid voltage (dc)	— 550 V
Control grid direct current	2 A
Screen grid voltage (dc)	1000 V
Screen grid direct current	1.3 A
Anode dissipation	91 kW
Control grid dissipation	300 W
Screen grid dissipation	1.3 kW

(3) Without taking circuit losses into account.

ACCESSORIES

Connector	TH 16124
Flexible insulating tubing	TH 17317
Antielectrolytic coupling	TH 17399
Self-obturator coupling	TH 17415B
Lifting device	TH 14218

CONSTANT CURRENT CHARACTERISTICS

$V_{g2} = 1000 \text{ V}$

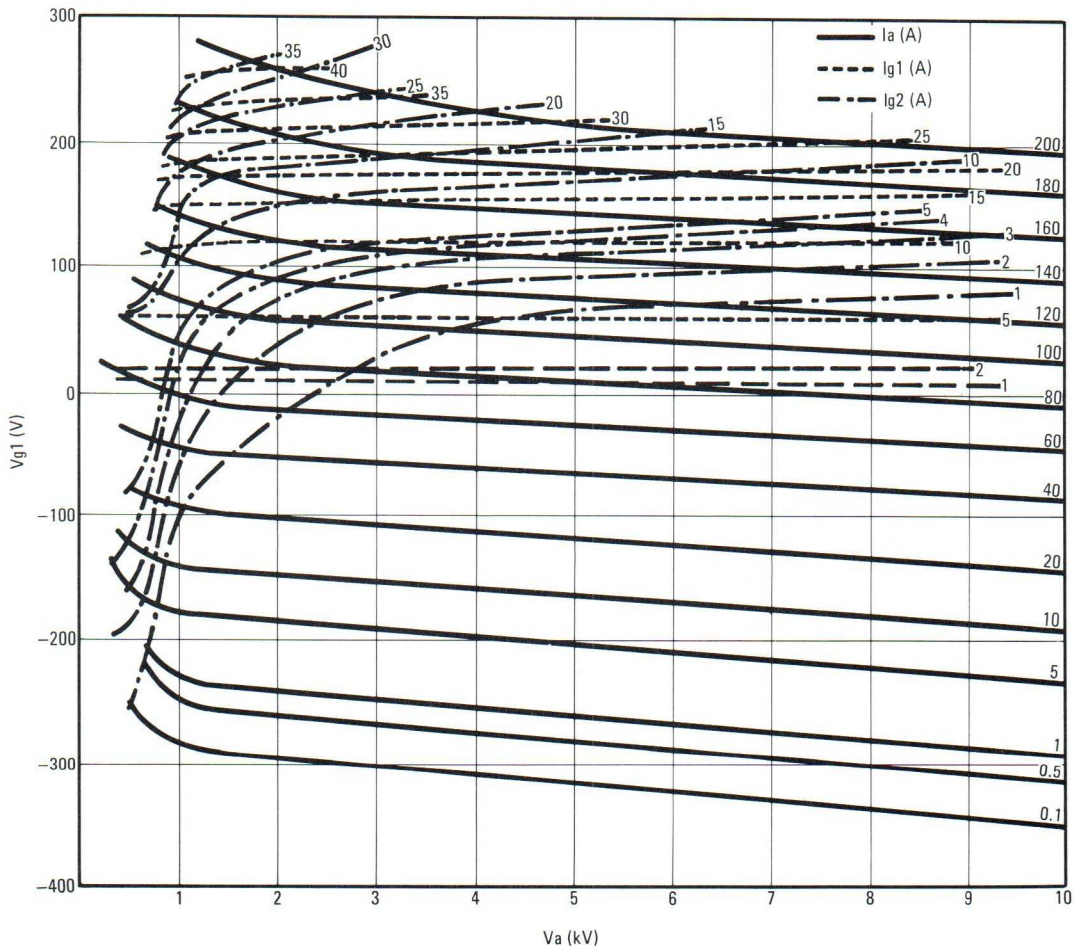

TH 573V SUPERVAPOTRON[®] TETRODE WITH PYROBLOC[®] GRIDS

- Output power : 300 kW in LW and MW
- Operating frequency up to 110 MHz
- High gain
- High operation stability thanks to the Pyrobloc[®] grids
- Maximum anode dissipation 170 kW with Supervapotron[®] cooling



GENERAL CHARACTERISTICS

Electrical

Type of cathode	Thoriated tungsten
Heating	Direct, dc or single-phase ac
Heater voltage	Note (1)
Heating current, approx. (2)	500 A
Interelectrode capacitances :	
- cathode - control grid	355 pF
- control grid - screen grid	610 pF
- control grid - anode	4.7 pF
- screen grid - anode	80 pF
Amplification factor, average	4.3
Transconductance (I _a = 25 A, V _{g2} = 1000 V)	400 mA/V

(1) Thomson-CSF defines the operating heater voltage according to each particular situation. See paragraph V: "OPERATING INFORMATION AND RECOMMENDATIONS".

(2) The indicated heating current corresponds to a heater voltage of 15 V. Both values are only approximate, allowing to choose the heater power supply.

Mechanical

Operating position	Vertical
Weight, approx. (without boiler)	58 kg
Dimensions	See the Outline Drawing

Anode Cooling

Type	Supervapotron
Maximum anode dissipation	170 kW

Electrode Terminal Cooling

Type	Forced air
Cooling with TH 16107A :	
- minimum flow	1.6 m ³ /min
- corresponding pressure drop	18 mbar
Maximum temperature on the tube (ceramic seals and electrode terminals)	200 °C

RF AMPLIFIER OPERATION (Telephony, maximum frequency 30 MHz)

Absolute Ratings

Anode voltage (dc)	13 kV
Control grid voltage (dc)	— 800 V
Screen grid voltage (dc)	1200 V
Peak cathode current	400 A
Anode dissipation	170 kW
Control grid dissipation	2 kW
Screen grid dissipation	5 kW

Typical Operation (carrier conditions)

Output power (3)	305 kW
Frequency	30 MHz
Anode voltage (dc)	11 kV
Anode direct current	36 A
Control grid voltage (dc)	— 550 V
Control grid direct current	2 A
Screen grid voltage (dc)	1000 V
Screen grid direct current	1.3 A
Anode dissipation	91 kW
Control grid dissipation	300 W
Screen grid dissipation	1.3 kW

(3) Without taking circuit losses into account.

ACCESSORIES

RF connector	TH 16107A
Boiler	TH 17034
Toroidal gasket	TH 17819
Vapor outlet pipe	TH 17320
Flexible insulating tubing	TH 17817
Antielectrolytic coupling	TH 17395
Insulating pipe for water inlet	TH 17321
Lifting device (tube)	TH 14215
Lifting device (boiler)	TH 14216

CONSTANT CURRENT CHARACTERISTICS

$V_{g2} = 1000 \text{ V}$

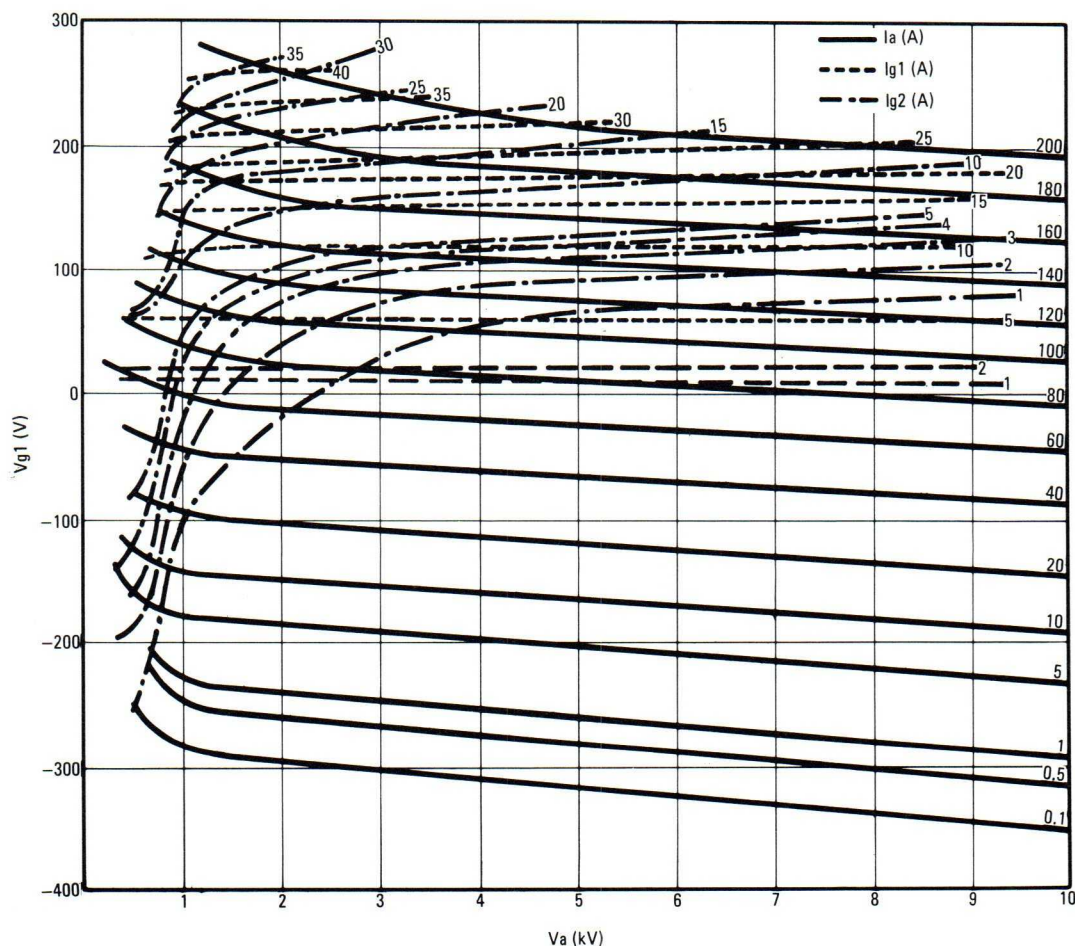

TH 581 HYPERVAPOTRON[®] TETRODE WITH PYROBLOC[®] GRIDS

- Output power : 125 kW in MW and SW
- Operating frequency up to 110 MHz
- High gain
- High operation stability thanks to the Pyrobloc[®] grids
- Maximum anode dissipation 150 kW with Hypervapotron[®] cooling



GENERAL CHARACTERISTICS

Electrical

Type of cathode	Thoriated tungsten
Heating	Direct, dc or single-phase ac
Heater voltage	Note (1)
Heating current, approx. (2)	280 A
Interelectrode capacitances, approx. :	
- cathode - control grid	180 pF
- control grid - screen grid	310 pF
- control grid - anode	2.3 pF
- screen grid - anode	47 pF
Amplification factor, average	5
Transconductance (I _a = 25 A, V _{g2} = 1000 V)	140 mA/V

(1) Thomson-CSF defines the operating heater voltage according to each particular situation. See paragraph V : "OPERATING INFORMATION AND RECOMMENDATIONS".

(2) The indicated heating current corresponds to a heater voltage of 10 V. Both values are only approximate, allowing to choose the heater power supply.

Mechanical

Operating position	Vertical, anode up
Weight, approx.	35 kg
Dimensions	See the Outline Drawing

Anode Cooling

Type	Hypervapotron
Maximum anode dissipation, continuous ..	150 kW
Minimum corresponding water flow	70 l/min
Maximum water pressure at the input	5 bar
Maximum water temperature at the output ..	100 °C

Electrode Terminal Cooling

Type	Forced air
Cooling with TH 16111 connector :	
- minimum flow	1 m ³ /min
- corresponding pressure drop	12 mbar
Maximum temperature on the tube (ceramic seals and electrode terminals)	200 °C

RF AMPLIFIER OPERATION (Telephony, maximum frequency 30 MHz)

Absolute Ratings

Anode voltage (dc)	12 kV
Control grid voltage (dc)	— 800 V
Screen grid voltage (dc)	1200 V
Peak cathode current	160 A
Anode dissipation	150 kW
Control grid dissipation	0.8 kW
Screen grid dissipation	2 kW

(3) Without taking circuit losses into account.

Typical Operation (carrier conditions)

Output power (3)	125 kW
Frequency	30 MHz
Anode voltage (dc)	11 kV
Anode direct current	15 A
Control grid voltage (dc)	— 550 V
Control grid direct current	0.8 A
Screen grid voltage (dc)	1000 V
Screen grid direct current	0.5 A
Anode dissipation	40 kW
Control grid dissipation	120 W
Screen grid dissipation	0.5 kW

ACCESSORIES

Connector	TH 16111
Flexible insulating tubing	TH 17317
Antielectrolytic coupling	TH 17399
Self-obturator coupling	TH 17415B
Lifting device	TH 14218

CONSTANT CURRENT CHARACTERISTICS

$V_{g2} = 1000 \text{ V}$

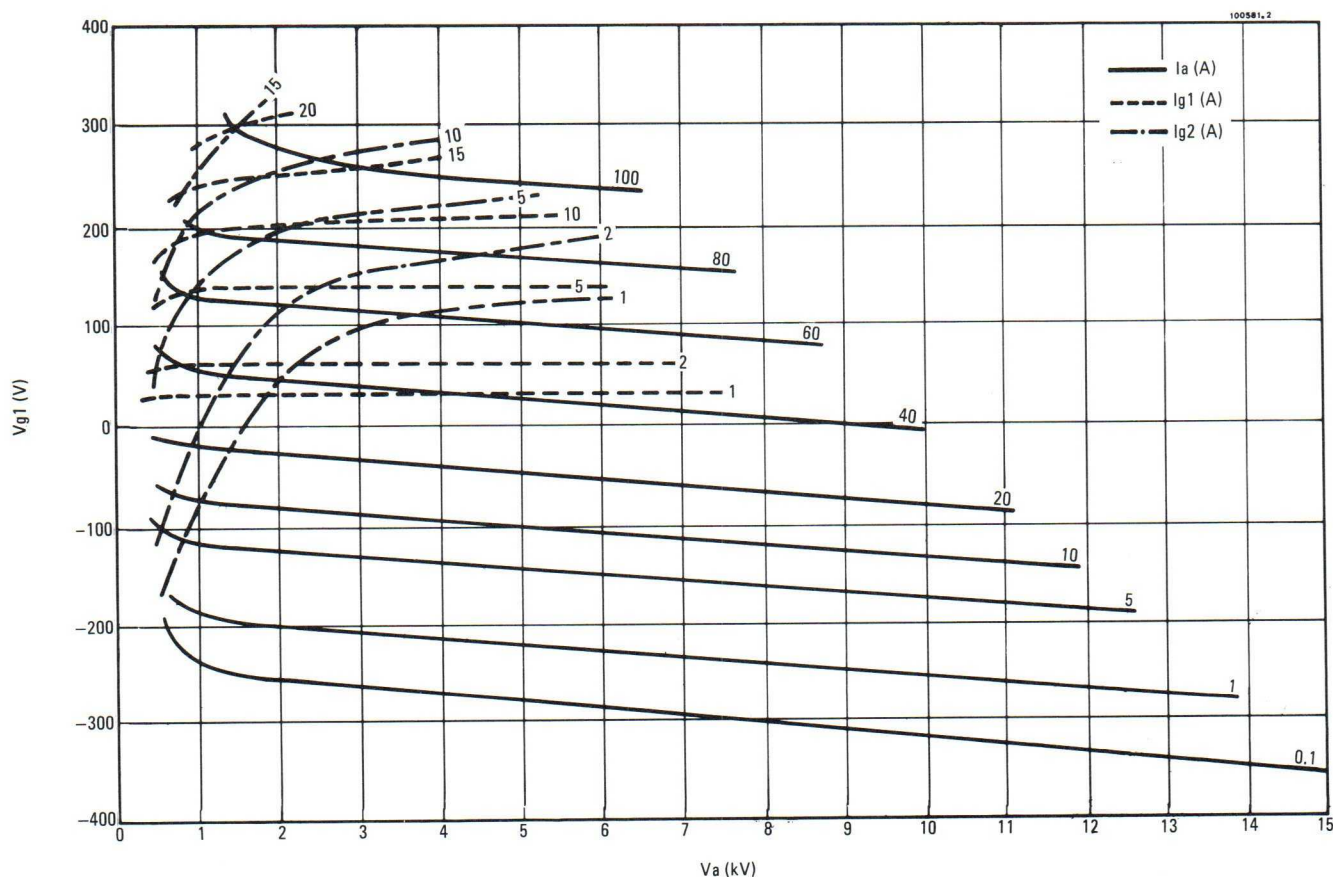

TH 581V SUPERVAPOTRON[®] TETRODE WITH PYROBLOC[®] GRIDS



- Output power : 125 kW in MW and SW
- Operating frequency up to 110 MHz
- High gain
- High operation stability thanks to the Pyrobloc[®] grids
- Maximum anode dissipation 75 kW with Supervapotron[®] cooling

GENERAL CHARACTERISTICS

Electrical

Type of cathode	Thoriated tungsten
Heating	Direct, dc or single-phase ac
Heater voltage	Note (1)
Heating current, approx. (2)	280 A
Interelectrode capacitances :	
- cathode - control grid	180 pF
- control grid - screen grid	310 pF
- control grid - anode	2.3 pF
- screen grid - anode	47 pF
Amplification factor, average	5
Transconductance (I _a = 25 A, V _{g2} = 1000 V)	140 mA/V

(1) Thomson-CSF defines the operating heater voltage according to each particular situation. See paragraph V : "OPERATING INFORMATION AND RECOMMENDATIONS".

(2) The indicated heating current corresponds to a heater voltage of 10 V. Both values are only approximate, allowing to choose the heater power supply.

Mechanical

Operating position	Vertical
Weight, approx. (without boiler)	29 kg
Dimensions	See the Outline Drawing

Anode Cooling

Type	Supervapotron
Maximum anode dissipation	75 kW

Electrode Terminal Cooling

Type	Forced air
Cooling with TH 16111 connector :	
- minimum flow	1 m ³ /min
- corresponding pressure drop	12 mbar
Maximum temperature on the tube (ceramic seals and electrode terminals)	200 °C

RF AMPLIFIER OPERATION
(Telephony, maximum frequency 30 MHz)

Absolute Ratings

Anode voltage (dc)	12 kV
Control grid voltage (dc)	— 800 V
Screen grid voltage (dc)	1200 V
Peak cathode current	160 A
Anode dissipation	75 kW
Screen grid dissipation	2 W

Typical Operation (carrier conditions)

Output power (3)	125 kW
Frequency	30 MHz
Anode voltage (dc)	11 kV
Anode direct current	15 A
Control grid voltage (dc)	— 550 V
Control grid direct current	0.8 mA
Screen grid voltage (dc)	1000 V
Screen grid direct current	0.5 mA
Anode dissipation	40 kW
Control grid dissipation	120 W
Screen grid dissipation	0.5 kW

(3) Without taking circuit losses into account.

ACCESSORIES

RF connector	TH 16111
Boiler	TH 17034
Toroidal gasket	TH 17819
Vapor outlet pipe	TH 17320
Flexible insulating tubing	TH 17817
Antielectrolytic coupling	TH 17395
Insulating pipe for water inlet	TH 17321
Lifting device (tube)	TH 14215
Lifting device (boiler)	TH 14216

CONSTANT CURRENT CHARACTERISTICS

$V_{g2} = 1000 \text{ V}$

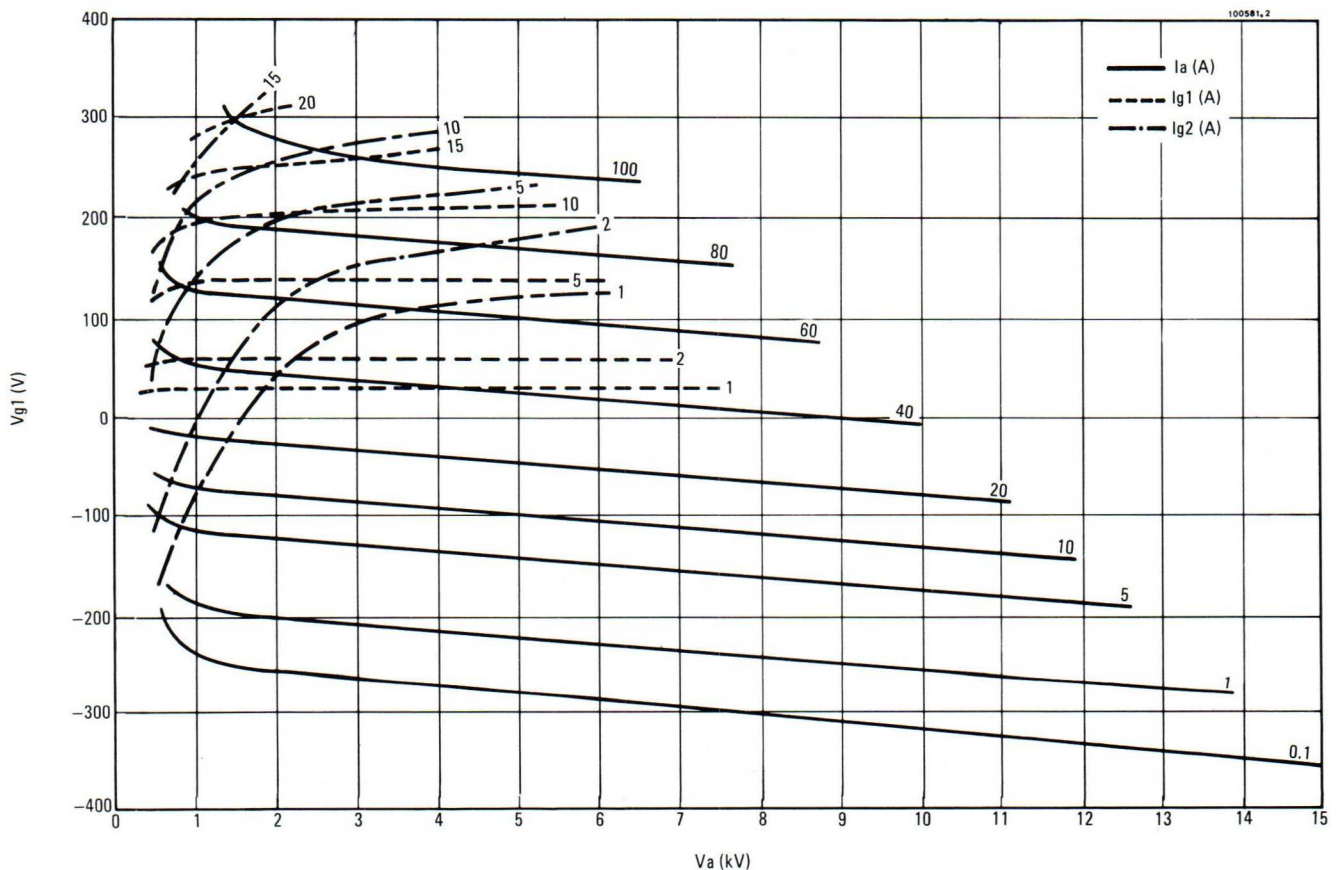

TH 583 HYPERVAPOTRON[®] TETRODE WITH PYROBLOC[®] GRIDS

- Output power : 110 kW
- Operating frequency : audio
- High gain
- High operation stability thanks to the Pyrobloc[®] grids
- Maximum anode dissipation 250 kW with Hypervapotron[®] cooling



GENERAL CHARACTERISTICS

Electrical

Type of cathode	Thoriated tungsten
Heating	Direct, dc or single-phase ac
Heater voltage	Note (1)
Heating current, approx. (2)	320 A
Interelectrode capacitances, approx. :	
- cathode - control grid	245 pF
- control grid - screen grid	400 pF
- control grid - anode	4 pF
- screen grid - anode	62 pF
Amplification factor, average	4.8
Transconductance (I _a = 15 A, V _{g2} = 1000 V)	220 mA/V

(1) Thomson-CSF defines the operating heater voltage according to each particular situation. See paragraph V : "OPERATING INFORMATION AND RECOMMENDATIONS".

(2) The indicated heating current corresponds to a heater voltage of 15 V. Both values are only approximate, allowing to choose the heater power supply.

Mechanical

Operating position	Vertical, anode up
Weight, approx.	38 kg
Dimensions	See the Outline Drawing

Anode Cooling

Type	Hypervapotron
Maximum anode dissipation	250 kW
Minimum corresponding water flow	110 l/min
Maximum water pressure at the input	5 bar
Maximum water temperature at the output	100 °C

Electrode Terminal Cooling

Type	Forced air
Cooling with TH 16110 connector :	
- minimum flow	1 m ³ /min
- corresponding pressure drop	12 mbar
Maximum temperature on the tube (ceramic seals and electrode terminals)	200 °C

AUDIO AMPLIFIER OPERATION

Absolute Ratings

Anode voltage (dc)	15 kV
Control grid voltage (dc)	— 500 V
Screen grid voltage (dc)	1500 V
Peak cathode current	200 A
Anode dissipation	250 kW
Control grid dissipation	1.5 kW
Screen grid dissipation	4 kW

(3) Without taking circuit losses into account.

Typical Operation (values for two tubes)

Output power (3)	2 x 110 kW
Anode voltage (dc)	11 kV
Anode direct current	2 x 14 A
Control grid voltage (dc)	— 330 V
Control grid direct current	0 A
Screen grid voltage (dc)	1100 V
Screen grid direct current	2 x 0.2 A
Anode dissipation	2 x 44 kW
Screen grid dissipation	2 x 220 W

ACCESSORIES

Connector	TH 16110
Flexible insulating tubing	TH 17317
Antielectrolytic coupling	TH 17399
Self-obturator coupling	TH 17415B
Lifting device	TH 14218

CONSTANT CURRENT CHARACTERISTICS

$V_{g2} = 1000 \text{ V}$

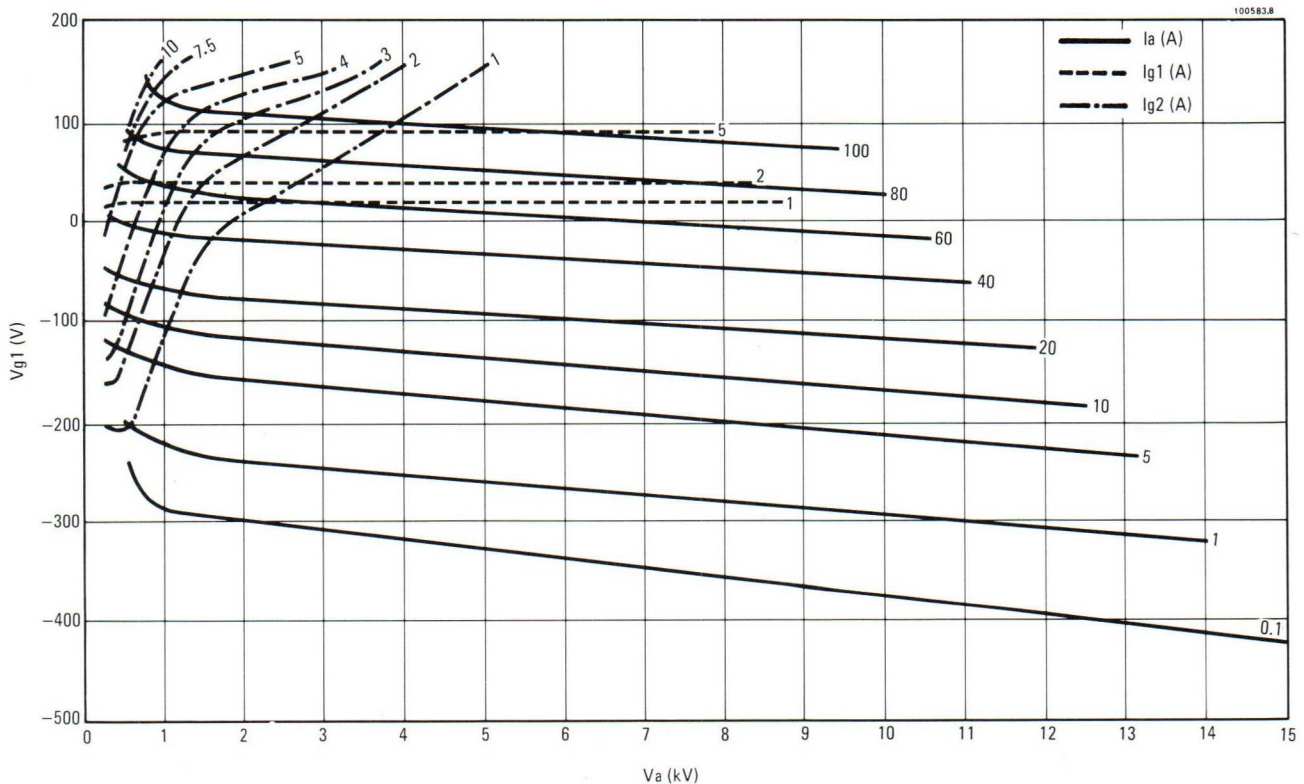

TH 598 HYPERVAPOTRON[®] TETRODE WITH PYROBLOC[®] GRIDS

- Output power : 3 kW
- Operating frequency up to 120 MHz
- High gain
- High operation stability thanks to the Pyrobloc[®] grids
- Maximum anode dissipation 5 kW with Hypervapotron[®] cooling



GENERAL CHARACTERISTICS

Electrical

Type of cathode	Thoriated tungsten
Heating	Direct, dc or single-phase ac
Heater voltage	Note (1)
Heating current, approx. (2)	50 A
Interelectrode capacitances :	
- cathode - control grid	40 pF
- control grid - screen grid	75 pF
- control grid - anode	0.4 pF
- screen grid - anode	11.5 pF
Amplification factor, average	7
Transconductance (I _a = 15 A, V _{g2} = 600 V)	40 mA/V

(1) Thomson-CSF defines the operating heater voltage according to each particular situation. See paragraph V : "OPERATING INFORMATION AND RECOMMENDATIONS".

(2) The indicated heating current corresponds to a heater voltage of 6 V. Both values are only approximate, allowing to choose the heater power supply.

(3) The pressure drop depends on the type of connector.

Mechanical

Operating position	Vertical
Weight, approx.	3 kg
Dimensions	See the Outline Drawing

Anode Cooling

Type	Hypervapotron
Maximum anode dissipation	5 kW
Minimum water flow	2 l/min
Maximum pressure at the input of the cooler	5 bar
Maximum water temperature at the output	100 °C

Electrode Terminal Cooling

Type	Forced air
Cooling with connector :	
- minimum flow	0.5 m ³ /min
- corresponding pressure drop	note (3)
Maximum temperature on the tube (ceramic seals and electrode terminals)	250 °C

RF AMPLIFIER OPERATION
(Telephony, maximum frequency 30 MHz)

Absolute Ratings

Anode voltage (dc)	5 kV
Control grid voltage (dc)	— 200 V
Screen grid voltage (dc)	800 V
Peak cathode current	10 A
Direct anode current	2.5 A
Anode dissipation	5 kW
Screen grid dissipation	100 kW

Typical Operation (carrier conditions)

Output power (4)	3 kW
Frequency	108 MHz
Anode voltage (dc)	5 kV
Anode direct current	0.8 A
Control grid voltage (dc)	— 80 V
Control grid direct current	20 mA
Screen grid voltage (dc)	400 V
Screen grid direct current	35 mA

ACCESSORIES

Flexible insulating tubing	TH 17323
Antielectrolytic coupling	TH 17392
Self-obturator coupling	TH 17410
Intermediate coupling	TH 17412

CONSTANT CURRENT CHARACTERISTICS

$V_{g2} = 600 \text{ V}$

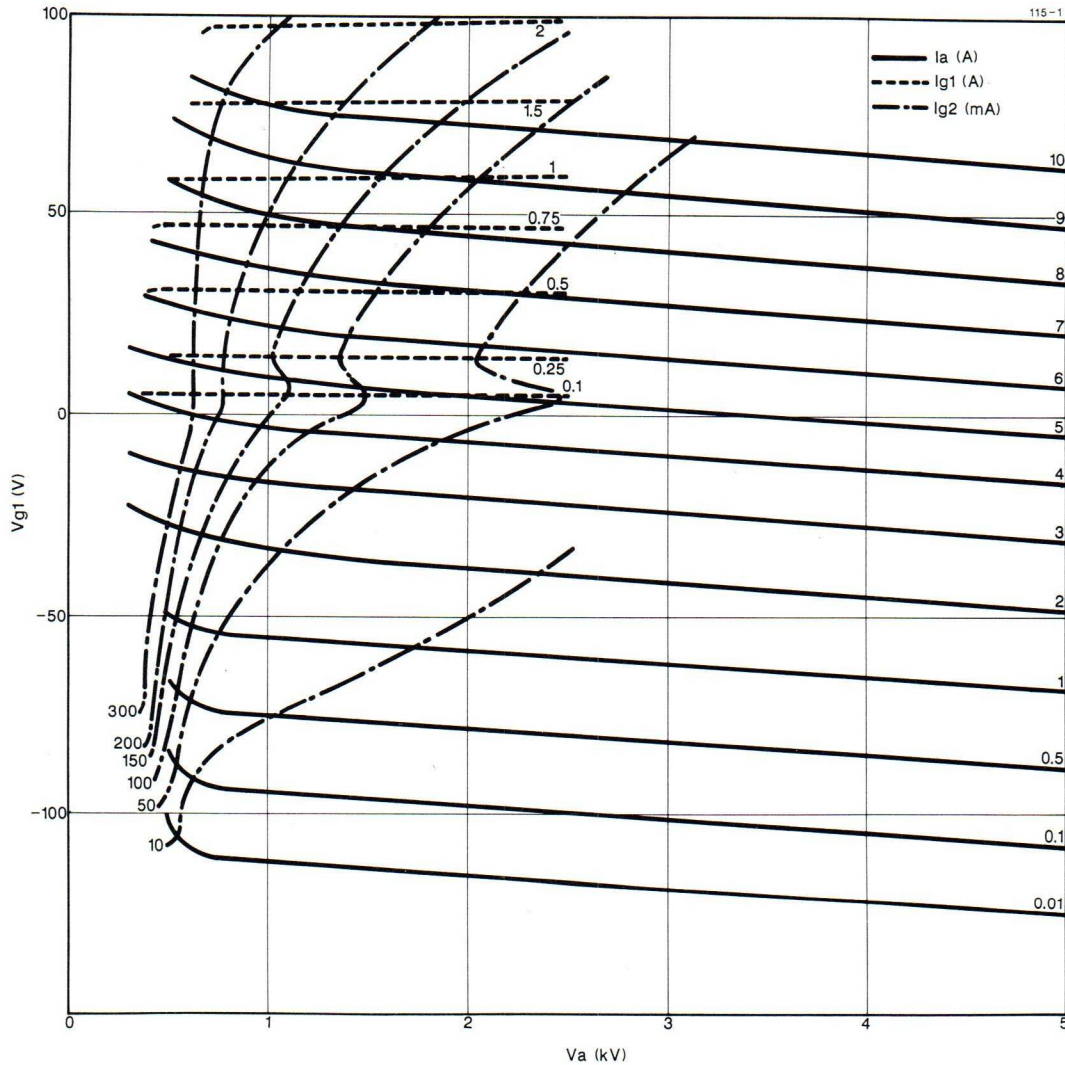

TUBE OUTLINE DRAWINGS

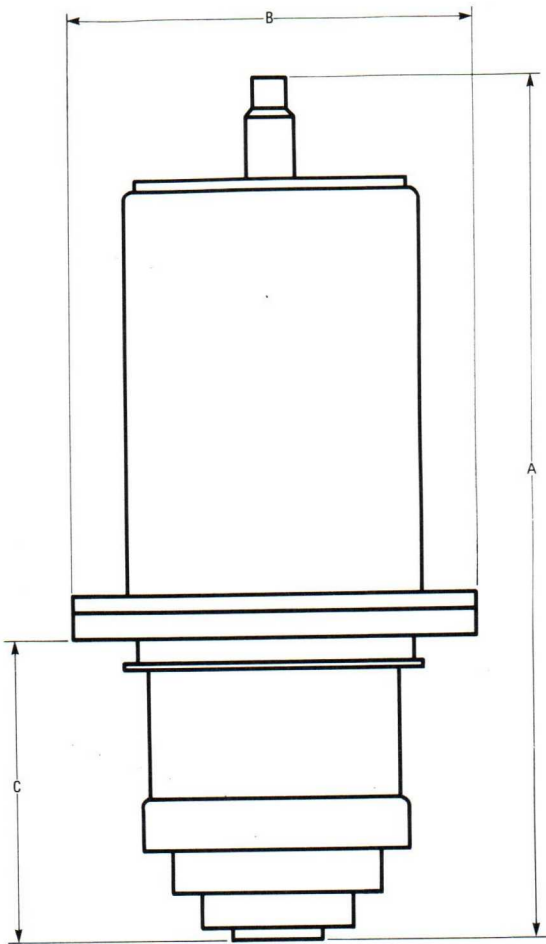

[®]
HYPERVAPOTRON TUBE (H)

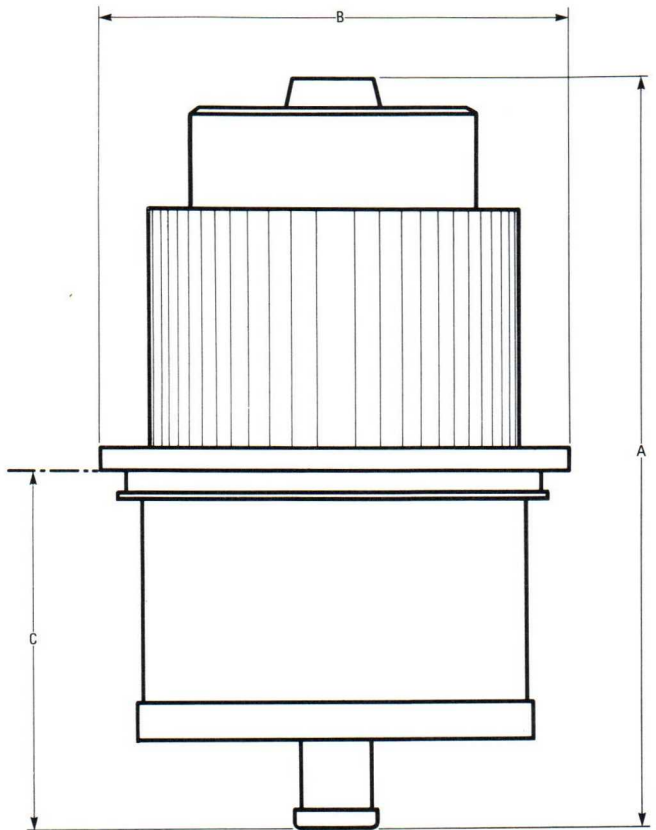

[®]
SUPERVAPOTRON TUBE (S)

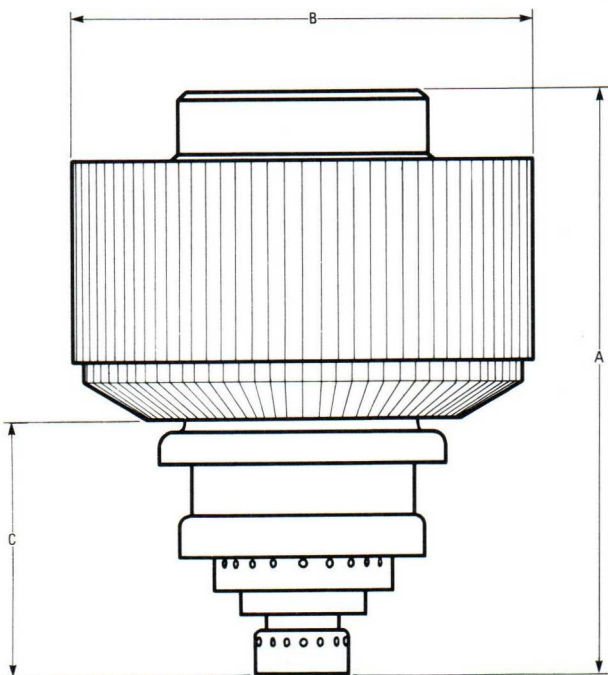

FORCED — AIR TUBE (A)

TUBE DIMENSIONS

TUBE	TYPE	DIMENSIONS*		
		A	B	C
TH 349	A	120	85	47
TH 362	A	170	169	69
TH 376	A	142	103	59
TH 399	A	170	169	69
TH 532	H	390	190	172
TH 537	H	560	310	360
TH 539	H	885	410	272
TH 548	S	610	310	270
TH 555	H	575	270	198
TH 558	H	653	320	258
TH 561	H	195	128	67
TH 562	H	200	128	65
TH 573	H	583	320	258
TH 573V	S	515	310	251
TH 581	H	520	270	198
TH 581V	S	490	270	198
TH 583	H	575	270	198
TH 598	H	156	108	61

* Indicative values; the exact values are given in the respective data sheet.

France

THOMSON-CSF Division Tubes Electroniques
38 rue Vauthier - B.P. 305
F-92102 BOULOGNE-BILLAN COURT CEDEX
Tel. : (33.1) 46 04 81 75 - Telex : THOMTUB 200772 F

Brasil

THOMSON-CSF COMPONENTES DO BRASIL Ltda
Avenida Roque Petroni JR. NR 1464
CEP 04707 - BROOKLIN - SAO PAULO
Tel. : (55.11) 542 4722 - Telex : (011) 24226 TCSF BR

Canada

THOMSON-CSF LTD LTEE
1000 Sherbrooke Ouest - Suite 2340
MONTREAL H3A 3G4 - QUEBEC
Tel. (1-514) 288 41 48
Telex 5560248 TESAFI MTL

Deutschland

THOMSON-CSF BAUELEMENTE GmbH
Bereich Elektronenröhren
Perchtinger Str. 3 - Postfach 701909
8000 MÜNCHEN 70
Tel. (49.89) 7879-0 - Telex : 522916 CSF D

Espana

THOMSON-CSF COMPONENTES Y TUBOS SA
Calle Albacete 5
E-28027 MADRID
Tel. : (34.1) 405 16 15 - Telex : 46033 TCCE E

Italia

THOMSON-CSF COMPONENTI
Via Sergio 1º, 32
I-00165 ROMA
Tel. : (39.6) 639 02 48 - Telex : 620683 THOMTE-I

Japan

THOMSON JAPAN KK
TBR Building 701 - Kojimachi 5-7 - Chiyoda-Ku
TOKYO 102
Tel. (81.3) 264 63 46 - Telex : 2324241 THCSF J

Sverige

THOMSON-CSF ELEKTRONRÖR AB
Radiovägen 1 a
Postadress : Box 631
135 26 TYRESÖ
Tel. (46.8) 742 80 10

United Kingdom

THOMSON-CSF COMPONENTS AND MATERIALS Ltd
Ringway House - Bell Road
GB-BASINGSTOKE RG 24 OQG
Tel. (44.256) 29 155 - Telex : 858865 TESAFI G

USA

THOMSON ELECTRON TUBES AND DEVICES CORP.
550 Mount Pleasant Avenue
P.O. Box 6500
DOVER - NEW JERSEY 07801
Tel. : (1.201) 328-1400
TWX : 710 987 7901 DUMONT DOVR

For all other countries, please contact FRANCE

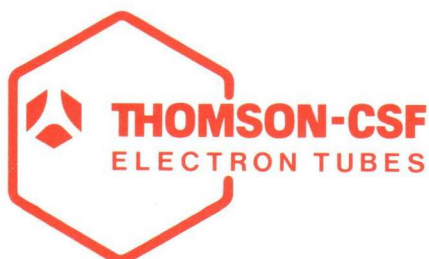



THOMSON-CSF

DIVISION TUBES ELECTRONIQUES

38 rue Vauthier / BP 305 /
F-92102 BOULOGNE-BILLANCOURT CEDEX / FRANCE
Tél. : (1) 46.04.81.75 / Télex : Thomtub 200772 F