

TECHNICAL INFORMATION BULLETIN

# X-BAND tunable magnetron

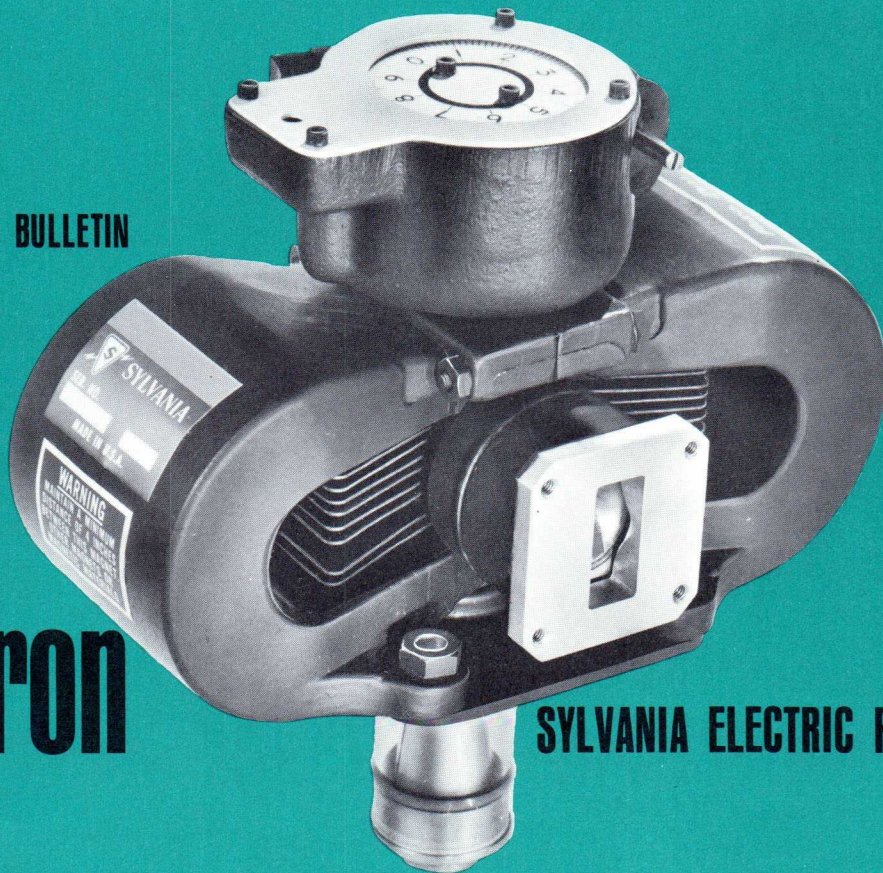

SYLVANIA ELECTRIC PRODUCTS INC.





# X-BAND TUNABLE MAGNETRON

8500 - 9650 Mc	FORCED AIR COOLED
220 Kw PEAK POWER	INTEGRAL MAGNETS
SERVO TUNABLE	PULSED OPERATION
LOW DRIVE TORQUE	RUGGEDIZED
LINEAR TUNING RESPONSE	RELIABLE LIFE

The SYLVANIA X-Band, Tunable Magnetron is a highly stable pulsed magnetron offering 220 KW peak power output over the 8500 to 9650 Mc range. It combines a new tuner design with a proven dispenser type cathode in a rugged package capable of withstanding heavy shock and excessive temperatures. This magnetron is available in various versions each of which is designed for a particular system application. The M-4193A is the SYLVANIA type which is manufactured to and complies with the USAF 7008 specification, dated 22 May 1961, and is intended as a premium replacement in systems using that tube. Other presently available versions of this tunable magnetron are the 7006, M-4164, 7692\* type, and the M-4193C type. Reference throughout this bulletin will normally be to the 7692A\* since it is typical of the exceptional performance available from this advanced line of SYLVANIA tunable magnetrons.

The "Inductive Post Tuner," a Sylvania design, provides linear tuning. This simplifies local oscillator tracking by eliminating associated compensating equipment required with coupled cavity tubes. The features of this tuner are—a single bellows that tunes all posts simultaneously—secure and precise alignment of the tuning posts by means of a guide ring that also serves as an effective heat sink—free tuning post length restricted to 0.200 inches, eliminating electrical and mechanical resonances at normally encountered vibration frequencies—electrically and thermally grounding the tuning posts for very low thermal drift. This tuning design makes this tube particularly suitable for applications requiring rapid servo-tuning while the transmitter is in continual operation.

A reliable dispenser type cathode, incorporated in the SYLVANIA X-Band Tunable Magnetron, features low heater power requirements resulting in low cathode temperatures, high stability and outstanding life. Cathode memory is of extremely short duration such that abrupt switches in pulse length do not detract from cathode performance or life. In addition, the molybdenum cathode support is virtually unyielding to vibration stresses, and exhibits very low heat loss permitting zero heater voltage operation at rated anode currents.

The SYLVANIA X-Band Tunable Magnetron is designed for transmitter service in airborne fire control systems and in navigational systems. This magnetron is useful in ground as well as airborne installation where a high-performance X-Band r.f. oscillator is required.

Additional information and assistance with specific applications may be obtained by contacting:

## SYLVANIA ELECTRIC PRODUCTS INC.

Microwave Device Division  
Applications Department  
1891 East Third Street  
Williamsport, Pennsylvania

*\*7692 and 7692A are Electronic Industries Association registration numbers for two SYLVANIA tunable X-Band magnetrons, formerly known as M-4193B and M-4193D respectively.*

# M-4193A

## MECHANICAL SPECIFICATIONS

Mounting Position . . . . . Any Dimension . . . . . See Dimensional Outline Waveguide Output Flange . . . . . Mates with Modified JAN-UG-52A/U Cathode Connector . . . . . The heater terminal and the heater-cathode terminal require the use of a connector with flexible leads such as the Ucinite No. 115364 with built-in capacitor, or its equivalent. The complete cathode bushing may be either immersed in oil or pressurized. Input and Output Pressurization<sup>1</sup> . . . . . 45 psia max. Weight (Net) . . . . . Approx. 12 lbs. Weight (Shipping) . . . . . Approx. 25 lbs. Magnet Isolation . . . . . 6 inches min. Vibration<sup>2</sup> . . . . . 5 g max., 5-500 cycles Shock . . . . . 30 g for 11 milliseconds Tuning<sup>3</sup> . . . . . Tuning is accomplished through a low torque servo-drive shaft. A combination digital and dial indicator provides a calibrated measure of frequency. The tuning mechanism is designed to give linear frequency response versus dial settings. See Figure 1. Shaft Revolutions to cover full range of 8500 to 9600 (approx.) . . . . . 160 Maximum applied Torque at stop . . . . . 200 in. oz. Tuning Torque (Max.) between -55°C and +150°C . . . . . 16 in. oz. Backlash<sup>4</sup> . . . . . 225° (Max.) Tuning Rate (Max.) . . . . . 1750 rpm 200 Mc/Sec. Tuner Life (Min.) . . . . . 5000 cycles Cooling . . . . . Cooling air, should be directed along the fins toward the body of the tube. Adequate flow should be provided so that the temperature of the anode block does not exceed 150°C. The temperature of the heater-cathode terminal should be maintained below 230°C. For extended tube life it is recommended that these temperatures be maintained below 100°C. Typical air flow requirements with maximum back pressure of 3 inches are shown in Figure 2.

## ELECTRICAL SPECIFICATIONS

### GENERAL DATA

Heater  
Standby Voltage (AC or DC) . . . . . 13.75 V  
Current (at 13.75 V) . . . . . 3.2 A  
Pre-heat Time . . . . . 2.5 Min.  
Tunable Frequency . . . . . 8500 Mc-9600 Mc  
Max. Frequency Pulling at VSWR of 1.5:1 . . . . . 13.5 Mc

### ABSOLUTE MAXIMUM AND MINIMUM RATINGS<sup>5</sup>

Heater Voltages<sup>6</sup> . . . . . 15 V Max.  
Heater Surge Current . . . . . 12 A Max.  
Peak Anode Voltage . . . . . 23 Kv Max.  
Peak Anode Current . . . . . 30 a Max.  
Average Power Input . . . . . 690 W Max.  
Peak Power Input . . . . . 690 kw Max.  
Anode Temperature . . . . . 150°C Max.  
Cathode Bushing, Temperature . . . . . 230°C Max.  
Duty Cycle . . . . . 0.0013 Max.  
Pulse Width . . . . . 3.3 μs Max.  
0.20 μs Min.  
Rate of Rise of Voltage Pulse<sup>7</sup>(tp > 1.0) . . . . . 200 kv/μs Max.  
70 kv/μs Min.  
Rate of Rise of Voltage Pulse (tp < 1.0) . . . . . 225 kv/μs Max.  
70 kv/μs Min.  
Load Voltage Standing Wave Ratio . . . . . 1.5:1 Max.

### LIFE TEST LIMITS<sup>9</sup>

Power Output (See Figure 3) . . . . . 160 Watts  
Stability Osc. (1) (Max.) . . . . . 0.5 Percent  
Osc. (2) . . . . . 1.0 Percent  
RF Bandwidth (Max.) . . . . . 3.0/tp Mc  
Side Lobes (Min.) . . . . . 5 db  
Partial Moding Osc. (1) . . . . . 0.5 Percent  
Running Torque (Max.) . . . . . 12 in. oz.  
Cathode Memory . . . . . A failure shall have occurred if, at 3 times throughout the test, magnetron arcing has caused the modulator power to be turned off.

### Typical pulsed operation with load VSWR ≤ 1.05 except as noted:

	Osc. (1)	Osc. (3)
Heater Voltage . . . . .	0	0
Peak Anode Voltage . . . . .	22	22 kv
Peak Anode Current . . . . .	27.5	27.5 a
Pulse Repetition Rate . . . . .	4000	400 cps
Pulse Width . . . . .	0.25	2.5 μs
RF Bandwidth with worse phasing of		
1.5 VSWR . . . . .	5.0	0.5 Mc
Side Lobes with worse phasing of		
1.5 VSWR . . . . .	12	8 db
Pulling Figure at VSWR of 1.5 . . . . .	12	12 Mc
Pushing Figure . . . . .	0.2	0.2 Mc/a
Thermal Factor for any 30° Range of Anode-block Temperature Between -55°C and 150°C . . . . .	0.2	0.2 Mc/°C
Backlash <sup>8</sup> . . . . .	2	2 Mc
Starting Torque . . . . .	9	9 in. oz.
Running Torque . . . . .	5	5 in. oz.
Peak Power Output . . . . .	240	240 kw
Stability with worse phasing of 1.5:1 VSWR . . . . .	0.03	0.1 %
Tuning Stability . . . . .	0.2	0.2 %

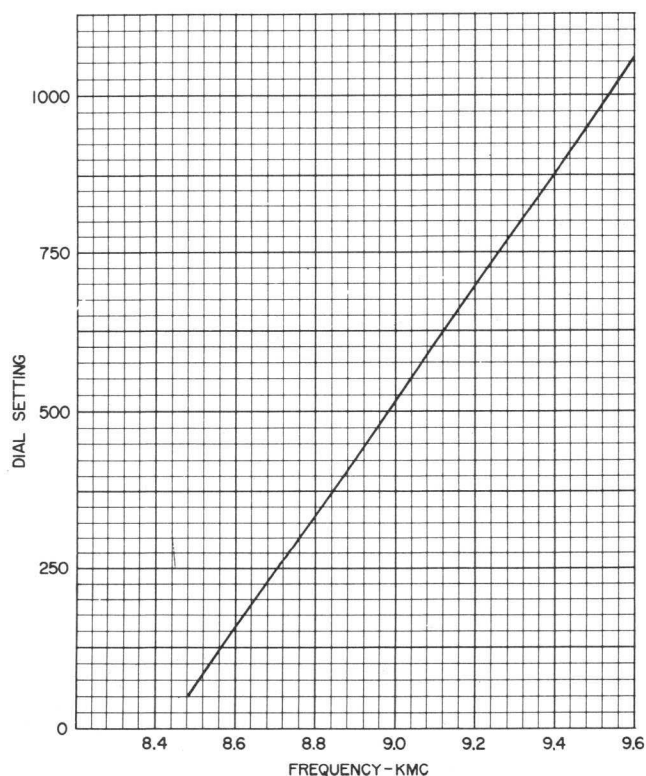

Figure 1—Typical Tuning Response Curve for Sylvania X-Band Magnetron.

# 7006

## MECHANICAL SPECIFICATIONS

Mounting Position.....	Any
Dimension.....	See Dimensional Outline
Waveguide Output Flange.....	Mates with Modified JAN-UG-52A/U
Cathode Connector.....	The heater terminal and the heater-cathode terminal require the use of a connector with flexible leads such as the Ucinite No. 115364 with built-in capacitor, or its equivalent. The complete cathode bushing may be either immersed in oil or pressurized.
Input and Output Pressurization <sup>1</sup> .....	45 psia max.
Weight (Net).....	Approx. 11 lbs.
Weight (Shipping).....	Approx. 25 lbs.
Magnet Isolation.....	4 inches min.
Vibration <sup>2</sup> .....	5 g max., 5-500 cycles
Shock.....	30 g for 11 milliseconds
Tuning <sup>3</sup> .....	Tuning is accomplished through a worm and gear drive shaft for manual adjustment. This tuner is also adaptable to servo-motor operation on special request. A combination digital and dial indicator provides a calibrated measure of frequency. The tuning mechanism is designed to give linear frequency response versus dial settings. See Figure 1.
Shaft Revolutions to cover full range of 9000 to 9600 (approx.).....	55
Maximum applied Torque at stop.....	200 in. oz.
Tuning Torque (Approx.) at 30°C.....	20 in. oz.
Backlash <sup>4</sup> (Max.).....	10 Mc
Tuner Life (Min.).....	5000 cycles
Cooling.....	Cooling air should be directed along the fins toward the body of the tube. Adequate flow should be provided so that the temperature of the anode block does not exceed 150°C. The temperature of the heater-cathode terminal should be maintained below 165°C. For extended tube life it is recommended that these temperatures be maintained below 100°C. Typical air flow requirements will be similar to Figure 2 and will be dependent on the particular installation.

should be directed along the fins toward the body of the tube. Adequate flow should be provided so that the temperature of the anode block does not exceed 150°C. The temperature of the heater-cathode terminal should be maintained below 165°C. For extended tube life it is recommended that these temperatures be maintained below 100°C. Typical air flow requirements will be similar to Figure 2 and will be dependent on the particular installation.

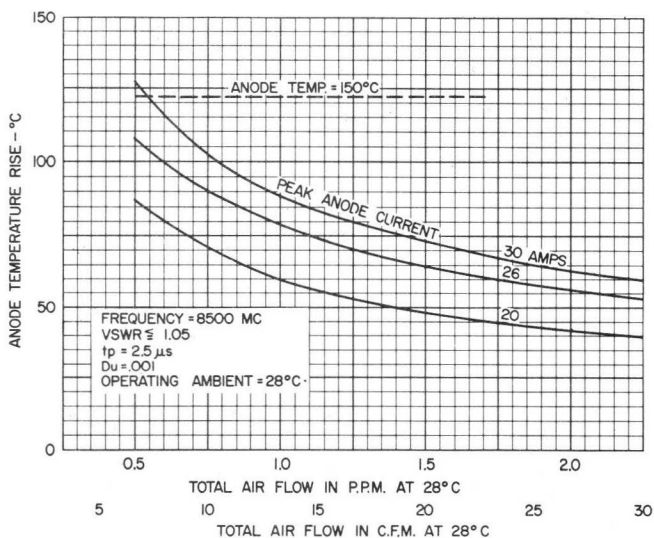

Figure 2—Cooling Requirements for M-4193A.

## ELECTRICAL SPECIFICATIONS

### GENERAL DATA

Heater	
Standby Voltage (AC or DC).....	13.75 V
Current (at 13.75 V).....	3.2 A
Pre-heat Time.....	2.0 Min.
Tunable Frequency.....	9000 Mc-9600 Mc
Max. Frequency Pulling at VSWR of 1.5:1.....	15 Mc
<b>ABSOLUTE MAXIMUM AND MINIMUM RATINGS<sup>5</sup></b>	
Heater Voltages <sup>6</sup> .....	15 V Max.
Heater Surge Current.....	12 A Max.
Peak Anode Voltage.....	23 kv Max.
Peak Anode Current.....	30 a Max.
Average Power Input.....	690 W Max.
Peak Power Input.....	690 kw Max.
Anode Temperature.....	150°C Max.
Cathode Bushing, Temperature.....	165°C Max.
Duty Cycle.....	0.0013 Max.
Pulse Width.....	3.3 μs Max.
	0.20 μs Min.
Rate of Rise of Voltage Pulse <sup>7</sup> (tp < 1.0).....	180 kv/μs Min.
Load Voltage Standing Wave Ratio.....	1.5:1 Max.

### LIFE TEST LIMITS<sup>9</sup>

Power Output (See Figure 3).....	150 Watts
Stability (Max.).....	0.5 Percent
RF Bandwidth (Max.).....	3.0/tp Mc

### Typical pulsed operation with load VSWR ≤ 1.05 except as noted:

	Osc. (1)	Osc. (2)
Heater Voltage.....	0	0
Peak Anode Voltage.....	21	21 kv
Peak Anode Current.....	27.5	27.5 a
Duty Cycle.....	.001	.001 cps
Pulse Width.....	0.25	.45 μs
RF Bandwidth with worse phasing of		
1.5 VSWR.....	4.5	2.5 Mc
Side Lobes with worse phasing of		
1.5 VSWR.....	9.0	— db
Pulling Figure at VSWR of 1.5.....	11	11 Mc
Pushing Figure.....	0.5	0.5 Mc/a
Thermal Factor for any 30° Range of Anode-block Temperature between -55°C and 150°C.....	0.2	0.2 Mc/°C
Backlash <sup>8</sup> .....	8	8 Mc
Peak Power Output.....	210	210 kw
Stability with worse phasing of 1.5:1 VSWR.....	0.5	0.5 %

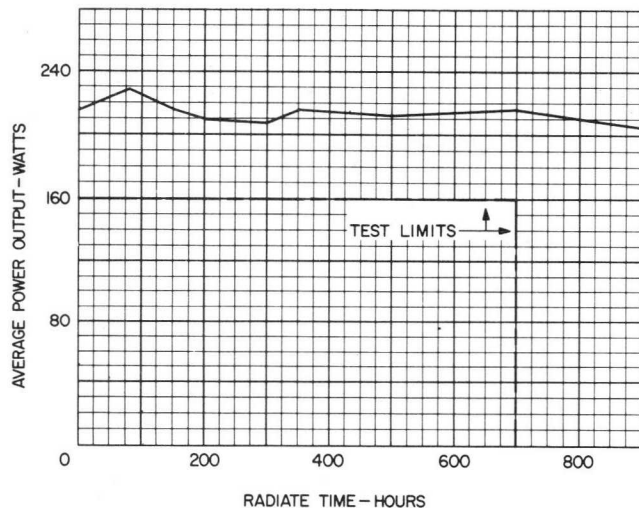

Figure 3—Extended Life Test Output Power.

# 7692A

## MECHANICAL SPECIFICATIONS

Mounting Position	Any
Dimension	See Dimensional Outline
Waveguide Output Flange	Mates with Modified JAN-UG-52A/U
Cathode Connector	The heater terminal and the heater-cathode terminal require the use of a connector with flexible leads such as the Ucinite No. 115364 with built-in capacitor, or its equivalent. The complete cathode bushing may be either immersed in oil or pressurized.
Input and Output Pressurization <sup>1</sup>	45 psia max.
Weight (Net)	Approx. 11 lbs.
Weight (Shipping)	Approx. 25 lbs.
Magnet Isolation	6 inches min.
Vibration <sup>2</sup>	5 g max., 5-500 cycles
Shock	30 g for 11 milliseconds
Tuning <sup>3</sup>	Tuning is accomplished through a low torque servo-drive shaft. A combination digital and dial indicator provides a calibrated measure of frequency. The tuning mechanism is designed to give linear frequency response versus dial settings. See Figure 1.
Shaft Revolutions to cover full range of 8550 to 9650 (approx.)	160
Maximum applied Torque at stop	200 in. oz.
Tuning Torque (Max.) between -55°C and +150°C	16 in. oz.
Backlash <sup>4</sup>	225° (Max.)
Tuning Rate (Max.)	1400 rpm 200 Mc/Sec.
Tuner Life (Min.)	10,000 cycles
Cooling	Cooling air should be directed along the fins toward the body of the tube. Adequate flow should be provided so that the temperature of the anode block does not exceed 150°C. The temperature of the heater-cathode terminal should be maintained below 230°C. For extended tube life it is recommended that these temperatures be maintained below 100°C. Typical air flow requirements will be similar to Figure 2 and will be dependent on the particular installation.

## ELECTRICAL SPECIFICATIONS

### GENERAL DATA

Heater	
Standby Voltage (AC or DC)	13.75 V
Current (at 13.75 V)	3.2 A
Pre-heat Time	2.5 Min.
Tunable Frequency	8550 Mc-9650 Mc
Max. Frequency Pulling at VSWR of 1.2:1	10 Mc

### ABSOLUTE MAXIMUM AND MINIMUM RATINGS<sup>5</sup>

Heater Voltages <sup>6</sup>	15 V Max.
Heater Surge Current	12 A Max.
Peak Anode Voltage	23 kv Max.
Peak Anode Current	30 a Max.
Average Power Input	690 W Max.
Peak Power Input	690 kw Max.
Anode Temperature	150 °C Max.
Cathode Bushing, Temperature	230 °C Max.
Duty Cycle	0.0013 Max.
Pulse Width	3.3 μs Max.
Rate of Rise of Voltage Pulse <sup>7</sup> (tp>1.0)	200 kv/μs Max. 70 kv/μs Min.
Rate of Rise of Voltage Pulse (tp<1.0)	225 kv/μs Max. 70 kv/μs Min.
Load Voltage Standing Wave Ratio	1.5:1 Max.

### LIFE TEST LIMITS<sup>9</sup>

Power Output (See Figure 3)	160 Watts
Stability Osc. (2) (Max.)	0.3 Percent
RF Bandwidth Osc. (2) (Max.)	2.5/tp Mc
Cathode Memory	0.5 Percent

### Typical pulsed operation with load VSWR ≤ 1.05 except as noted:

	Osc. (1)	(2)	(3)
Heater Voltage	8	3	3 V
Peak Anode Voltage	22	22	22 kv
Peak Anode Current	26.0	26.0	26.0 a
Duty Cycle	.0004	.0008	.00075 cs
Pulse Width	0.25	1.0	2.5 μs
RF Bandwidth with worse phasing of 1.5 VSWR	2.0	1.0	1.0 Mc
Side Lobes with worse phasing of 1.5 VSWR	12	8	— db
Pulling Figure at VSWR of 1.2	8	8	10 Mc
Pushing Figure	—	0.2	— Mc/a
Thermal Factor for any 30° Range of Anode-block Temperature between -55°C and 150°C	0.2	—	— Mc/°C
Backlash <sup>8</sup>	5	5	5 Mc
Starting Torque	9	9	9 in. oz.
Running Torque	5	5	5 in. oz.
Peak Power Output	240	240	240 kw
Stability with worse phasing of 1.5:1 VSWR	0.03	0.1	.1 %
Tuning Stability	0.2	0.2	0.2 %
Cathode Memory	0.05	—	— %
Frequency Stability			
Interpulse		500	— Kc
Interpulse		200	— Kc

## NOTES

- With appropriate gasketing, the cathode bushing, or the waveguide output assembly, or both, shall be pressurized such that the input pressure is maintained above 12 psia and the output pressure is maintained between 15 and 45 psia.
- The magnetrons have been operationally tested under the listed conditions with a resulting frequency modulation of less than 0.5 MC.
- Connection to the drive shaft should be through a flexible coupler to reduce axial stress to the tuner mechanism.
- A reversal of the tuning shaft within the specified limit will result in a reversal of frequency of at least 0.5 MC.
- If the independent absolute ratings are exceeded, serviceability of the tube may be impaired. To relate the various dependent ratings, the following formula shall be used:  $P_i = i_b \times D_u \times 21500$ .
- The heater voltage shall be 0 volts for input powers higher than 600 watts. A schedule of permissible heater voltages for reduced power is shown in the application notes.
- The rate of rise of voltage (rrv) is defined by the steepest tangent to the leading edge of the voltage pulse above 50% amplitude.

- Any capacitance used in the viewing probe must not exceed 6.0 μmf.
- The frequency obtained by turning the shaft to a given angular position in one direction will be reproducible within the specified values when returning to that same position from the opposite direction after thermal equilibrium.
- Examination of the tube for compliance with the specified life test limits consists of cycling the tube through various on and off conditions until 700 hours of radiate time is accumulated. The cycle used for life testing the 7692A is as follows: Cathode warm-up for 2.5 minutes. Oscillate at 0.25 μs and .001 duty cycle for 12.5 minutes. Oscillate at 2.5 μs and .001 duty cycle for 12.5 minutes. Off for 7.5 minutes. During this cycle, a VSWR of 1.5:1 is constantly varied through all its phases, and the frequency is changed 100 MC every eight hours. Test conditions for the other X-Band tunable magnetrons have been selected to suit the particular tube application. Information on these test conditions can be obtained from the factory.



# APPLICATION NOTES

## RATINGS

The **Maximum Ratings** listed in the tabulated data are limiting values which must not be exceeded during operation if satisfactory performance is to be obtained. The design of equipment should be based on a value for each rating which insures that the absolute value of the tube rating is never exceeded for normal conditions of supply-voltage variations, load variations, or manufacturing variations in the equipment itself.

To obtain the desired reliability from a system, it is not only necessary that a tube with the required inherent capability be chosen, but the system must be so designed and operated such that this capability is realized. It is essential, therefore, that early in the design phase of the system there be a thorough appreciation for the ratings, limitation and precautions specified for the magnetron.

The **Absolute Ratings** for certain of the operating parameters are dependent ratings and cannot be applied simultaneously. These dependent ratings—average power input, peak anode current, and duty cycle—are related through a formula which is shown in Note 5 with the electrical ratings. Each particular application of the magnetron should be studied for best operation under the conditions above. The equipment designer is encouraged to consult the magnetron manufacturer whenever new or unusual applications are encountered.

## MAGNETIC FIELD

SYLVANIA high power X-band tunable magnetrons are provided with an integral permanent magnet which must be protected to prevent a weakening or distortion of its field. Stored tubes should be separated at least 6 inches to prevent their mutual interaction. In addition, it is recommended that 4 inches separation be maintained between the magnetron and any ferrous material. Under no circumstances should ferrous tools be used on or near the magnetron as they might subject the magnet to sharp shocks which would effect the magnetization.

## "BREAK-IN" PROCEDURE FOR NEW MAGNETRONS

It has been established that the initial instability of a magnetron is proportional to the area of internal metallic surface as well as high voltage potential. Small-size magnetrons, operating at potentials less than a few thousand volts, rarely exhibit heavy instability after storage.

When new magnetrons, or ones which have been in storage for sometime, are operated initially, instability and general roughness of operation may occur. These tubes may be operated at rated magnetron current immediately if continuous arcing does not occur. Continuous arcing should be defined as an uninterrupted chain of arcs exceeding a two second duration. If continuous arcing does occur, the average current level should be reduced immediately to prevent damage to the cathode.

Usually, this slight amount of instability will clean up as the magnetron average current is increased to the operating point. This instability may be caused by small amounts of gas emanating from the metallic surfaces of the vacuum cavity during storage. Clean up or gettering is accomplished by the application of high voltage which ionizes the small amounts of gases driving back into the metallic surfaces and combining them with gettering materials. The most effective method of breaking in a magnetron is to operate it under normal pulse conditions in the radar transmitter. The period required for break-in may extend 15 minutes depending on the operator's skill in performing the steps of the break-in procedure. Extremely severe cases normally requires more time, but this would only be true in a small percentage of the cases.

Proper break-in procedure on magnetrons is difficult with extremely sensitive overload circuitry, which would remove high voltage from the magnetron much too rapidly. These sensitive protective elements tend to reduce the high voltage applied to the modulator or shut it off completely when instability occurs. The action usually takes place within a few tenths of a second after continuous arcing begins. If overload circuitry is utilized, it should be designed to allow continuous magnetron arcing for a period of two to five seconds for proper break-in.

Assume that an attempt is being made to operate the tube by applying high voltage (after the specified pre-heat time) at some average current between zero and the desired operating level and the magnetron is beginning to arc continuously as previously defined. The following steps are recommended for break-in.

1. Maintain the magnetron average current level at a point slightly less than that which produces sustained arcing. It will generally be found that sporadic arcing will occur at this level but within a short period of time the rate of arcing will gradually decrease.
2. Repeat the above procedure at progressively higher levels of average current until the desired operating point is reached. The time required to reach this level is, of course determined by the period required for the arcing to decrease appreciably at each step.
3. In cases where the magnetron does not then operate satisfactorily at the desired average current, it is usually permissible to condition the tube at a value of 10 to 15% higher average anode current until stable operation is obtained at the normal operating point.

Once the procedure mentioned above is complete, trouble-free operation is routine.

The complete disabling or desensitizing of overload devices is not recommended as a standard part of the break-in procedure since damage to the reverse current diode and other modulator components may result.

This procedure should be repeated every three to six months during storage of a magnetron.

## TEMPERATURE CONSIDERATIONS

**Cooling requirement**—Failure to supply cooling air to the anode block and to the cathode terminal will result in tube destruction. An adequate flow of cooling air should be directed so as to maintain the temperature of the anode block below 150°C. Under certain conditions cooling must be applied to the cathode bushing to maintain its temperature below 230°C. The anode and cathode temperatures should be measured by making positive contact with a thermocouple at the locations indicated on the dimensional outline.

Typical air flow requirements are shown in Figure 2 for various levels of average anode current. It should be noted that these curves indicate performance with the tube exposed to a relatively low ambient temperature. If the physical arrangement of the system is so confining such that the ambient temperature around the tube is dependent upon the rate of air flow and the input power to the tube, then an entirely different cooling condition may result. Typical cooling requirements for such a condition are shown in Figure 4.

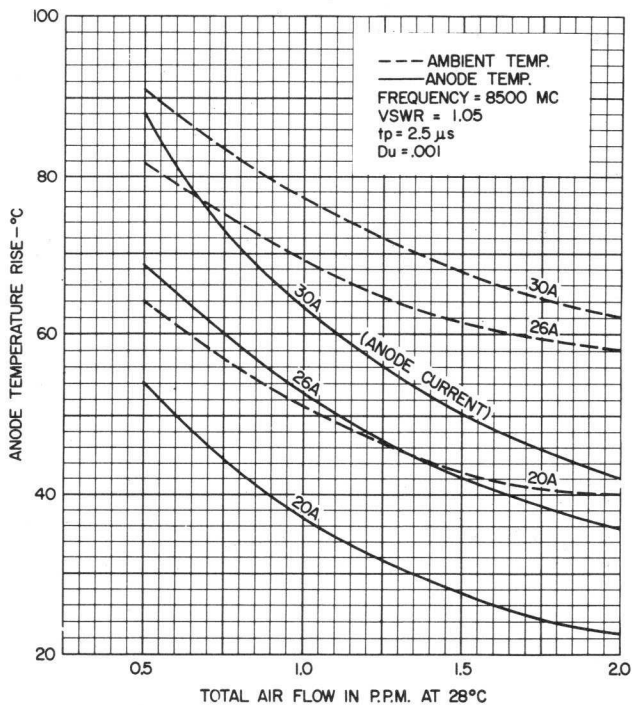

Figure 4—Cooling Requirements for M-4193A in Typical Enclosed Environment.

The data for Figures 2 and 4 were taken using the orifice shown in the dimensional outline of the M-4193A. This orifice was designed to provide adequate cooling for a flow rate of 2 pounds of air per minute delivered into a maximum back pressure of 3 inches of water. This restricting orifice and ducting system can be modified in order to be compatible with a particular cooling system.

**Thermal Factor**—SYLVANIA high power X-band tunable magnetrons are capable of giving satisfactory performance over a wide range of input power levels. A change in the average power will cause a change in the operating temperature of the magnetron elements, thereby causing a frequency shift. Variations in ambient and/or cooling air temperatures will also effect the frequency of oscillation. The magnitude of this shift is a function of the thermal factor (frequency-temperature coefficient) of the individual tube. A typical thermal factor characteristic is shown in Figure 5. Higher operating frequencies generally result in slightly higher thermal factors with a typical value being about 0.2 MC/°C. If the system requires better frequency stability, this frequency shift can be compensated by automatic frequency-control (AFC) applied to the mechanical tuning shaft.

The range of AFC required is a function of the amount of cooling air provided. Typical curves of frequency vs. rate of airflow at two values of duty cycle are shown in Figure 6.

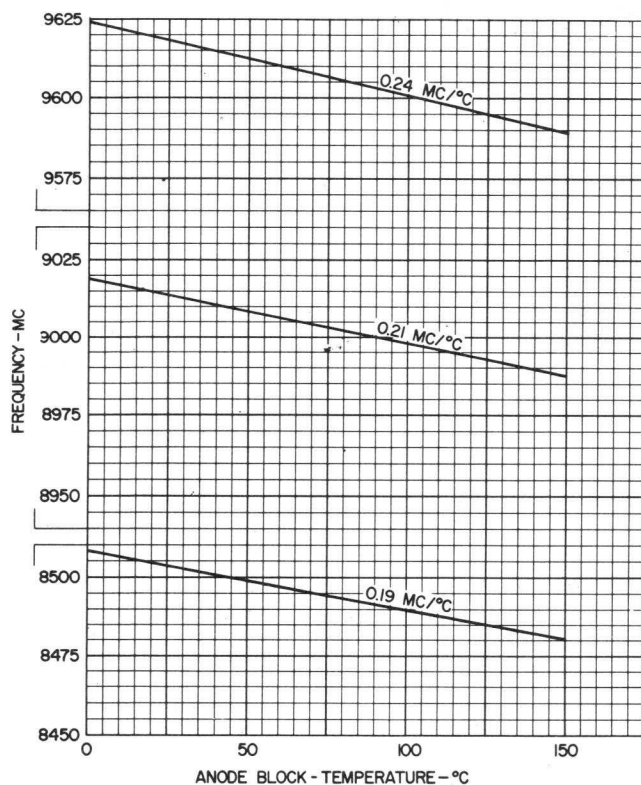

Figure 5—Typical Thermal Factor Characteristic of Sylvania X-Band Tunable Magnetron.

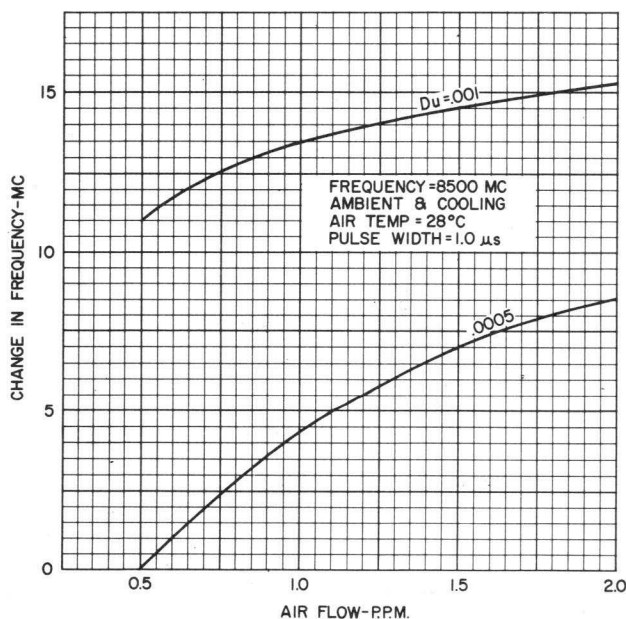

Figure 6—Effect of Cooling Air Flow on Frequency of Typical X-Band Magnetron for Two Different Duty Cycles.



**Thermal Stabilization**—When pulsed high voltage is applied several minutes are required before the anode block reaches a stable temperature. There is a frequency drift occurring during this initial stabilization time which is dependent upon the particular cooling system used. A stabilization curve for a specific installation of the X-band tunable magnetron is shown in Figure 7.

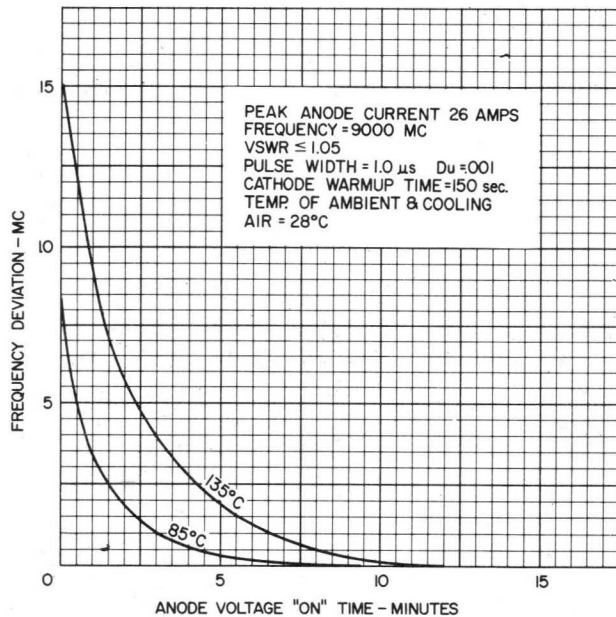

Figure 7—Typical Frequency Stabilization Characteristic.

### HEATER CONSIDERATIONS

When heater voltage is applied to a cold tube, the peak heater surge current must be limited to a maximum value of 12.0 amperes in order to prevent burn-out of the heater. It is desirable that an adjustable heater supply voltage be used to raise the voltage gradually to its rated value. This control may be obtained from a system of time delay relays cutting resistance out of the circuit, a high reactance heater transformer, or a single rheostat. After the heater voltage has been raised to its rated value of 13.75 volts, the cathode must be allowed to warm-up for at least 2½ minutes\* before the high voltage is applied. A modified heater schedule that fulfills the intent of the tube requirement is as follows: Apply 6.85 V ± 5% for 3 minutes followed by application of 13.75 V ± 5% for 90 seconds.

When the magnetron is oscillating, the cathode is subjected to considerable electron bombardment, which raises the temperature of the cathode. The magnitude of this "back-heating" is a function of the power input to the tube and must be compensated by a reduction of the heater voltage. As soon as the tube begins to oscillate, the heater voltage must be reduced in accordance with the following formula:

$$E_f = 13.75 \left( 1 - \frac{P_i}{P_m} \right) \text{ Volts.}$$

Where  $P_i$  is the average input power and  $P_m$  is a parameter between 450 and 600 according to system requirements. This formula is shown graphically in Figure 8. For a particular heater schedule in a new system, it is recommended that the designer consult the applications engineering department of the tube manufacturer.

### INSTALLATION CONSIDERATIONS

It is essential that the negative side of the high voltage supply is connected to the heater cathode terminal rather than to the heater terminal. If the high peak anode currents flow through the heater they can cause heater burn-out.

The leads between the high voltage pulse generator and the magnetron should be kept as short as possible in order to avoid any reactance effects on the pulse waveform. Connections to the cathode should be firm but not rigid. The cathode bushing operates through a wide range of temperatures requiring some allowances for thermal expansion. In addition, it is undesirable to transmit excessive fixed stress or mechanical vibrations through the connecting leads to the cathode bushing. When handling or transporting the magnetron, the tube should never be supported by the cathode bushing.

It is considered good practice to install a capacitor in shunt with the heater, and as close to the heater terminals as possible. The capacitor prevents transient current surges from passing through the heater in the event of an arc. This capacitor must be capable of withstanding the maximum ambient temperature encountered by the cathode bushing. A suitable connector incorporating this capacitor as an integral part of the connector is the UCINITE No. 115364, manufactured by the United-Carr Fastener Corporation.

The rate of rise of the voltage pulse (rrv), or time of rise in microseconds, applied to the magnetron should be within the limits indicated in the Electrical Specification Sheets. An excessive rate of rise of voltage will tend to cause severe arcing and/or moding resulting in rapid tube deterioration. If the voltage rise is slow, the magnetron may operate under reduced-current conditions for an appreciable period and excessive frequency modulation within the pulse will result. The applied rrv is measured as the steepest slope of the leading edge of the voltage above the 50 percent level. It is essential that the total voltage variation across the top of a single pulse is less than 7.0% to insure a good r.f. spectrum. The trailing

\*For specific values refer to Electrical Specification Sheet.

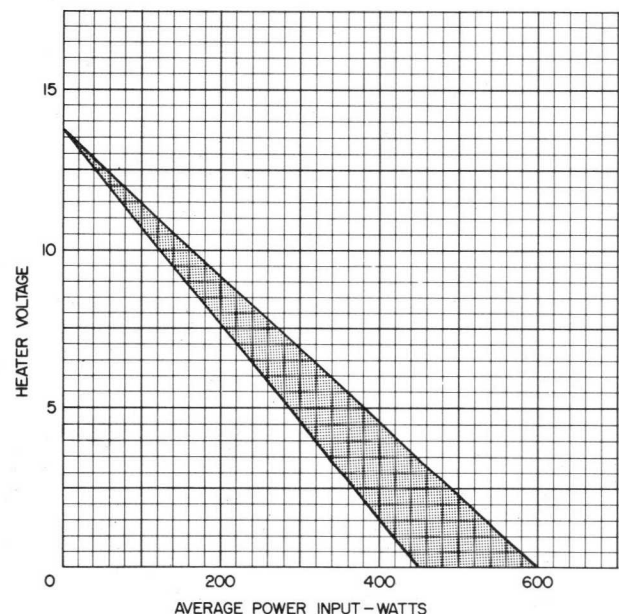

Figure 8—Recommended Heater Voltage Schedule. Shaded area indicates region of flexibility.

edge of the voltage pulse should decrease rapidly to produce the best frequency spectrum, while backswing after the pulse should be low enough to prevent the tube from breaking again into oscillation. It is preferable that measurements of the voltage pulse characteristics be evaluated on the actual system pulse applied to an operating magnetron. Laboratory modulators and/or dummy loads may produce a spectrum far different than that obtained under actual system conditions.

### LOAD CONSIDERATIONS

In a particular system application, the use of an electrically long transmission line between a magnetron and an unmatched load can cause frequency instability. This is known as the "long-line" effect and becomes a serious consideration during system design even for values of VSWR below 1.5:1. This long-line effect is dependent upon the Pulling Figure of the magnetron, the operating frequency, the type of transmission line, and the amplitude of the mismatch. The critical line length is shown graphically in Figure 9 for a pulling figure of 13.5 Mc.

The magnetron should always be operated into a load with a VSWR of less than 1.5:1. Larger values of VSWR can cause spectrum degradation or power loss which will, in turn, compromise good system performance. With the tube operated into a VSWR of 1.5:1, the operating frequency will be dependent upon the phase of mismatch. The maximum frequency deviation due to variations in the phase of this load is called the Pulling Figure, and is an important parameter of the test specification for the tube manufacturer. The Pulling Figure for a typical tube will vary between 9.0 Mc and 12.0 Mc depending upon the operating parameters. Power variations will also be encountered due to variation in the phase of a 1.5:1 VSWR, with the operating region for highest power occurring at the same phase that produces the maximum frequency rate of change. Typically experienced power variations under these conditions are from 175 kw to 250 kw.

The Rieke diagram is the usual method of describing the operation of the magnetron as the load is varied. In this diagram, contours of constant frequency and constant power output are plotted as function of phase and amplitude of load mismatch. Since the phase of reference for a Rieke diagram varies considerable for a tunable magnetron it cannot readily be used as a system design

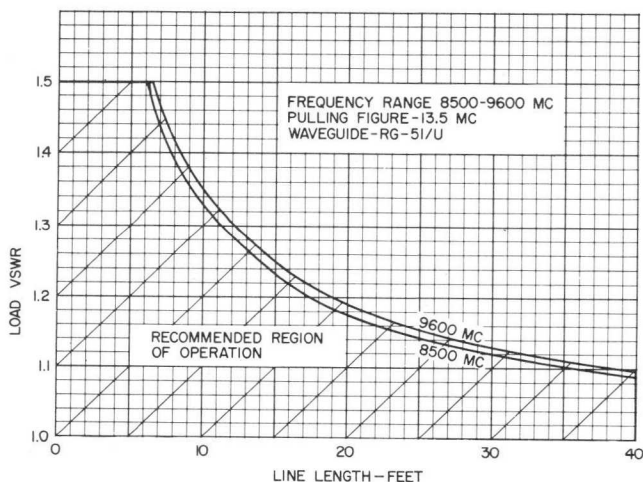

Figure 9—Effect of Length of Transmission Line on Allowable VSWR.

tool. It is recommended that a non-reciprocal attenuator, such as a ferrite isolator, be used in the system to maintain a low load VSWR and to eliminate the need for controlled line length.

### PERFORMANCE

**Typical performance curves** for the 7692A and M-4193A are shown in Figures 10 and 11. The peak power output, the required peak anode voltage and the operating efficiency are plotted in Figure 10 for a wide range of peak anode currents. It should be noted that these curves are for a particular set of operating conditions and the performance may vary slightly for different conditions of pulse width, duty cycle and load VSWR. Figure 11 depicts the typical variation in Peak Power Output and Peak Anode Voltage as the tube is tuned over the range.

**Jitter or frequency stability** is defined as a measure of the frequency change during a single pulse. Typical intra-pulse stability values for the 7692A are between 100 and 200 KC, while the interpulse time jitter is in the order of 10 nanoseconds.

**Cathode Memory—(Power Stability)**—One of the major problems associated with multi-pulse system operation is the ability of the magnetron to respond satisfactorily as it is switched between different pulse widths. Results obtained on a quantity of 7692A tubes examined for a time in excess of 700 hours have shown satisfactory performance with less than 0.5% missing pulses. Typical results of this test, during which the pulse widths were programmed to simulate system conditions, are shown in Figure 12. An improvement in this cathode memory characteristic can be obtained if the second pulse condition is preceded by a short period at reduced power. Cathode memory characteristics of the M-4193A are given in the Electrical Specifications Sheet.

**Pushing**—The frequency of SYLVANIA high power X-band tunable magnetrons is relatively unaffected by changes in anode current. The pushing characteristic for the 7692A is shown graphically in Figure 13. The normally experienced variations due to operating frequency are indicated by the shaded areas of the curves.

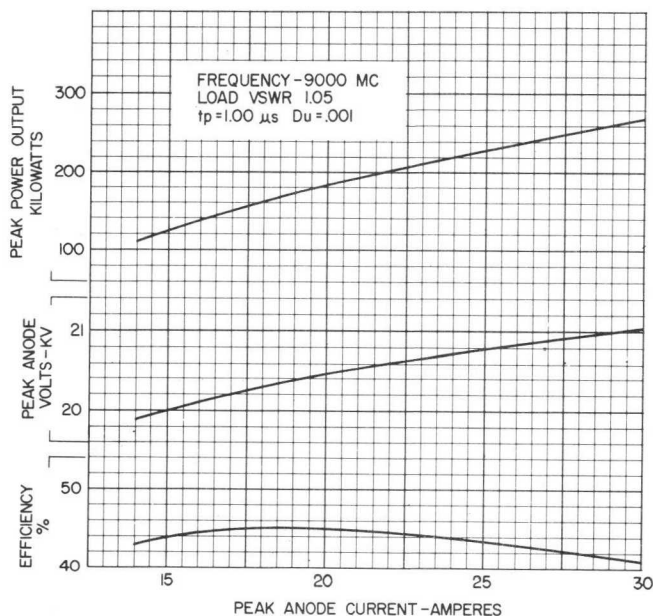

Figure 10—Typical Performance Curves for Sylvania 7692A and M-4193A.

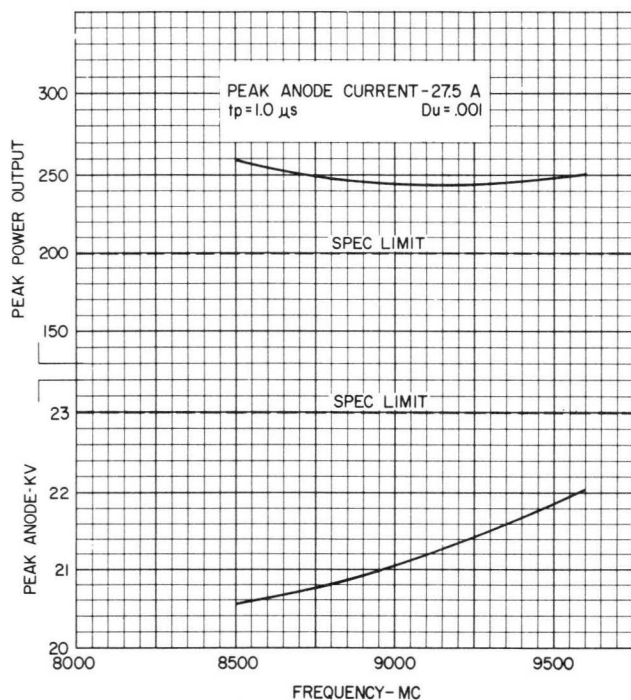

Figure 11—Typical Performance Curves for Sylvania 7692A and M-4193A.

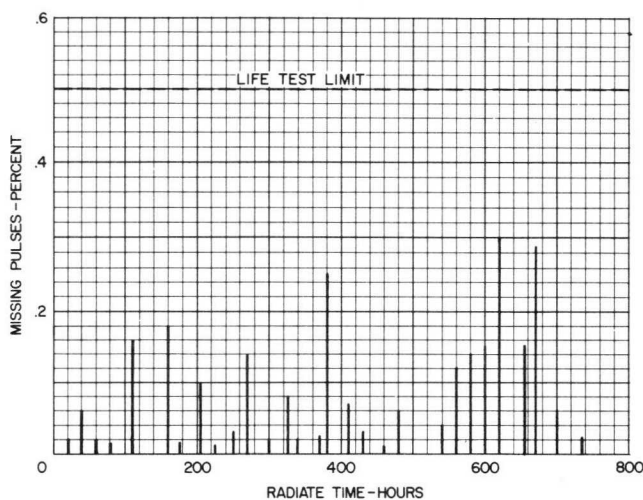

Figure 12—Cathode Memory, Typical Life Data for Sylvania 7692A

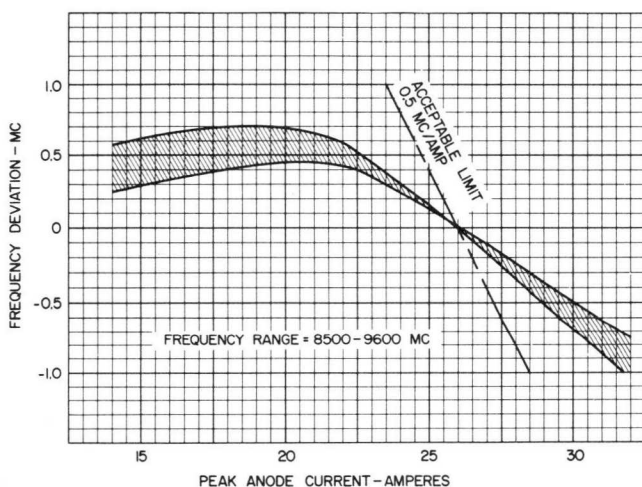

Figure 13—Typical Pushing Characteristics. Shading exemplifies typical range of variation with frequencies.

## TUNING

The tuner mechanism of SYLVANIA high power X-band tunable magnetrons has inherent and unique design features to provide controlled frequency adjustment that are not provided by competitive tuners. The "Inductive Pin Tuner" is a modification of the "crown-of-thorns" tuner and is characterized by (1) linear tuning, (2) relative freedom from vibrational resonances up to 500 cycles and (3) low thermal drift effects. The exceptional linearity of the tuning curve is shown in Figure 1. The 7692, 7692A and M-4193A tuner also exhibits an exceptionally low running torque of less than 6 in. oz. with typical starting torques of approximately 9 in. oz. A tuning backlash of less than 5 mc is attained at extreme limits of temperatures.

## LIFE

The operational life of the 7692A and M-4193A has been conservatively rated as 700 hours and typical results of prolonged testing indicate a high degree of reliability with negligible changes in electrical performance at 1000 hours. Reference is made to Figure 3 which shows the average output power versus life. Life test end points specified on the individual Electrical Specifications Sheet include requirements for spectrum characteristics, missing pulse stability and power output.

## HANDLING PRECAUTIONS

In the handling of magnetrons, the following precautions should be taken.

1. All tools and hardware used for the installation of tubes into a system or test bench must be of a material that is non-magnetic. The following types may be used: Non-magnetic stainless steel, brass, or beryllium copper.
2. At no time are tubes to be placed closer than 4 inches from magnetic material or 6 inches from another magnet. If system packaging requires closer spacing, the effect on tube performance should be discussed with the tube manufacturer.
3. Care is advised in the handling of magnetrons, such that magnetrons are never picked up or carried by the flexible leads, cathode capsule, or output flange. Unnecessary jarring of the tube should be avoided.
4. Shipping containers (outer carton and inner cradle) are so designed as to afford adequate protection from magnetic fields in all directions. It is recommended that magnetrons be stored in the original shipping container and be stored on shelves of non-magnetic material. If this is not done, the tube manufacturer is not responsible for the tube.
5. Precaution is urged in the close placement of watches and other delicate instruments to magnetrons, because of the magnetic field.
6. The specified warm-up time of the filament must be adhered to before high voltage is applied.

## CAUTION

High Power X-Band Tunable Magnetrons are operated at high pulsed voltages which are potentially dangerous to life. Care should be taken in the design of the system and of testing equipment to protect the operator from the possibility of contact with high voltage. The high voltage terminals on both the tube and the power supply should be suitably enclosed and protected with interlocking switches to break the primary circuit of the power supply whenever access to the equipment is required.



OUTLINE—M-4193A\*

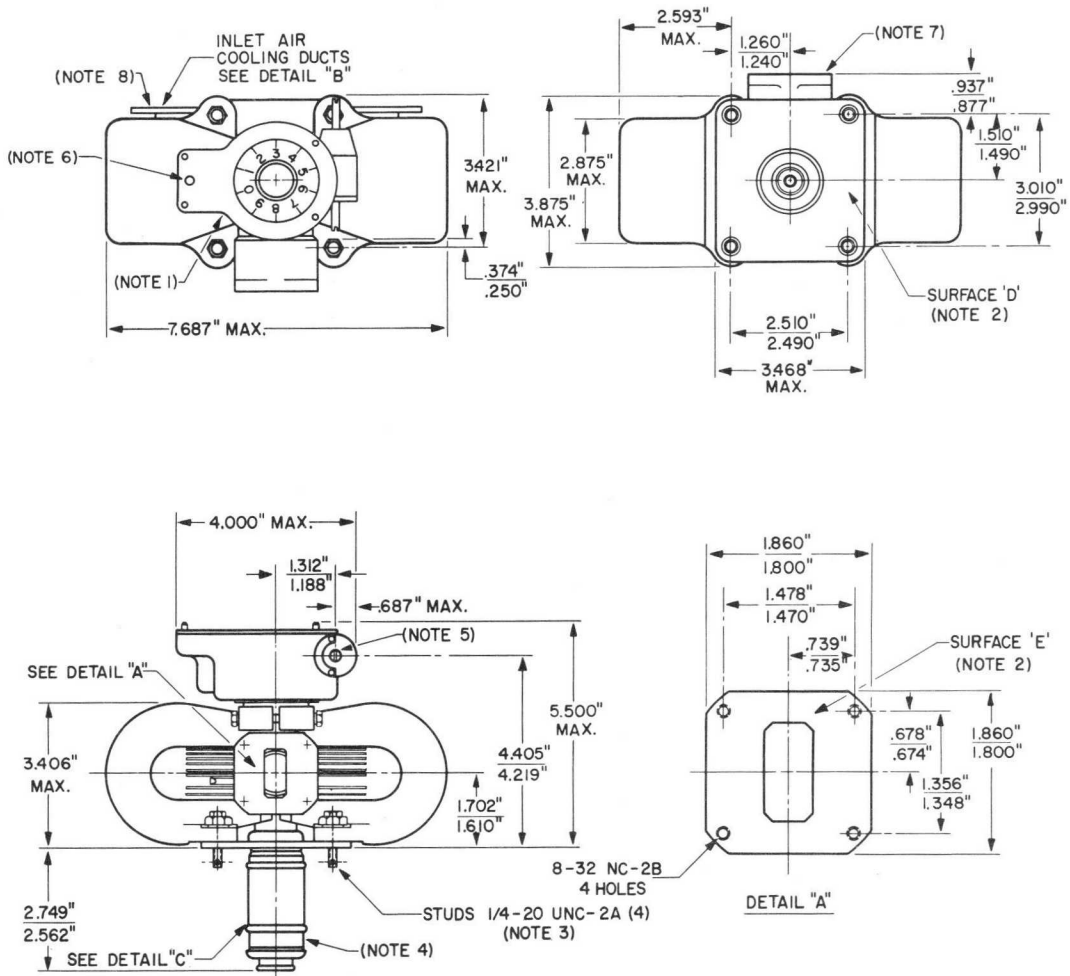

\*Variations between tube type are minor. Reference should be made to the specific EDS sheet for particular differences.

## OUTLINE—M-4193A\*

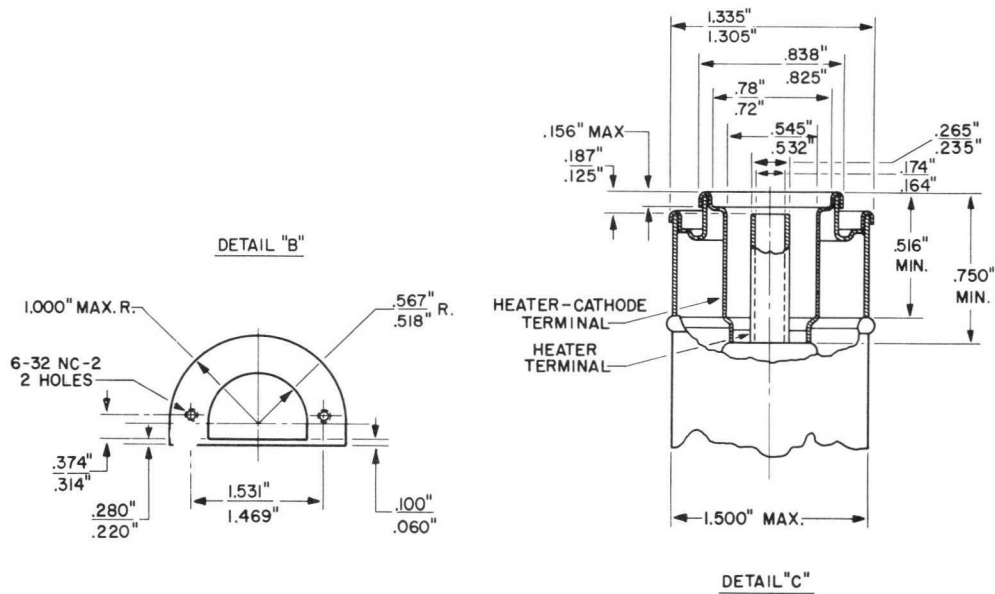

### DIAGRAM NOTES

1. Anode temperature to be measured at junction of waveguide and anode block.
2. Tolerance on surfaces "D" and "E" (waveguide output flange and mounting flange) shall be such as to permit a hermetic seal.
3. "NYLOCK" located 3 thds. from bolt end. Bolt material is non-magnetic and corrosion resistant.
4. Cathode temperature to be measured at this point.
5. Clockwise rotation, viewed toward output flange, decreases frequency.
6. Number registering here indicates number of complete revolutions of the worm gear from 0 to 11 inclusive.
7. The opening of the output flange shall be covered by a dust protector when tube is not in use.
8. The inlet air ducts shown are those normally supplied with the M4193A. These can be supplied with modifications at the customers option provided the maximum temperature limitations are not exceeded.





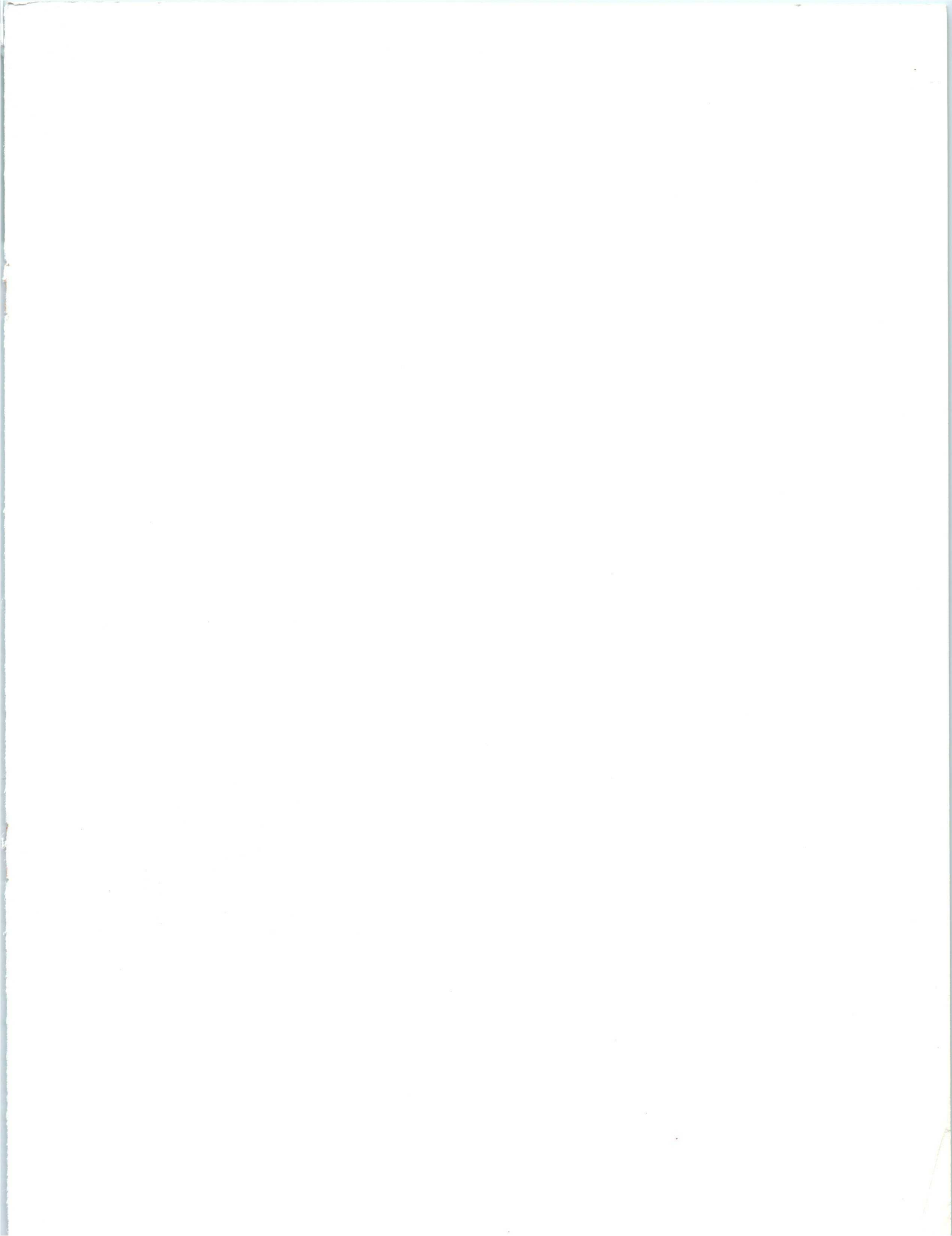



**SYLVANIA**  
SUBSIDIARY OF  
**GENERAL TELEPHONE & ELECTRONICS**

