

GENERAL POST OFFICE: E-IN-C (S)

Specification: G.P.O./CV.2324	SECURITY	
Dated: Issue 2 1st February 1960	<u>Specification</u>	<u>Valve</u>
To be read in conjunction with K 1001	Unclassified	Unclassified

→ indicates a change

<u>TYPE OF VALVE:</u> Air Blast cooled Tetrode		<u>MARKING</u>		
<u>CATHODE:</u> Directly heated. Thoriated Tungsten filament		See K 1001/4		
<u>ENVELOPE:</u> Copper/glass. Nickel/Iron/Cobalt/alloy.		Additional markings required (See Note B)		
<u>PROTOTYPE:</u> CR.176		Serial No..... Filament Volts 5.0		
<u>RATING</u>		NOTE	<u>BASE</u>	
Filament Voltage (V) 5.0		A. A.	See drawing, Page 3	
Filament Current (nominal) (A) 64.0			<u>CONNEXIONS</u>	
Max. direct anode voltage (kV) 7.5			See drawing, page 3.	
Max. anode dissipation (kW) 3.5			<u>DIMENSIONS</u>	
Max. screen grid dissipation (W) 200				See drawing, page 3
Max. control grid dissipation (W) 25				
Mutual conductance (mA/V) 8.25				
Inner amplification factor 4.4				
Peak usable emission (A) 10.0				
Max. frequency for above ratings (Mc/s) 30.0				
Air flow 350 c/f/minute at a pressure drop of 3 inches water gauge				
<u>CAPACITANCE. (pF)</u>			<u>PACKAGING</u>	
C (input) 40			See K 1005	
C (output) 14				
C a g 0.4				
<u>NOTE</u>				
A. Measured at $V_a = 3.0$ kV, $V_{g2} = 1500$ V, $I_a = 1.0$ A.				
B. It is not essential that the additional markings shall appear within the frame.				

CV 2324

TESTS

To be performed in addition to those applicable in K 1001

TEST CONDITIONS						TEST	LIMITS		NO. TESTED	NOTE
							MIN.	MAX.		
a	See K 1001/A/III					CAPACITANCES (pF)				
						Ca - all.	11	15	10%	
						Cg - all.	38	47		
b	V _f (V)	V _{g1} (V)	V _{g2} (V)	V _a (kv)	I _a (A)	I _f (A)	59	71	100%	2
	5.0	-	-	-	-					
c	5.0	3000	3000	3.0		I _e (A)	18	-	100%	3.2
d	5.0	Adjust	1500	4.0	1.0	I _{g2} (mA)	-	30	100%	2
						Rev. I _{g1} (μA)		32	100%	1.2
						V _{g1} (V)	-170	-260	100%	2
e	5.0	Adjust	1500	4.0	0.05	Rev. I _{g1} (μA)	-	20	100%	2
						V _{g1} (V)	-	-500	100%	2
f	5.0	Read	1500	3.0	0.75	g _m (mA/V)	7.5	9.0	100%	2
		Read	1500	3.0	1.25					
g		Read	1000	3.0	1.0	Inner μ				
		Read	1500	3.0	1.0		3.7	5.1	100%	2
h	5.0			6.0		OSCILLATION TEST (1) I _a (A)	1.2	1.6	100%	4.2
j	Repeat tests of I _{g1} in tests d and e. Difference in measurements to be < 5 μA. Repeat test c.									
k	5.0			6.0		OSCILLATION TEST (2)			T.A.	5
NOTES										
1. The I _{g1} test in test d shall be continued for 10 minutes and the value of I _{g1} shall not be rising at the end of the test period.										
2. Tests are to be carried out with the filament heated by 50 c.p.s. current, and all circuit returns shall be made to the centre tap on the filament transformer secondary. Air flow of 350 c/f/minute through radiator.										
3. Peak emission to be obtained by pulse method as outlined in K 1001 AV, or by other apparatus approved by the TYPE APPROVAL authority.										
4. Oscillation frequency = 0.5 Mc/s. V _{g2} = 0.75/1.25 kV, I _{g1} = 40/80mA, R _g = 6000 ohms. Oscillate for 20 minutes										
5. The Oscillation Test (2) shall be conducted at an oscillation frequency of 30 Mc/s in a circuit approved by the TYPE APPROVAL authority.										

DIMENSIONAL DIAGRAM

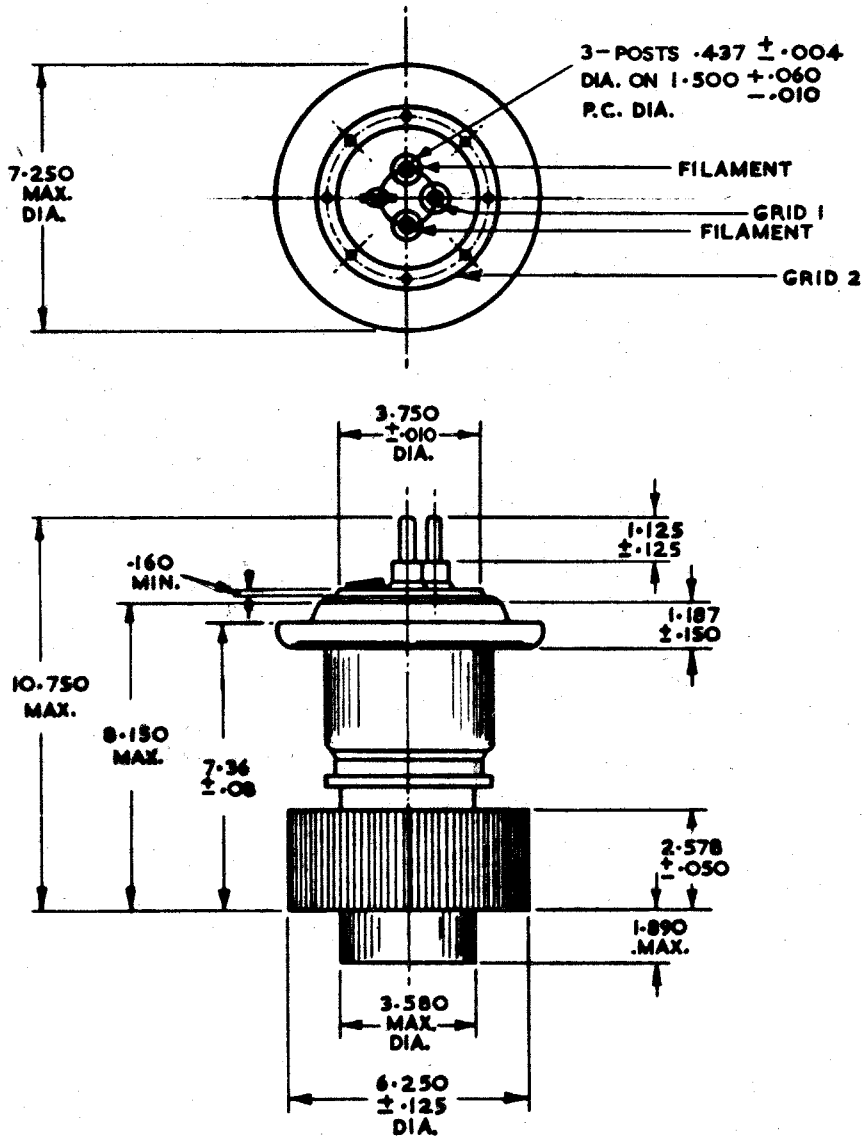

NOTE :- THE FINISH OF THE VALVE TO MEET THE REQUIREMENTS OF THE TYPE APPROVAL AUTHORITY

ALL DIMENSIONS IN INCHES