

VALVE ELECTRONIC **CV122**

MINISTRY OF SUPPLY (S.R.D.E.)

Specification: MCS/CV122/Issue 6 Dated:- 24.5.50 To be read in conjunction with K1001, ignoring clauses 4.1.1(a), 5.2, 5.8, 6.0, 7.1	<u>SECURITY</u>	
	<u>Specification</u> Restricted	<u>Valve</u> Unclassified

→ indicates a change

<u>TYPE OF VALVE:-</u> High - mu triode <u>CATHODE:-</u> Directly heated <u>ENVELOPE:-</u> Glass-unmetallised <u>PROTOTYPE:-</u> E.1336		<u>MARKING</u> See K1001/4. Additional Marking:- Colour Code (Note B)			
<u>RATING</u>		<u>BASE</u> None			
		Note			
Filament voltage (V)	1.5				
Max. filament current (A)	0.15				
Max. anode voltage (V)	100				
Mutual conductance (mA/V)	0.8	A			
Amplification factor	32	A			
Anode impedance (ohms)	40,000	A			
<u>NOTES</u>		<u>DIMENSIONS AND CONNECTIONS</u> See Fig. 1 and K1001/AI/D1			
A. Measured at $V_a = 100$ $V_g = 0$ B. A GREEN mark shall appear adjacent to the anode lead and the numbering shall be in GREEN		Dimension	Min	Max	
		A	mm	-	33
		B	mm	-	10
		Pip Length	mm	-	6
		<u>PACKAGING</u> See K1005			

TESTS

To be performed in addition to those applicable in K1001

	Test Conditions			Test	Limits		No. Tested	Note
					Min.	Max.		
a	Vf	Va	Vg	If (A)	-	0.15	0.1% (10)	
	1.5	-	-					
b	1.5	90	-	Gain test	20.0	25.5	100%	1,2,3
	Ra = 0.5 Megohm Rg = 1.0 Megohm							
c	2.0	90	-	Gain test	20.0	25.5	100%	1,2,3
	Ra = 0.5 Megohm Rg = 1.0 Megohm							
d	0	140	0	Leakage (μA) Anode to all	-	0.75	100%	
	0	0	140	Grid to all	-	0.75	100%	
e	1.5	140	-2	Gas current (μA)	-	1.0	100%	4

NOTES

1. This test shall be carried out in an approved circuit.
2. Filament voltage applied through a 5.5 ohm resistor, the grid to be returned to the negative end of the resistor.
3. 0.22 megohm resistor to be inserted in series with the applied signal and between the 1.0 megohm resistor and the grid.
4. Maximum time delay 0.75 secs.

SPECIAL REQUIREMENTS

1. The valves are required for embodiment into receivers and for short period operation. They are not required for replacement or normal life.
2. The valves are required to have a long life in storage and shall meet the requirements of these tests after a holding period of not less than one month from the date of initial test.
3. Owing to the mechanical requirements of the valves, the materials used and the methods of manufacture shall conform to the Material and Inspection Schedules. These Schedules shall form part of this specification, and may be obtained from C.I.E.M.E.
4. A description of the Production Details, which may be obtained through the type approving authority or their representative, is issued as an appendix to this specification. This shall not be regarded as a rigid specification, but the representative of the type-approving authority shall be informed within twenty-four hours of any deviations from the methods described therein and the "lot" numbers concerned. The type-approving authority may call for samples, for comparison with the original samples for which type-approval has been given.

FIG.1

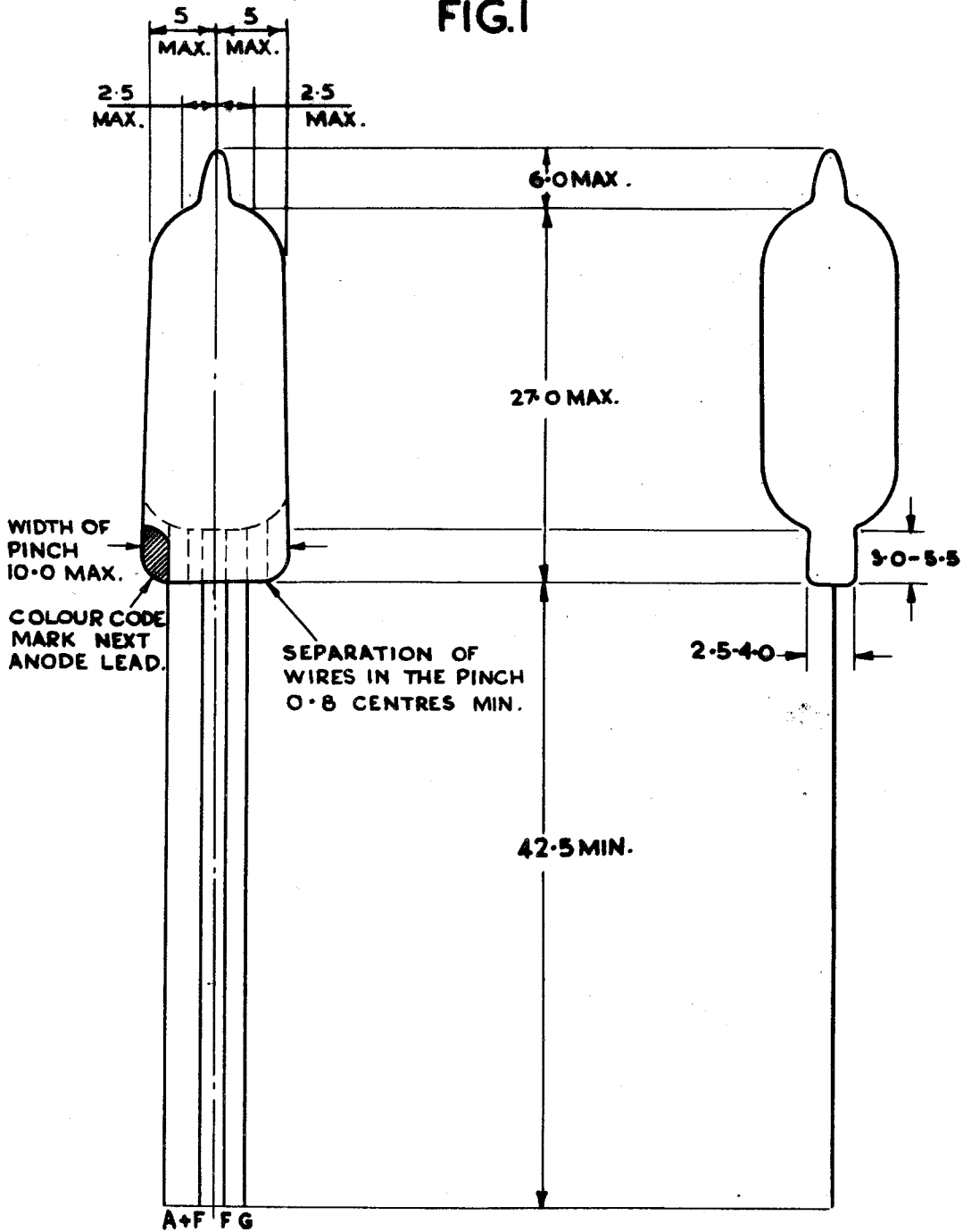

ALL DIMENSIONS IN MMS.
 SHAPE SHOULD BE APPROX. AS DRAWING.