



PHILIPS

cathode-ray tubes

for measuring equipment

PHILIPS ELECTRONIC TUBE DIVISION

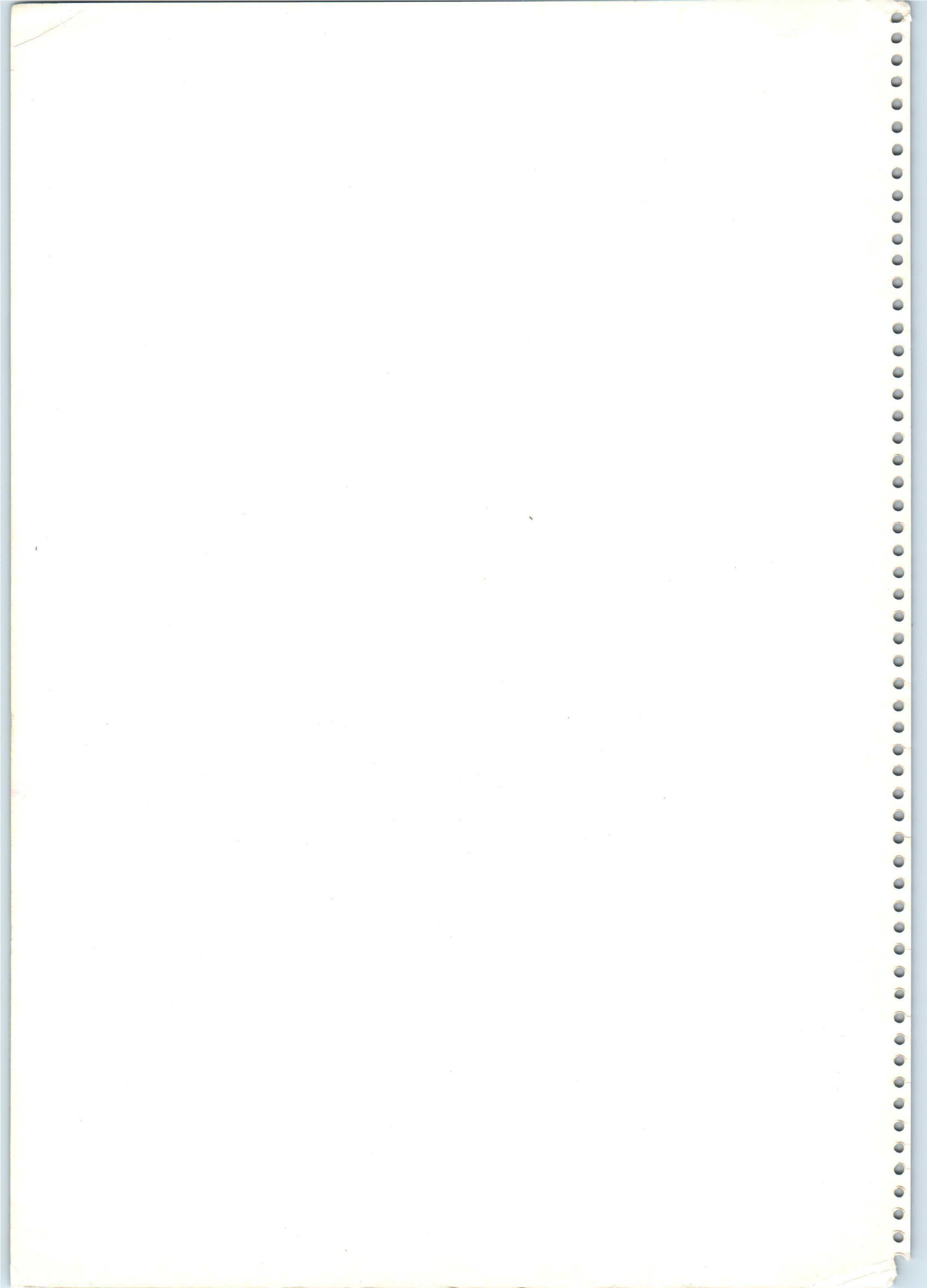



PHILIPS

Cathode-ray tubes

for measuring equipment

How **PHILIPS** cathode-ray tubes are made

The electron gun structure is assembled to close dimensional tolerances with the aid of special jigs and spacers. A ceramic cement is used to fix each part in position.

The manufacture of cathode ray tubes is an industry which involves a wide variety of processes and techniques, the use of intricate and ingenious automatic machines, and great skill and dexterity on the part of operators. In the next few pages a description is given of the manufacturing process, illustrated by a selection of photographs taken in the cathode-ray tube works.



First of all the many different component parts of the tubes have to be made to very close dimensional tolerances and from materials of the highest purity. These include nickel cathodes, coated with special emissive material; heaters, made from fine tungsten wire and insulated with alundum; beam forming and deflection electrodes, made from special non-magnetic material; ceramic supports upon which the electrodes are mounted and glass parts of various shapes. After manufacture every component is accurately gauged and inspected.

The components are then chemically cleaned and heat-treated before they are issued to the assembly department. In the assembly shop, where a high standard of cleanliness is maintained,



Supports for the heater-cathode assembly are aligned with tweezers. To produce clean and sturdy joints welding is done in an atmosphere of inert gas.



The electrode assembly is welded to the lead-in wires.

specialty trained, skilled girls assemble the electrodes on the supporting rods, using ingenious jigs and spacing pieces to ensure that each electrode is correctly located. A liquid ceramic cement is then applied to secure each component in position. At this stage certain internal joints and connections are made by electric spot welding, the parts to be joined being first manipulated into position with tweezers.

The next stage is to join the electrode assembly to the glass mount into which are moulded the necessary lead-in wires. These wires are themselves of a complex nature, for they consist of an upper portion of stout nickel wire to which the electrode system is welded, a lower portion of high conductivity copper wire which is later soldered to the appropriate contact pin in the base, and a short central portion made from a special metal having the same coefficient of expansion as the glass, so that it forms a vacuum-tight seal at the point where the wire passes through the glass mount. The mount also carries a central glass tube through which the air is withdrawn from the bulb during the pumping process.

The assembly is now carefully inspected. Its overall dimensions and the interelectrode clearances are checked; all welded joints are tested, and any errors in alignment are rectified.

Meanwhile the bulbs or envelopes have been prepared to receive the electrode assemblies. Blown from special quality glass, by complicated automatic machines, the bulbs are carefully annealed to normalize any internal stresses set up during the blowing process. Next, each bulb is washed continuously for a considerable time with a powerful acid, rinsed many times with



Pumping and sealing off is done on an intricate automatic machine. During the pumping process the tubes pass through several phases of normal and high-frequency heating to remove the last traces of gas.

distilled water and carefully dried. This treatment ensures that the bulb contains no foreign substance which could contaminate and spoil the fluorescent screen which is later deposited on the inner surface of the flattened end of the bulb.

The application of the fluorescent screen is a highly skilled and delicate operation. The fluorescent material, in the form of a fine powder, is mixed with a liquid binding agent to a thin paste. An accurately measured quantity is poured into the bulb, a deft twist of the hand ensuring that it is evenly distributed over the flat end of the bulb. Some types of screen require a different process, according to which the material is settled from a liquid in which it has been dispersed previously together with the required binding agents. After settling the liquid is poured off. The

inner surface of the sides of the conical portion are then coated with colloidal graphite, forming a conductive layer. The bulb is then placed in an oven where the coating is baked on and the volatile binding agent evaporated from the screen.

Now the electrode assembly is inserted into the neck of the bulb, spring lugs on the pre-deflection accelerator making a good connection between this electrode and the internal conductive coating. The whole is next mounted in a machine where gas and oxygen flames heat the neck of the tube in such a way that the glass mount and the tube neck soften and fuse together. With the electrodes thus sealed into the envelope, the only connection between the inside of the envelope and the outer air is through the thin pumping tube. The cathode ray tubes are then mounted on a rotating table, their pumping tubes being connected to special pumps which withdraw the air out of the bulbs. While being pumped the tubes pass through a tunnel which is strongly heated to help drive off the air and other gases. During other phases of the pumping process the metal parts in the tube are high-frequency heated to drive out gases trapped in the metal. The pumping tube is now sealed off, and the completed tubes removed from the pumping table. The getter — a chemical material previously attached to the electrode assembly — is then volatilised by high-frequency heating and absorbs the last traces of gas, thus forming a vacuum of a very high order.

It only remains to fit the base and solder the base connections, to submit the tubes to an ageing process and to conduct the stringent factory tests. The tubes then pass to the finishing benches where the type number and other markings are etched on the tube after which they are given a final inspection before being packed in their fall proof cartons.

For sealing the electrode assembly in the bulb the systems are placed on a rotating sealing machine, where gas and oxygen flames fuse the bulb and the glass bottom of the electrode system together.



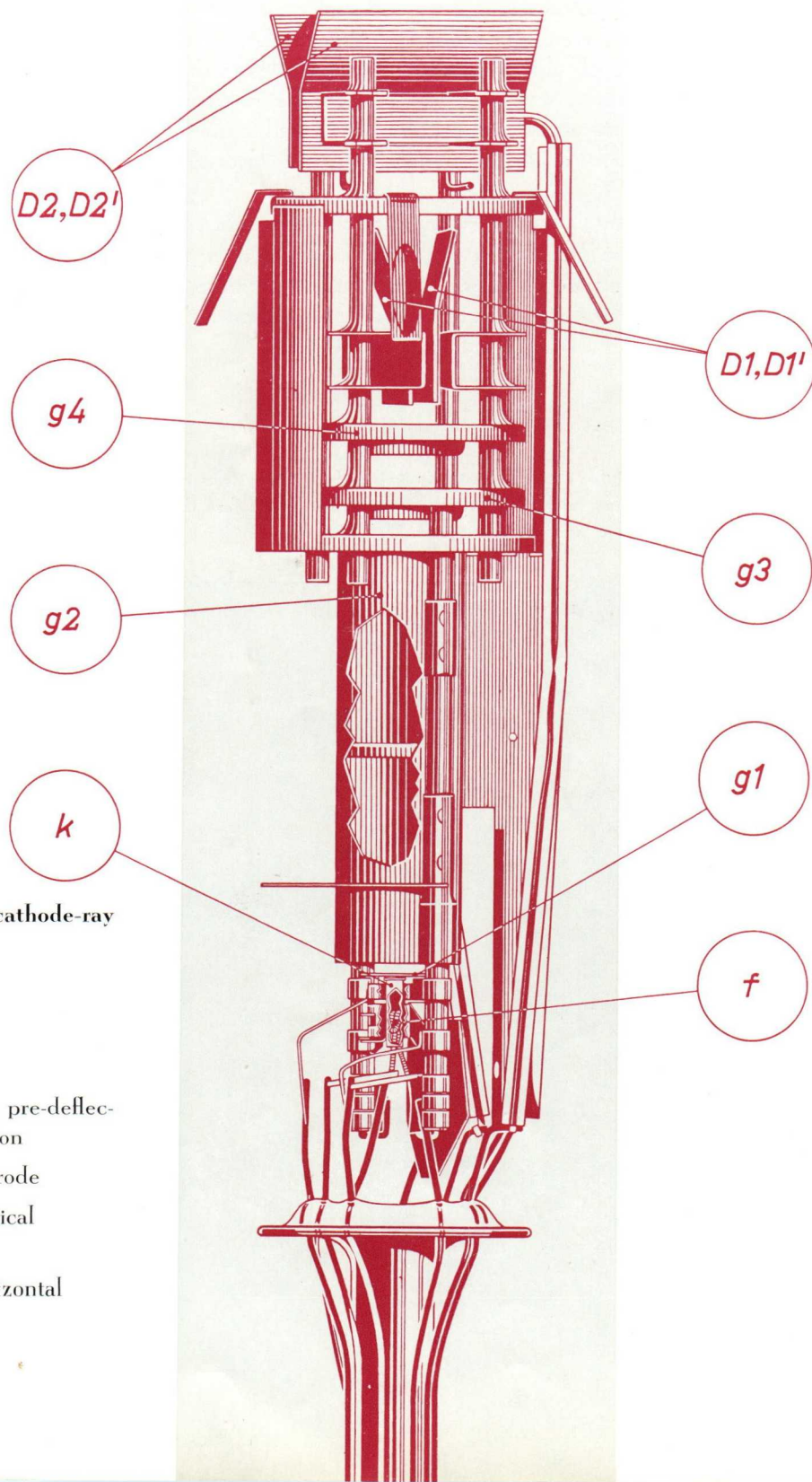

Electron gun of the cathode-ray tube DG 13-2.

- f - heater
- k - cathode
- g₁ - control grid
- g₂, g₄ - electrodes for pre-deflection acceleration
- g₃ - focusing electrode
- D₁, D₁' - plates for vertical deflection
- D₂, D₂' - plates for horizontal deflection



Fundamental screen characteristics

To cover all practical requirements of normal oscillography the cathode-ray tubes dealt with in this Bulletin are available with different screen types, of which full particulars are given on the following pages. The type of screen is indicated by the second letter of the type number; for example tube type DG 7-5 is provided with a G-screen. The various screens differ as to colour of the fluorescence (spectral energy distribution), persistence after removal of the electron beam and brightness for a given combination of specific screen current and accelerating voltage. Of each screen a curve is given for the relative spectral energy distribution, which is indicative for the colour of the fluorescence. There is one screen with long persistence, type P, in which two layers of different composition are used. With this screen the colour of the afterglow, occurring after removal of the electron beam, is determined by the screen nearest to the tube face, this colour being different from that obtained during continuous electron bombardment of the screen.

Another important screen characteristic is the persistence of the luminescence. A curve is given for each screen of the relative decay of the brightness after the electron beam is removed.

Finally, the brightness is indicated as a function of the specific screen current for different values of the accelerating voltage. Attention should be drawn to the fact that the screen current is always less than the current flowing in the pre-deflection accelerator lead, part of the beam current being intercepted by this electrode. The ratio of screen current to pre-deflection accelerator current can be determined from the control curves given with each type of cathode-ray tube. For tubes with post-deflection acceleration and a given screen current the post-deflection accelerator voltage is decisive for the brightness obtained. Such tubes can also be used without post-deflection acceleration, the two accelerator electrodes then being interconnected externally.

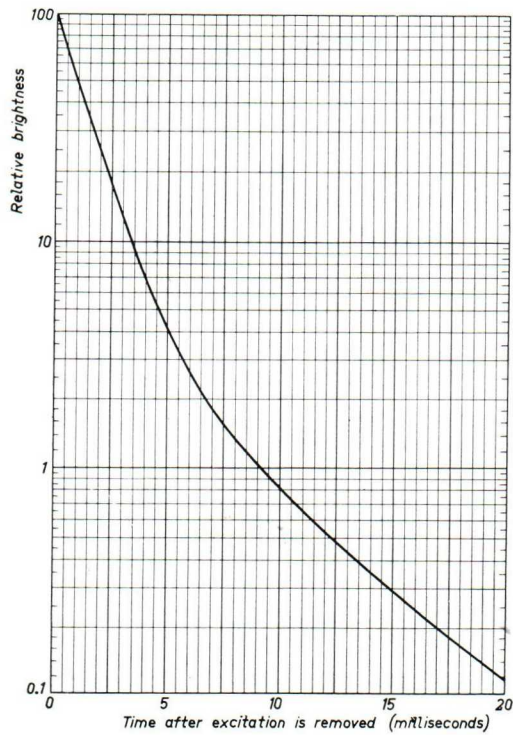

Persistence characteristic of a B-screen.

The B-screen gives a blue fluorescence, which is specially suitable for photographic recording purposes. It has a very short persistence, the relative brightness decreasing to 0.1 % within 20 milliseconds after removal of the electron beam.

B-screen

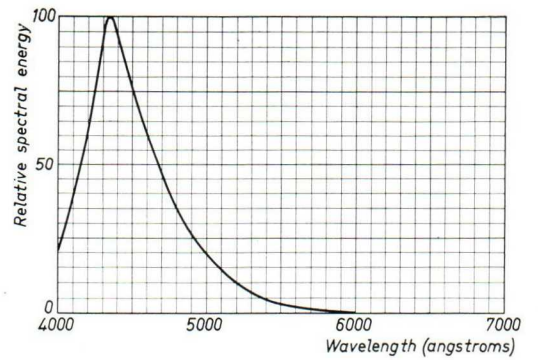

Relative spectral energy distribution of a B-screen.

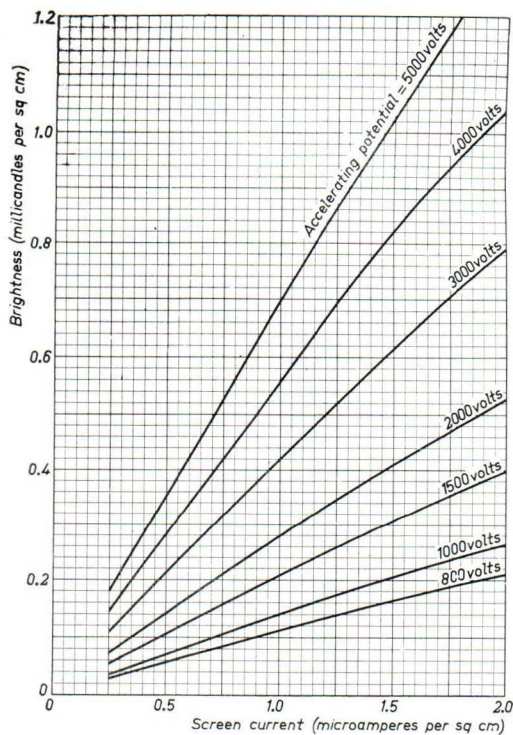

Brightness of a B-screen as a function of the screen current per square cm screen area, with the accelerating potential as a parameter.

The green fluorescent G-screen provides high visual contrast under conditions of normal ambient illumination. It has medium persistence and can be used for visual observation of recurrent phenomena in the majority of applications.

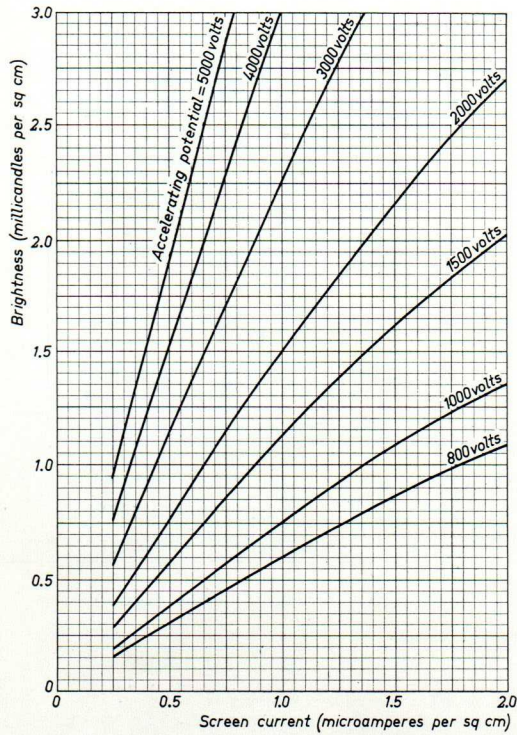

Relative spectral energy distribution of a G-screen.

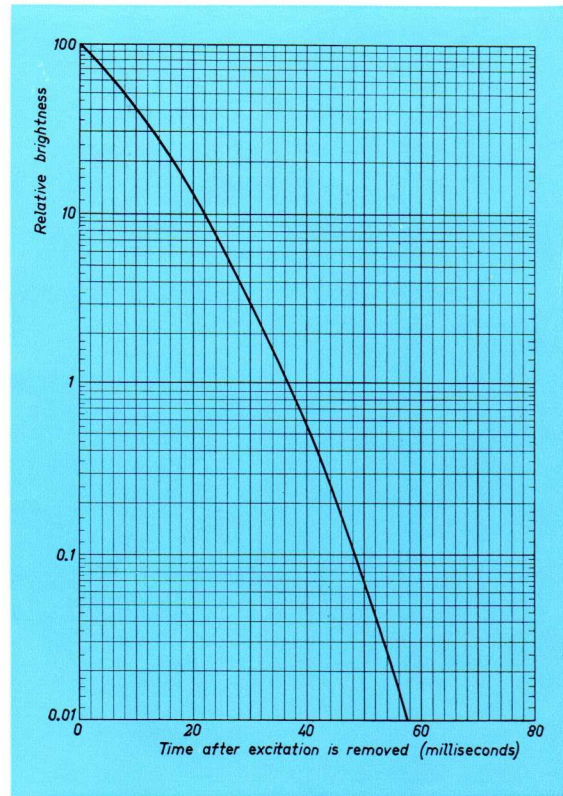
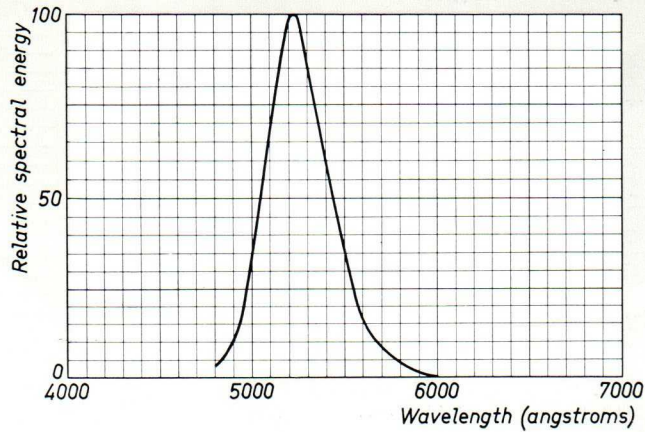

Persistence characteristic of a G-screen.

G-screen

Brightness of a G-screen as a function of the screen current per square cm screen area, with the accelerating potential as a parameter.

R-screen

The R-screen has long persistence and greenish-yellow fluorescence. It is suitable for observation of non recurrent phenomena and may also be used in cases where recurrent phenomena of very low frequency must be observed.

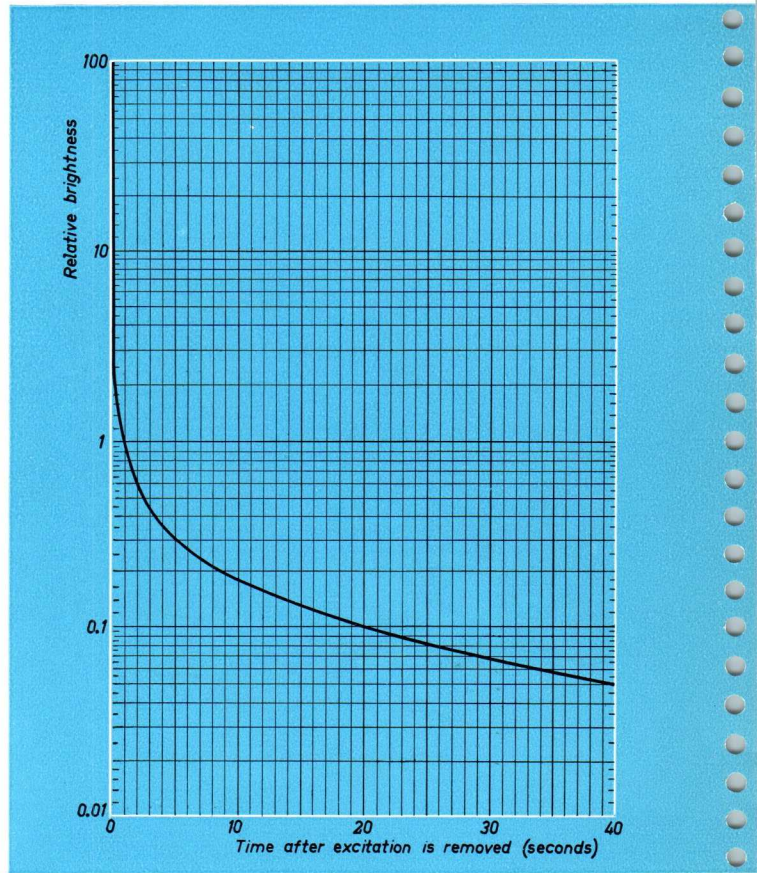

Persistence characteristic of an R-screen.

Brightness of an R-screen as a function of the screen current per square cm screen area, with the accelerating potential as a parameter.

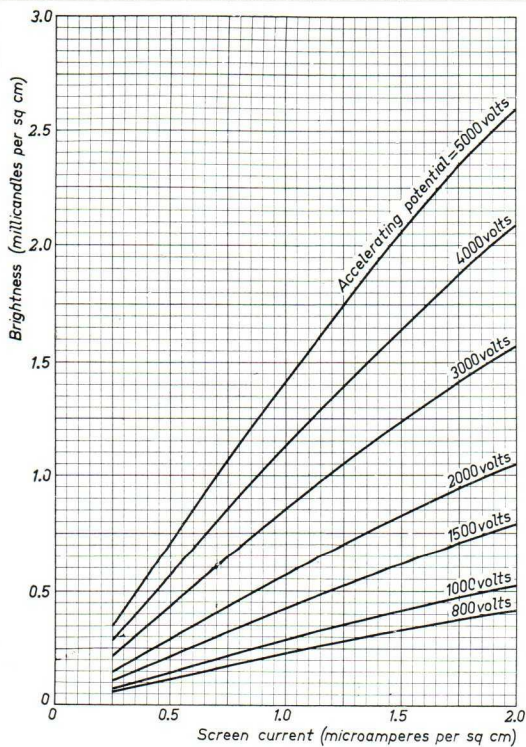

Relative spectral energy distribution of an R-screen.

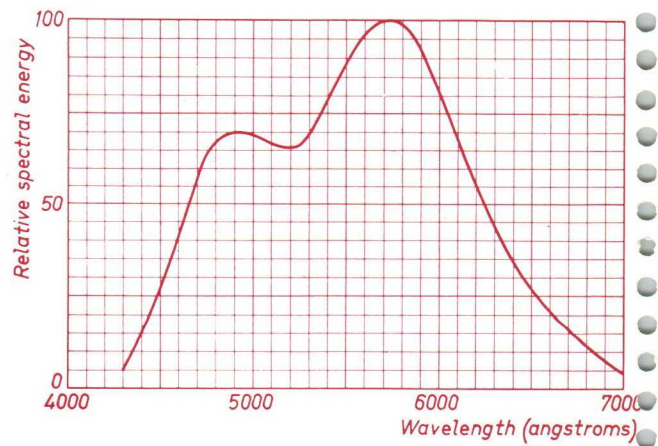

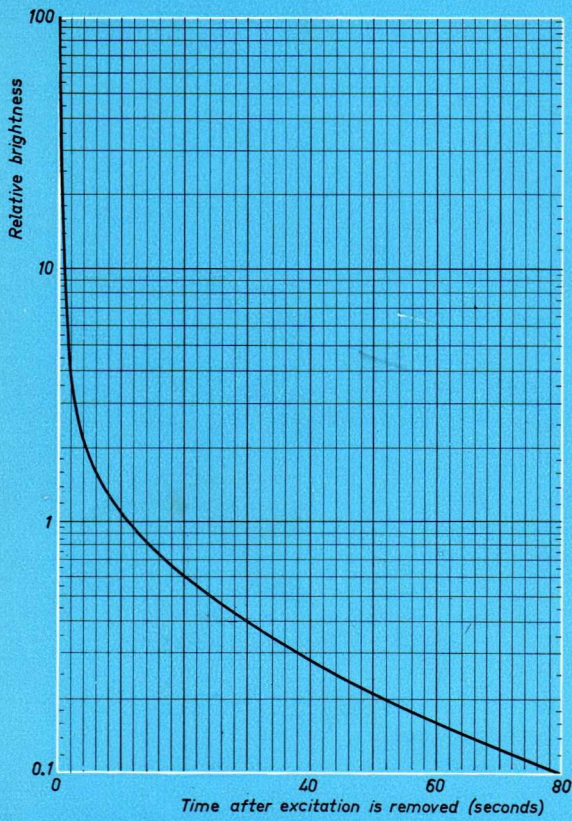

Persistence characteristic of a P-screen.

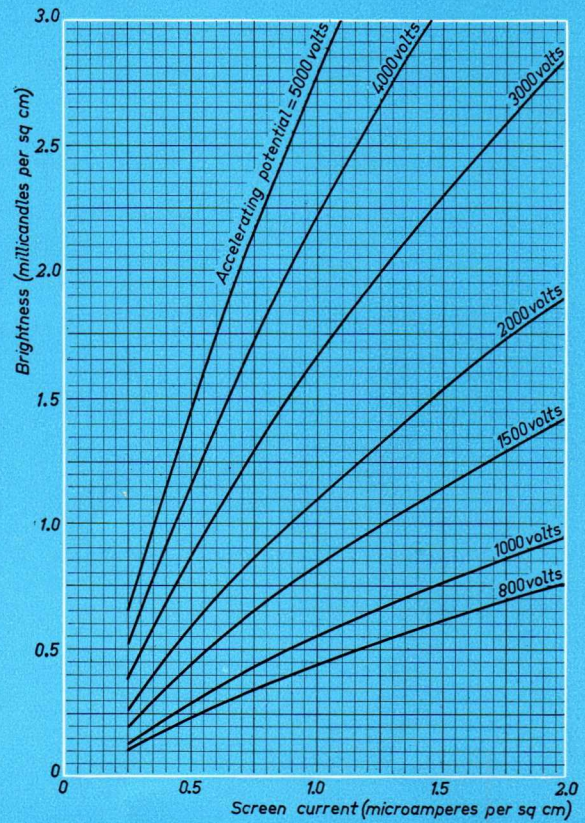

Brightness of a P-screen as a function of the screen current per square cm screen area, with the accelerating potential as a parameter.

P-screen

The P-screen consists of two different layers, the layer nearest to the electron gun exciting the layer deposited directly on the tube face, the latter having a very long persistence. During excitation the colour of the fluorescence is blue-ish, whereas the afterglow has a greenish-yellow colour. This screen is specially suitable for observation of non recurrent phenomena.

Relative spectral energy distribution of a P-screen.

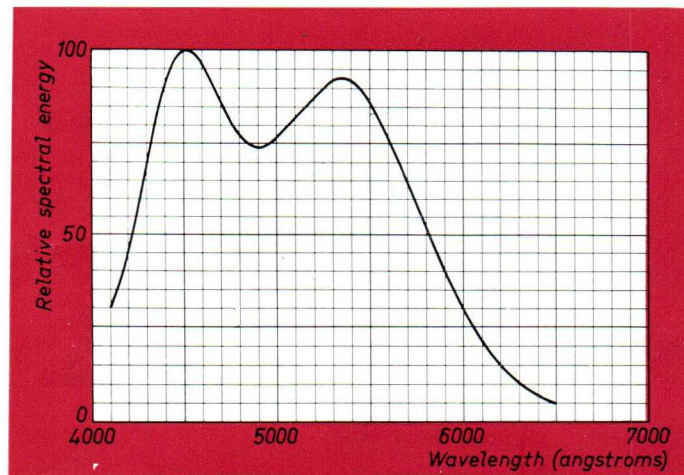

DATA OF CATHODE-RAY TUBES

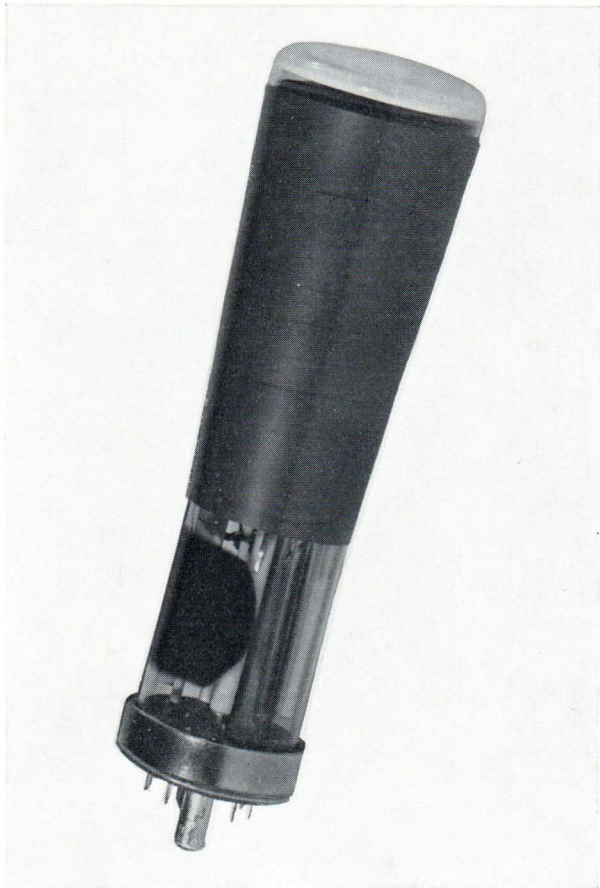

Heating

Indirect by A.C. or D.C.

Heater voltage 6.3 V

Heater current 0.51 A

Focusing

Electrostatic

Deflection

Double electrostatic

Deflection plates D_1D_1' for symmetrical drive

Deflection plates D_2D_2' for asymmetrical drive

(deflection plate D_2' should be connected to the accelerator (grid No. 3), for which earthing is recommended)

Line width

(measured with concentric circular deflection of 50 mm diameter, grid No. 3 voltage 800 V and screen current $0.5 \mu\text{A}$)

0.7 mm

Capacitances

D_1 to all other electrodes except D_1'

5.5 pF

D_1' to all other electrodes except D_1

5.5 pF

D_2 to all other electrodes except D_2'

4.5 pF

D_2' to all other electrodes except D_2

4.5 pF

Between D_1 and D_1'

0.6 pF

Between D_2 and D_2'

0.8 pF

Between D_1D_1' and D_2D_2'

0.1 pF

Grid No. 1 to all other electrodes

10 pF

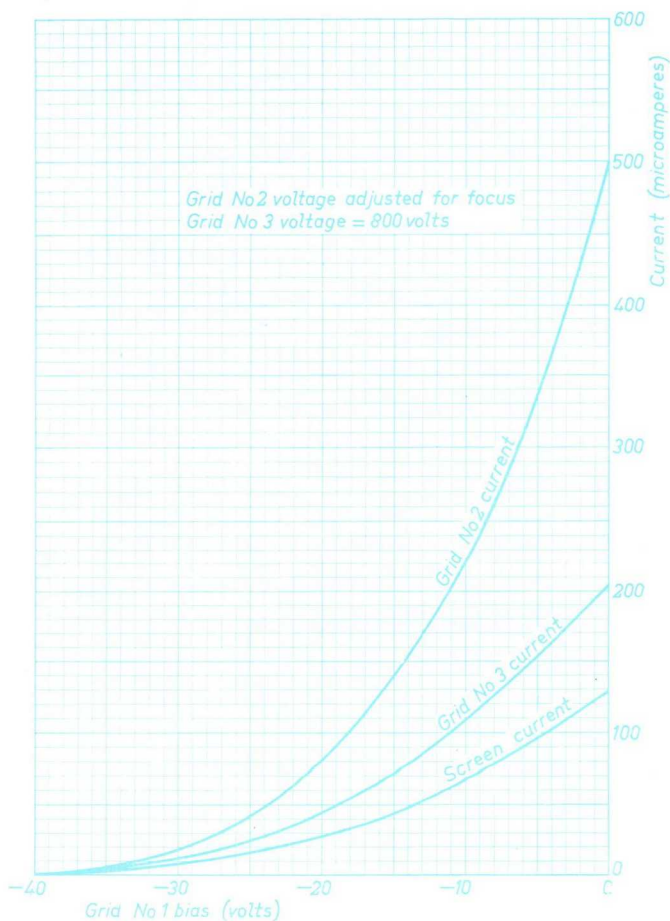

DB 4-2

DG 4-2

DP 4-2

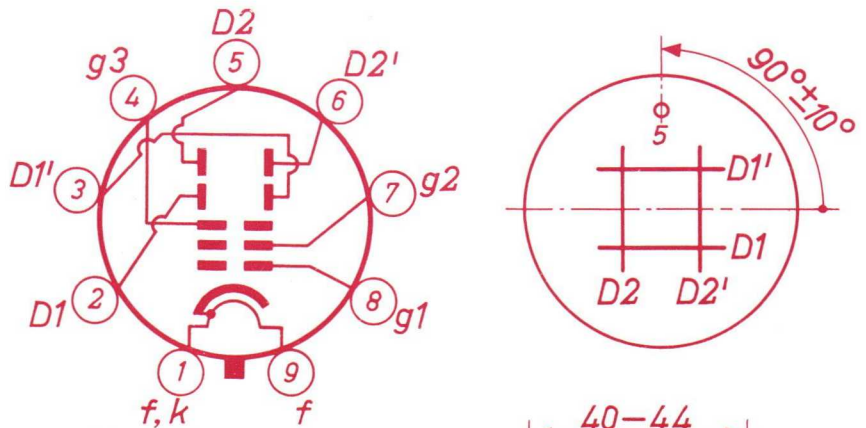

Typical operation

Accelerator (grid No. 5) voltage	800 V
Focusing electrode (grid No. 2) voltage	200–300 V
Maximum grid No. 1 bias for visual cut-off	–50 V
Deflection sensitivity plates D_1D_1'	0.25 mm/V
Deflection sensitivity plates D_2D_2'	0.16 mm/V

Ratings

Accelerator (grid No. 5) voltage, maximum	1000 V
Accelerator (grid No. 5) voltage, recommended minimum	800 V
Accelerator (grid No. 5) dissipation, maximum	0.5 W
Focusing electrode (grid No. 2) voltage, maximum	400 V
Grid No. 1 voltage	
positive-bias value, maximum	0 V
negative-bias value, maximum	100 V
Peak voltage between deflection plates D_1D_1' , maximum	450 V
Peak voltage between deflection plates D_2D_2' , maximum	750 V
Screen dissipation, maximum	5 mW/cm ²
Resistance in any deflection plate circuit, maximum	5 MΩ
Grid No. 1 circuit resistance, maximum	0.5 MΩ

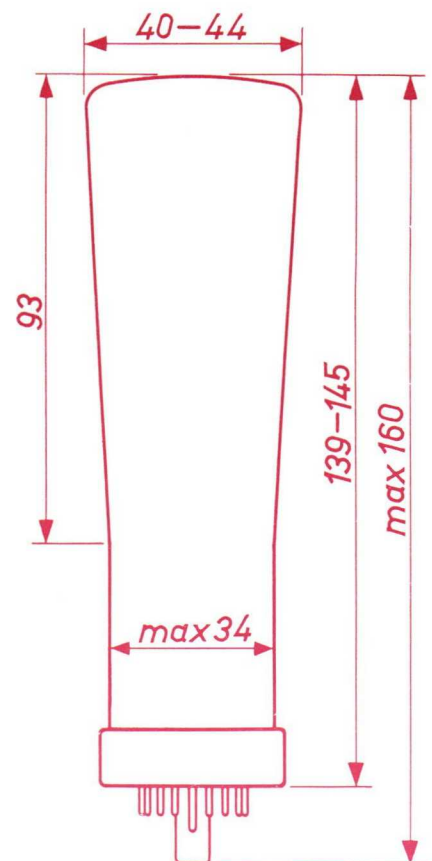

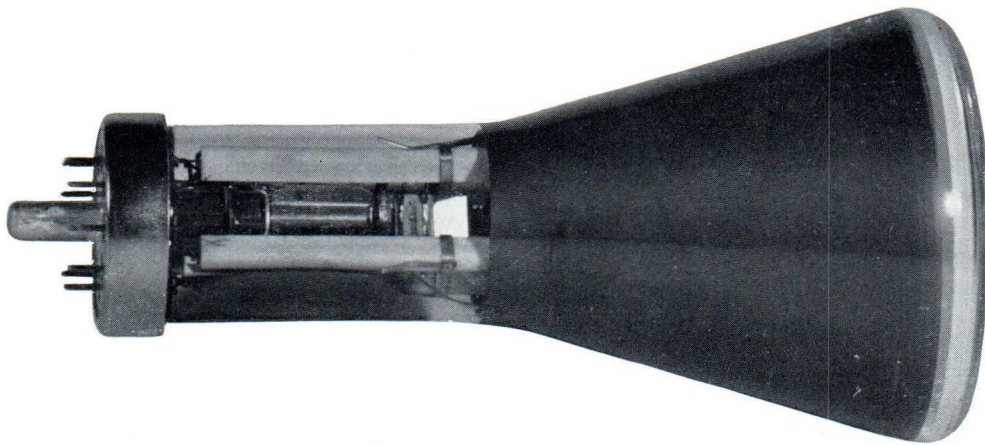

DB 7-5

DG 7-5

DP 7-5

DR 7-5

Heating

Indirect by A.C. or D.C.

Heater voltage 6.3 V

Heater current 0.31 A

Focusing

Electrostatic

Deflection

Double electrostatic

Deflection plates D_1D_1' and D_2D_2' for symmetrical drive

Line width

(measured with concentric circular deflection of 50 mm diameter, grid No. 3 voltage 800 V and screen current 0.5 μ A)

0.7 mm

Capacitances

D_1 to all other electrodes except D_1'

5.5 pF

D_1' to all other electrodes except D_1

5.5 pF

D_2 to all other electrodes except D_2'

4.5 pF

D_2' to all other electrodes except D_2

4.5 pF

Between D_1 and D_1'

0.6 pF

Between D_2 and D_2'

0.8 pF

Between D_1D_1' and D_2D_2'

0.1 pF

Grid No. 1 to all other electrodes

10 pF

DB 7-6**DP 7-6****DG 7-6****DR 7-6****Heating**

Indirect by A.C. or D.C.

Heater voltage 6.5 V

Heater current 0.51 A

Focusing

Electrostatic

Deflection

Double electrostatic

Deflection plates D_1D_1' for symmetrical driveDeflection plates D_2D_2' for asymmetrical drive(deflection plate D_2' should be connected to the accelerator (grid No. 5), for which earthing is recommended)**Line width**(measured with concentric circular deflection of 50 mm diameter, grid No. 5 voltage 800 V and screen current 0.5 μ A)

0.7 mm

Capacitances D_1 to all other electrodesexcept D_1' 5.5 pF D_1' to all other electrodesexcept D_1 5.5 pF D_2 to all other electrodesexcept D_2' 4.5 pF D_2' to all other electrodesexcept D_2 4.5 pFBetween D_1 and D_1' 0.6 pFBetween D_2 and D_2' 0.8 pFBetween D_1D_1' and D_2D_2' 0.1 pF

Grid No. 1 to all other electrodes 10 pF

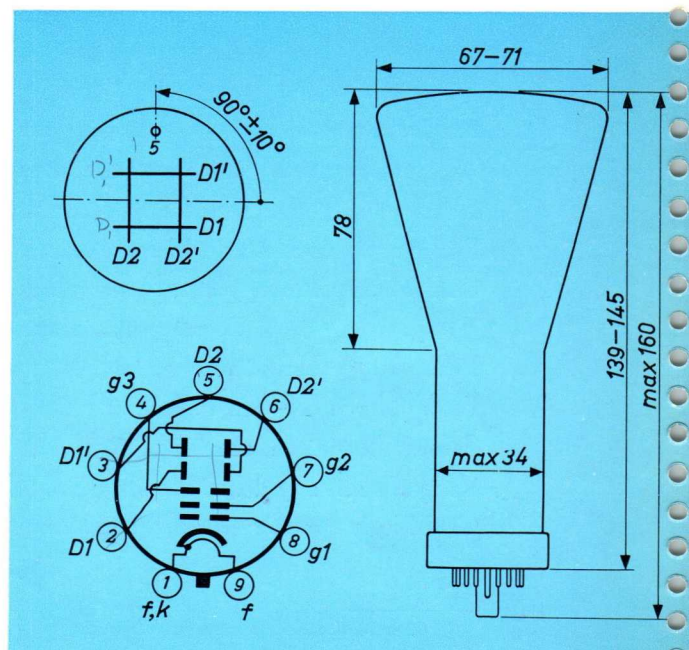

Typical operation

Accelerator (grid No. 3) voltage	800 V
Focusing electrode (grid No. 2) voltage	200–300 V
Maximum grid No. 1 bias for visual cut-off	–50 V
Deflection sensitivity plates D_1D_1'	0.25 mm/V
Deflection sensitivity plates D_2D_2'	0.16 mm/V

Ratings

Accelerator (grid No. 3) voltage, maximum	1000 V
Accelerator (grid No. 3) voltage, recommended minimum	800 V
Accelerator (grid No. 3) dissipation, maximum	0.5 W
Focusing electrode (grid No. 2) voltage, maximum	400 V
Grid No. 1 voltage positive-bias value, maximum	0 V
negative-bias value, maximum	100 V
Peak voltage between deflection plates D_1D_1' , maximum	450 V
Peak voltage between deflection plates D_2D_2' , maximum	750 V
Screen dissipation, maximum	5 mW/cm ²
Resistance in any deflection plate circuit, maximum	5 M Ω
Grid No. 1 circuit resistance, maximum	0.5 M Ω

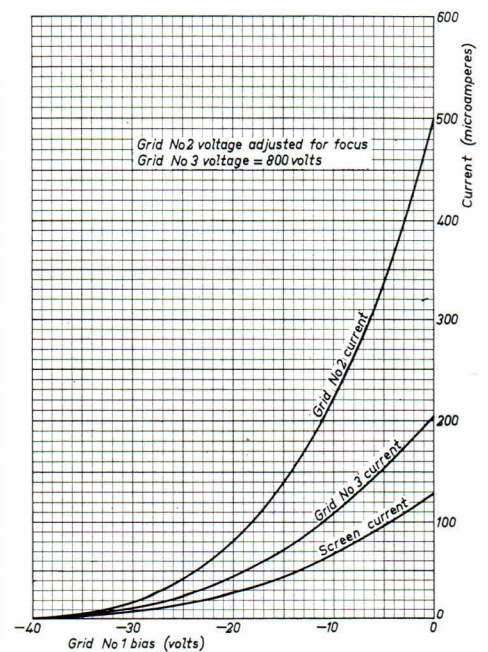

DB10-2**DG10-2****DP 10-2****DR10-2****Heating**

Indirect by A.C. or D.C.

Heater voltage 6.3 V

Heater current 0.3 A

Focusing

Electrostatic

Deflection

Double electrostatic

Deflection plates D_1D_1' and D_2D_2' for symmetrical drive**Line width**(measured with concentric circular deflection of 50 mm diameter, grid No. 4 and No. 2 voltage 2000 V and screen current 0.5 μ A)

0.4 mm

Capacitances

D_1 to all other electrodes except D_1'	4.7 pF
D_1' to all other electrodes except D_1	4.7 pF
D_2 to all other electrodes except D_2'	5.5 pF
D_2' to all other electrodes except D_2	5.5 pF
Between D_1 and D_1'	1.9 pF
Between D_2 and D_2'	2.5 pF
Between D_1D_1' and D_2D_2'	0.2 pF
Grid No. 1 to all other electrodes	4.6 pF
Grid No. 1 to all deflection plates	0.15 pF
Cathode to all other electrodes	6 pF
Cathode to all deflection plates	0.6 pF

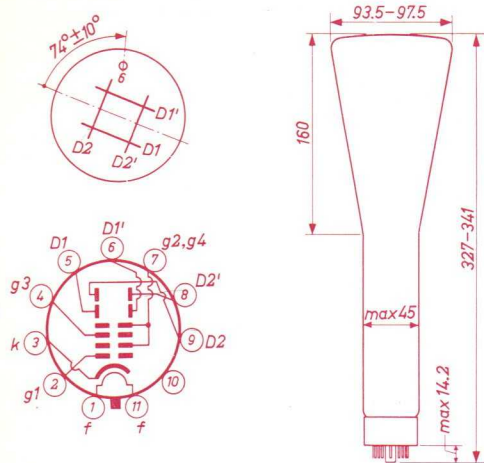

*) It is recommended to earth the accelerator. Grid No. 4 performs the accelerator function, but since grids No. 4 and No. 2 are interconnected internally, they are collectively referred to as accelerator.

Typical operation

Accelerator (grids No. 4 and No. 2) voltage	2000 V *
Focusing electrode (grid No. 5) voltage	400-720 V
Focusing electrode (grid No. 5) current	from -15 to +10 μ A
Grid No. 1 bias for visual cut-off	-45 to -100 V
Deflection sensitivity plates D_1D_1'	0.52-0.38 mm/V
Deflection sensitivity plates D_2D_2'	0.24-0.30 mm/V

Ratings

Accelerator (grids No. 4 and No. 2) voltage, maximum
2500 V

Accelerator (grids No. 4 and No. 2) dissipation, maximum
4 W

Focusing electrode (grid No. 5) voltage, maximum

Grid No. 1 voltage positive-bias value, maximum
negative-bias value, maximum

Peak voltage between deflection plates D_1D_1' , maximum

Peak voltage between deflection plates D_2D_2' , maximum

Screen dissipation, maximum

Voltage between heater and cathode, maximum

Resistance in any deflection plate circuit, maximum

Grid No. 1 circuit resistance, maximum

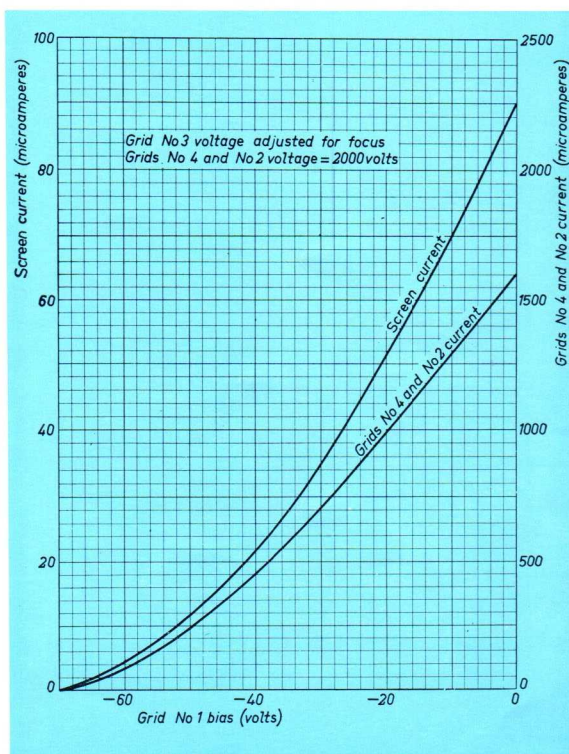

1000 V
0 V
150 V
450 V
450 V
5 mW/cm ²
125 V
5 M Ω
1.5 M Ω

DB10-6**DG10-6****DP10-6****DR10-6****Heating**

Indirect by A.C. or D.C.

Heater voltage 6.5 V

Heater current 0.5 A

Focusing

Electrostatic

Deflection

Double electrostatic

Deflection plates D_1D_1' and D_2D_2' for symmetrical drive**Line width**

With post-deflection accelerator (grid No. 5) voltage 2000 V

0.4 mm

With post-deflection accelerator (grid No. 5) voltage 4000 V

0.5 mm

(measured with concentric circular deflection of 50 mm diameter, grids No. 4 and No. 2 voltage 2000 V and screen current 0.5 μ A)**Capacitances** D_1 to all other electrodes except D_1' 4.7 pF D_1' to all other electrodes except D_1 4.7 pF D_2 to all other electrodes except D_2' 5.5 pF D_2' to all other electrodes except D_2 5.5 pFBetween D_1 and D_1' 1.9 pFBetween D_2 and D_2' 2.5 pFBetween D_1D_1' and D_2D_2' 0.2 pF

Grid No. 1 to all other electrodes 4.6 pF

Grid No. 1 to all deflection plates 0.15 pF

Cathode to all other electrodes 6 pF

Cathode to all deflection plates 0.6 pF

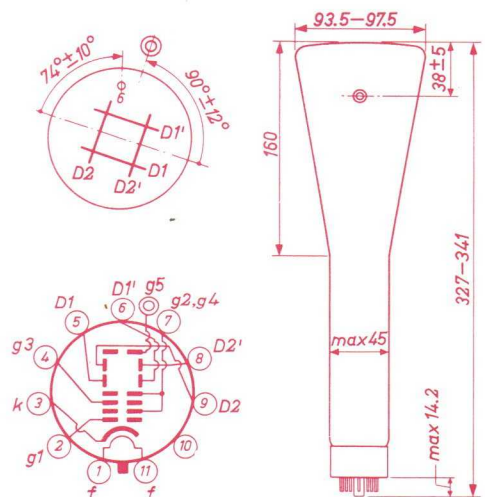
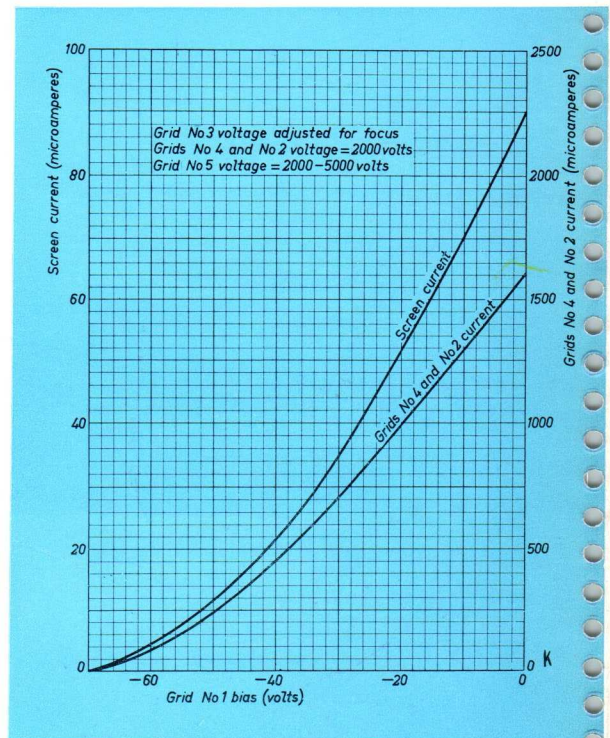

Typical operation

	without post acceleration	with post acceleration
Post-deflection accelerator (grid No. 5) voltage	2000	4000 V
Pre-deflection accelerator (grids No. 4 and No. 2) voltage	2000	2000 V*)
Focusing electrode (grid No. 3) voltage	400-720	400-720 V
Focusing electrode (grid No. 3) current	-15 to +10	-15 to +10 μ A
Grid No. 1 bias for visual cut-off, between	-45 and -100	-45 and -100 V
Deflection sensitivity plates D_1D_1'	0.52-0.58	0.25-0.51 mm/V
Deflection sensitivity plates D_2D_2'	0.24-0.50	0.19-0.25 mm/V

Ratings

Post-deflection accelerator (grid No. 5) voltage, maximum 5000 V



Pre-deflection accelerator (grids No. 4 and No. 2) voltage, maximum	2500 V
Ratio between post-deflection accelerator (grid No. 5) voltage and pre-deflection accelerator (grids No. 4 and No. 2) voltage, maximum	2.2
Pre-deflection accelerator (grids No. 4 and No. 2) dissipation, maximum	4 W
Focusing electrode (grid No. 3) voltage, maximum	1000 V
Grid No. 1 voltage positive-bias value, maximum	0 V
negative-bias value, maximum	150 V
Peak voltage between deflection plates D_1D_1' , maximum	450 V
Peak voltage between deflection plates D_2D_2' , maximum	450 V
Screen dissipation, maximum	3 mW/cm ²
Voltage between heater and cathode, maximum	125 V
Resistance in any deflection plate circuit, maximum	5 M Ω
Grid No. 1 circuit resistance, maximum	1.5 M Ω

*) It is recommended to earth the pre-deflection accelerator. Grid No. 4 performs the pre-deflection accelerator function, but since grids No. 4 and No. 2 are interconnected internally, they are collectively referred to as pre-deflection accelerator.

DB13-2

DG13-2

DP13-2

DR13-2

Heating

Indirect by A.C. or D.C.

Heater voltage 6.5 V

Heater current 0.5 A

Focusing

Electrostatic

Deflection

Double electrostatic

Deflection plates D_1D_1' and D_2D_2' for symmetrical drive

Line width

With post-deflection accelerator (grid No. 5) voltage 2000 V

With post-deflection accelerator (grid No. 5) voltage 4000 V

(measured with concentric circular deflection of 50 mm diameter, grids No. 4 and No. 2 voltage 2000 V and screen current 0.5 μ A)

0.4 mm

0.5 mm

Capacitances

D_1 to all other electrodes except D_1'

4.7 pF

D_1' to all other electrodes except D_1

4.7 pF

D_2 to all other electrodes except D_2'

5.5 pF

D_2' to all other electrodes except D_2

5.5 pF

Between D_1 and D_1'

1.9 pF

Between D_2 and D_2'

2.5 pF

Between D_1D_1' and D_2D_2'

0.2 pF

Grid No. 1 to all other electrodes

4.6 pF

Grid No. 1 to all deflection plates

0.15 pF

Cathode to all other electrodes

6 pF

Cathode to all deflection plates

0.35 pF



Typical operation

Respectively without and with post acceleration.

Post-deflection accelerator (grid No. 5) voltage 2000 resp. 4000 V

Pre-deflection accelerator (grids No. 4 and No. 2) voltage 2000 resp. 2000 V*)

Focusing electrode (grid No. 3) voltage 400-720 resp. 400-720 V

Focusing electrode (grid No. 3) current -15 to +10 resp. -15 to +10 μA

Grid No. 1 bias for visual cut-off, between -45 and -100 resp. -45 and -100 V

Deflection sensitivity plates D_1D_1' 0.43-0.51 resp. 0.34-0.42 mm/V

Deflection sensitivity plates D_2D_2' 0.37-0.45 resp. 0.29-0.37 mm/V

Ratings

Post-deflection accelerator

(grid No. 5) voltage, maximum 5000 V

Pre-deflection accelerator

(grids No. 4 and No. 2) voltage, maximum 2500 V

Ratio between post-deflection

accelerator (grid No. 5) voltage and pre-deflection accelerator (grids No. 4 and No. 2) voltage, maximum 2.2

Pre-deflection accelerator

(grids No. 4 and No. 2) dissipation, maximum 4 W

Focusing electrode (grid No. 3)

voltage, maximum 1000 V

Grid No. 1 voltage

positive-bias value, maximum 0 V

negative-bias value, maximum 150 V

Peak voltage between deflection plates D_1D_1' , max. 450 V

Peak voltage between deflection plates D_2D_2' , max. 450 V

Screen dissipation, maximum 3 mW/cm²

Voltage between heater and cathode, maximum 125 V

Resistance in any deflection plate circuit, maximum 5 M Ω

Grid No. 1 circuit resistance, maximum 1.5 M Ω

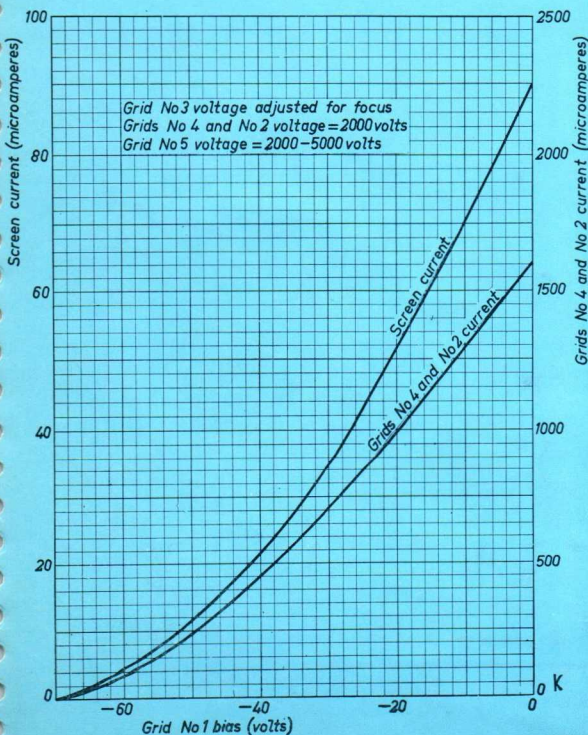
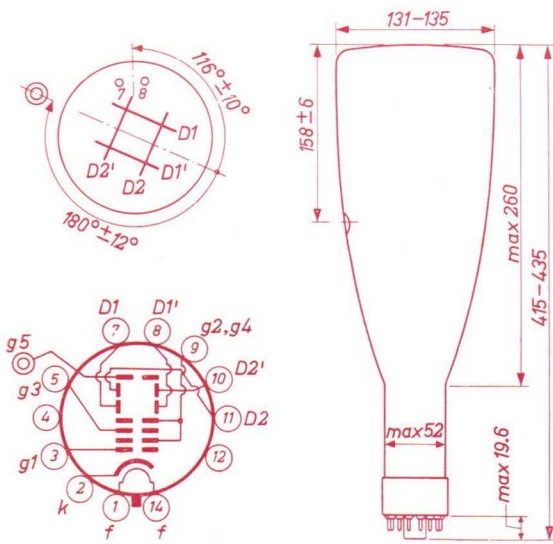

*) It is recommended to earth the pre-deflection accelerator. Grid No. 4 performs the pre-deflection accelerator function, but since grids No. 4 and No. 2 are interconnected internally, they are collectively referred to as pre-deflection accelerator.

TUBE HOLDERS

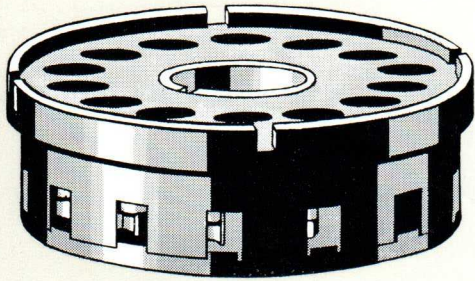

Tube holder for the cathode-ray tubes
DB 13-2, DG 13-2, DP 13-2, DR 13-2.
Type 40212.

Tube holder for the cathode-ray tubes
DB 10-2, DG 10-2, DP 10-2, DR 10-2,
DB 10-6, DG 10-6, DP 10-6, DR 10-6.
Type 5911/20.

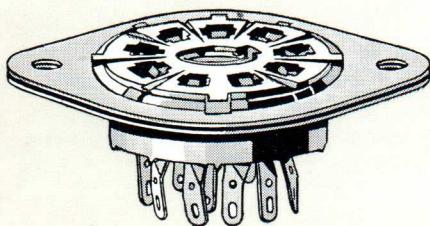
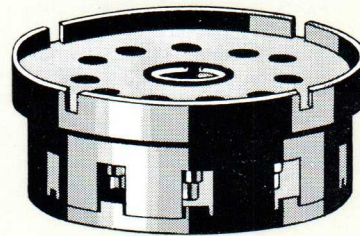

Tube holder for the cathode-ray tubes
DB 4-2, DG 4-2, DP 4-2, DB 7-5, DG 7-5,
DP 7-5, DR 7-5, DB 7-6, DG 7-6, DP 7-6,
DR 7-6. Type 5914/20.

Type 40212 should read: Type 5914/20
Type 5914/20 should read: Type 40212

